

**IMPORTANT NOTE****Curtain Walling**

Please note both CWCT and NHBC consider all storey height glazing to be a curtain wall and therefore should be designed as such. Curtain walling cannot be treated in the same way as window and door installations.

The following are requirements in undertaking a Curtain Walling project:

- Full elevation drawings must be produced. These drawings should clearly indicate all perimeter interface details typically showing water / vapour barriers, pressings / trims, fixing brackets / fixings along with any fire stopping that may be required. This is not an exhaustive list as other details may be required to suit specific projects.
- All bracketry and fixings should be backed up by calculations from a structural engineer to confirm suitability and meet site requirements. Also, profiles need to be identified to suit site conditions. These factors include screen sizes, fixing positions, glass weight, barrier loadings & wind loadings.
- It may be a requirement to include for on-site water testing and pull out testing. NHBC would require certification to the CWCT weather test where glazing may span a floor as opposed to a BS6375-1 window / door weather test.

Please also consider acoustic, thermal and structural performance when specifying curtain wall configuration and components.

**IMPORTANT NOTE:**

It would be expected that one or more members of installation teams have been certified by the Systems supplier to demonstrate competence and understanding of the system being installed.

**THIS PAGE IS INTENTIONALLY LEFT BLANK**

## Main Index

<b>MC</b> <b>Index</b>	<b>Index</b> .....	A01 - A04
<b>A</b> <b>MC</b>	<b>Profiles</b>	
	Specification Pages.....	A05 - A08
	Technical Information.....	A09 - A14
	Scale Profile Drawings.....	A15 - A26
<b>B</b> <b>MC</b>	<b>Accessories</b>	
	Photos & Drawings.....	B03 - B16
<b>C</b> <b>MC</b>	<b>Sections</b>	
	Scale Elevations.....	C01 - C34
<b>D</b> <b>MC</b>	<b>Statics</b> .....	D01 - D12
<b>E</b> <b>MC</b>	<b>Construction Drawings</b>	
	NHBC Notice.....	E03
	Bracket requirements.....	E04
	Horizontal Deductions.....	E05
	Stick Build Mullion Preparation - ACMC650.....	E06
	Stick Build Transom Preparation.....	E07
	Stick Build Assembly - ACMC650 Spring Pin.....	E08 - E09
	Ladder Build Assembly - Shear Block.....	E10
	Drainage & Pressure Equalisation.....	E11
	Reinforcing Sleeves.....	E12
	Splice Joints.....	E13
	Transom / Mullion Sealing.....	E14
	Sleeves.....	E15
	Mullion on Transom Preparation.....	E16
	Mullion on Transom Assembly.....	E17
	Raked Head.....	E18
	Glazing Details.....	E19

**Updates**

DATE	PAGE	DESCRIPTION
26/01/2021	All Sections	<p>Removed old version of reinforcing sleeves;                      -MC644, MC646, MC648, MC649, MC900, ACMC684,                      ACMC686, ACMC688, ACMC689</p> <p>Removed Facetted on plan sections &amp; Accessories;                      -MC670, MC671, MC672, MC675, MC676, MC677, SR014</p> <p>Added New Shear Block for MC604;                      -ACMC607</p> <p>Added Raked Head;                      -ACMC6052, ACMC6053, ACMC6054, ACMC6056, ACMC6058,                      ACMC6059, ACMC693, ACMC646, ACMC647</p> <p>Added;                      -MC117, MC118, MC165, MC166</p>



## Specification

### GENERAL DESCRIPTION

MC600 is a stick build curtain wall system suitable for low to high rise installations in commercial buildings.

Designed for quick and easy workshop preparation and on-site installation, MC600 is a cost effective system which offers a high quality finish.

### PROFILE SPECIFICATION

The sections are constructed of aluminium alloy extrusion to BS EN 755-9 and BS EN 12020, extruded from 6060 T6 alloy.

The aluminium alloy extrusion is pre-treated and finished either:-

- a) Anodised to BS 3987: 1987, grade AA25 to a natural self colour.
- b) Polyester powder organic coating to BS EN 12206-1.

### GENERAL MANUFACTURING

After careful inspection of the extrusions, all visible areas shall be taped using our recommended protective tape to help protect against any scratches.

Sections are cut with accurate 90° ends using Tungsten Carbide Tipped Saw Blades, operating at approximately 3000 rpm. The isolators, MC601 can be inserted into the mullions/transoms prior to cutting.

The mullions are marked and drilled using the recommended drill jig ACMC695.

Transoms are drilled using recommended drill jig ACMC691 in preparation for the fixing bracket ACMC600 which is secured into position using ACET060 stainless steel self tapping screws.

On polyester powder coated finishes, great care should be taken to avoid getting gap sealer on visible surfaces and should be removed as soon as possible with a clean cloth.

Care should be exercised when using products not supplied by Smart Systems Ltd as no responsibility can be accepted.

## Specification

### DRAINAGE

As with all dry glazed systems, the system must be adequately drained and ventilated. Refer to drainage details in manual, if in doubt ask the Technical Department.

### WORKSHOP MANUFACTURING INFORMATION

After careful inspection of the extrusions, all visible areas shall be taped using our recommended protective tape to help protect against any scratches.

Sections are cut with accurate 90° ends using Tungsten Carbide Tipped Saw Blades, operating at approximately 3000 rpm. The isolator MC601 can be inserted into the mullions/transoms prior to cutting.

The mullions are marked to show the centre line of the transoms and are drilled with a 4mm dia. drill bit for the ACMC600 brackets and a 6.5mm dia. drill bit for the ACMC650 anti-rotation spring pin using the recommended drill jig ACMC695.

Transoms are drilled with a 3mm dia. drill bit using recommended drill jig ACMC691 in preparation for the fixing bracket ACMC600 which is secured into position using ACET060 stainless steel self tapping screws. The ACMC650 anti-rotation spring pin is slid into the position and secured by tightening the grub screw.

**IMPORTANT NOTE:** Maximum weight on ACMC600 / ACMC605 is 500kg.

All gaskets and transom end pads may be fitted in the workshop to save time on site.

### ON SITE ASSEMBLY INFORMATION

After mullions are secured into position, the transoms are inserted between the vertical members until the ACMC650 anti-rotation spring pin engages into the predrilled hole. Transom end pads should be sealed using ACSIL05. Care should be taken to ensure the transom end pads are not dislodged at this point. The transom is secured into position via the ACMC600 brackets using PUA028 stainless steel self tapping screws.

Moulded corners shall be fitted between the gaskets and sealed using ACMX09830 EPDM adhesive. ACMC630 glazing supports shall be positioned in preparation for the double glazed units.

### GLAZING

Double glazed units shall be positioned on plastic packers on ACMC630 glazing supports with equal distance on all sides.

Units are secured in position using DK154 with ACDK066 or MC655 fixing (not compatible with ACDK066) held in place by ACMC610 or ACMC612 Hex Head Self Tapping Fixing Screw taking care not to exceed torque of 4Nm at the recommended speed of 1500-1800rpm. Stitch plates may be used to secure the units temporarily until all units are in position. Pressure plates shall be fitted at the top first, working downwards to help avoid uneven fixings.

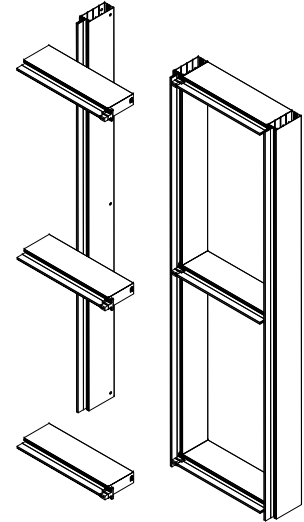
The cover caps are clipped in position using a rubber mallet taking care to strike the corners only to avoid denting the section. Vertical cover caps are fitted first followed by the horizontal caps.

## Specification

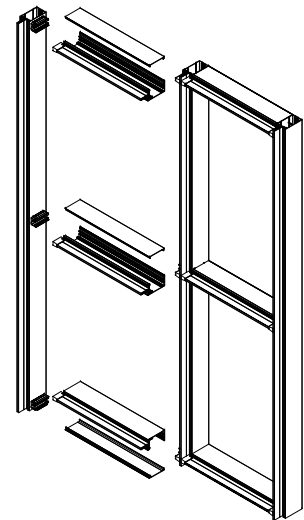
### Construction Options

The MC600 Curtain Walling System may be installed as a stick, ladder frame or as a screwed system.

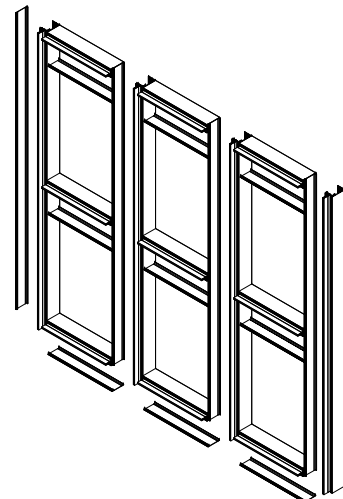
Stick build is a fast method of fabrication and installation. The Curtain Wall is taken to a site in stick form and the mullions are first to be assembled - usually from the centre outwards. The transoms are then fitted from the front of the Curtain Wall. Spring Pins (ACMC650) fixed to the transoms, locate in pre-drilled holes in the mullions and the transoms are then secured using a face mounted bracket - ACMC600



Where ladder frames are used, shear blocks (ACMC602 / ACMC603) are fixed to the mullions in the factory and 'ladders' built and taken to the site ready assembled. The ladders are connected together on site by locating open sided transoms (MC615 / MC617) over the shear blocks, fixing them from the front through the transom face, into the shear block screwports. A clip plate (MC650 / MC651) is then pushed into place to close the transom.



A final method of construction is to use two part mullions / transoms (MC615 / MC650 and/or MC617 / MC651) and fix using screws through the mullions into screwports within the transoms.



## Specification

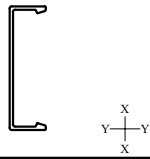
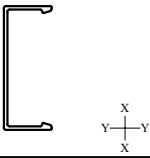
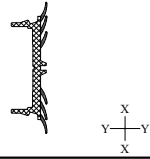
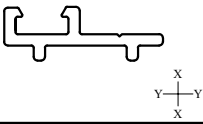
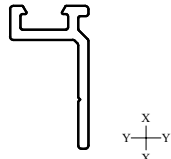
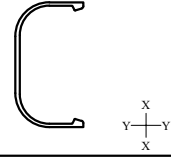
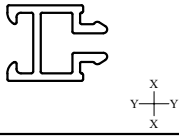
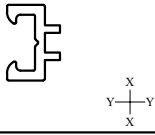
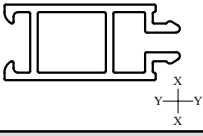
### **MC600 Weather Performance (CWCT - Standard for Systemised Building Envelopes)**

BS EN 12152 Air Permeability:	Class 4 600Pa
BS EN 12154 Watertightness:	Class R7 600Pa
BS EN 13116 Resistance to Wind Load:	Class 2400 2400Pa

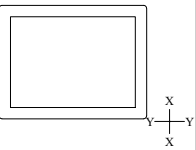
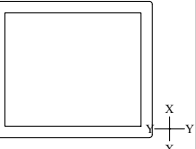
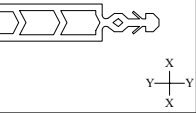
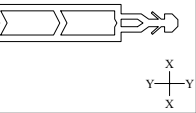
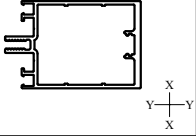
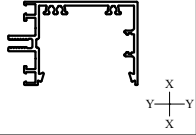
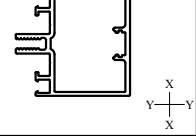
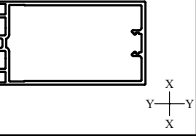
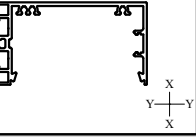
### **MC600 U Values**

Contact Technical Department

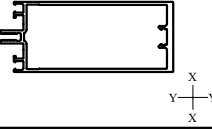
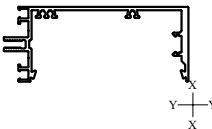
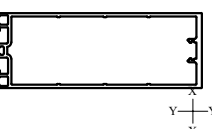
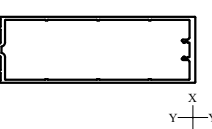
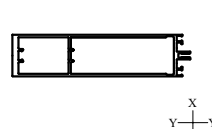
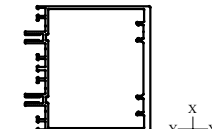
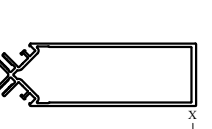
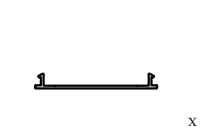

**PROFILES : TECHNICAL INFORMATION**

Number	Picture	Page	Perim. (mm)	Mec. (mm)	$ix(cm^4)$ $wx(cm^3)$	$iy(cm^4)$ $wy(cm^3)$	Length (m)	Pack pr.	MF	SA	KL	HP	M
DK052		A22	170	96	-	-	7 6.5	1	✓	✓	✓	✓	
DK053		A22	190	98	-	-	7 6.5	1	✓	✓	✓	✓	
DK154		A26	171	-	-	-	7	1	✓				
ETC090		A20	68	-	-	-	5	1	✓	✓	✓	✓	
ETC091		A20	75	-	-	-	5	1	✓	✓	✓	✓	
MC050		A22	206	102	-	-	7	1	✓	✓	✓	✓	
MC116		A26	85	34.5	-	-	7	1	✓	✓	✓	✓	
MC117		A26	48	18	-	-	7	1	✓	✓	✓	✓	
MC118		A26	105	49	-	-	7	1	✓	✓	✓	✓	
								A = Outside B = Inside	MF = Mill Finish SA = Silver Anodised KL = Basic Colour HP = Special Colour M = Dual Colour				



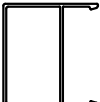









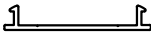



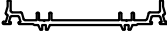

PROFILES : TECHNICAL INFORMATION

Number	Picture	Page	Perim. (mm)	Mec. (mm)	ix(cm <sup>4</sup> ) wx(cm <sup>3</sup> )	iy(cm <sup>4</sup> ) wy(cm <sup>3</sup> )	Length (m)	Pack pr.	MF	SA	KL	HP	M	
MC165		A25	91	-	-	-	7	1	✓	✓	✓	✓		
MC166		A25	103	-	-	-	7	1	✓	✓	✓	✓		
MC601		A26	-	-	-	-	7	1	✓					
MC602		A26	-	-	-	-	7	1	✓					
MC603		A15	396	205	71.6 — 14.9	31.7 — 11.5	7	1	✓	✓	✓	✓		
MC604		A16	-	-	-	-	7	1	✓	✓	✓	✓		
MC612		A15	346	155	23.5 — 7.2	20.7 — 7.5	7	1	✓	✓	✓	✓		
MC614		A16	444	255	120.6 — 21.7	35.2 — 12.8	7	1	✓	✓	✓	✓		
MC615		A17	657	157	116.9 — 20.7	22.7 — 12.3	6.5	1	✓	✓	✓	✓		
									A = Outside B = Inside		MF = Mill Finish SA = Silver Anodised KL = Basic Colour HP = Special Colour M = Dual Colour			

**PROFILES : TECHNICAL INFORMATION**

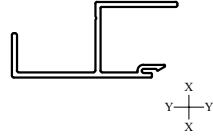
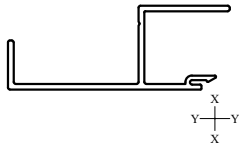
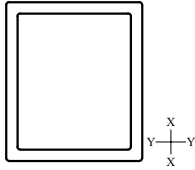
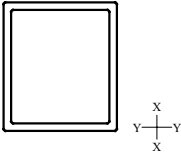
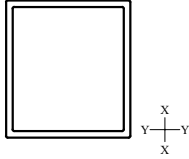
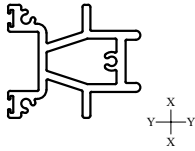
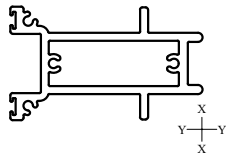
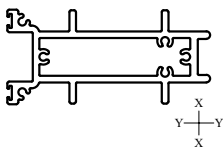
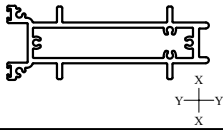
Number	Picture	Page	Perim. (mm)	Mec. (mm)	ix(cm <sup>4</sup> ) wx(cm <sup>3</sup> )	iy(cm <sup>4</sup> ) wy(cm <sup>3</sup> )	Length (m)	Pack pr.	MF	SA	KL	HP	M	
MC616		A18	496	305	250 — 33.2	45 — 16.4	7	1	✓	✓	✓	✓		
MC617		A18	705	181	232.2 — 32.2	25.8 — 14.7	6.5	1	✓	✓	✓	✓		
MC618		A19	546	355	380.4 — 44.6	59.5 — 21.6	7	1	✓	✓	✓	✓		
MC619		A19	586	395	575 — 57	68.5 — 24.9	7	1	✓	✓	✓	✓		
MC620		A17	695	505	1453.2 — 110.42	114.3 — 41.6	7	1	✓	✓	✓	✓		
MC621		A21	692	312	297 — 45.9	247.9 — 45.1	7	1	✓	✓	✓	✓		
MC625		A20	625	353	521.3 — 57.4	69.9 — 25.4	7	1	✓	✓	✓	✓		
MC650		A17	221	94	-	-	6.5	1	✓	✓	✓	✓		
MC651		A18	271	119	-	-	6.5	1	✓	✓	✓	✓		
									A = Outside B = Inside		MF = Mill Finish SA = Silver Anodised KL = Basic Colour HP = Special Colour M = Dual Colour			

**PROFILES : TECHNICAL INFORMATION**

Number	Picture	Page	Perim. (mm)	Mec. (mm)	ix(cm <sup>4</sup> ) wx(cm <sup>3</sup> )	iy(cm <sup>4</sup> ) wy(cm <sup>3</sup> )	Length (m)	Pack pr.	MF	SA	KL	HP	M	
MC652	 	A22	188	97	-	-	7	1	✓	✓	✓	✓		
MC653	 	A22	247	154	-	-	7	1	✓	✓	✓	✓		
MC654	 	A22	206	105	-	-	7	1	✓	✓	✓	✓		
MC655	 	A26	212	-	-	-	7	1	✓					
MC655H PREPPED FOR HORIZONTAL	 	A23	212	-	-	-	7	1	✓					
MC655V PREPPED FOR VERTICAL	 	A24	212	-	-	-	7	1	✓					
MC656	 	A16	171	69	-	-	6.5	1	✓	✓	✓	✓		
MC657	 	A21	298	152.9	-	-	7	1	✓	✓	✓	✓		
MC658	 	A21	-	-	-	-	7	1	✓					
									A = Outside B = Inside		MF = Mill Finish SA = Silver Anodised KL = Basic Colour HP = Special Colour M = Dual Colour			



**PROFILES : TECHNICAL INFORMATION**

Number	Picture	Page	Perim. (mm)	Mec. (mm)	ix(cm <sup>4</sup> ) wx(cm <sup>3</sup> )	iy(cm <sup>4</sup> ) wy(cm <sup>3</sup> )	Length (m)	Pack pr.	MF	SA	KL	HP	M
MC663		A25	209	42	-	-	6.5	1	✓	✓	✓	✓	
MC664		A25	229	52	-	-	6.5	1	✓	✓	✓	✓	
MC665		A25	103	103	-	-	7	1	✓	✓	✓	✓	
MC666		A25	127	127	-	-	7	1	✓	✓	✓	✓	
MC667		A25	-	-	-	-	7	1	✓	✓	✓	✓	
MC693		A15	336	-	23.1 — 7.6	13.8 — 5.5	6	1	✓				
MC694		A16	375	-	69.7 — 15.8	17 — 6.8	6	1	✓				
MC696		A18	462	-	142.9 — 37.7	22.3 — 8.9	6	1	✓				
MC698		A19	507	-	258.9 — 37.7	23.9 — 9.8	6	1	✓				
									A = Outside B = Inside		MF = Mill Finish SA = Silver Anodised KL = Basic Colour HP = Special Colour M = Dual Colour		

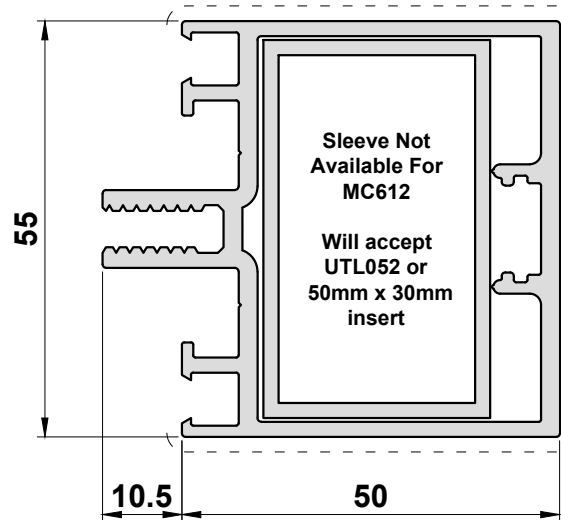


Primary Visible Side

Secondary Visible Side

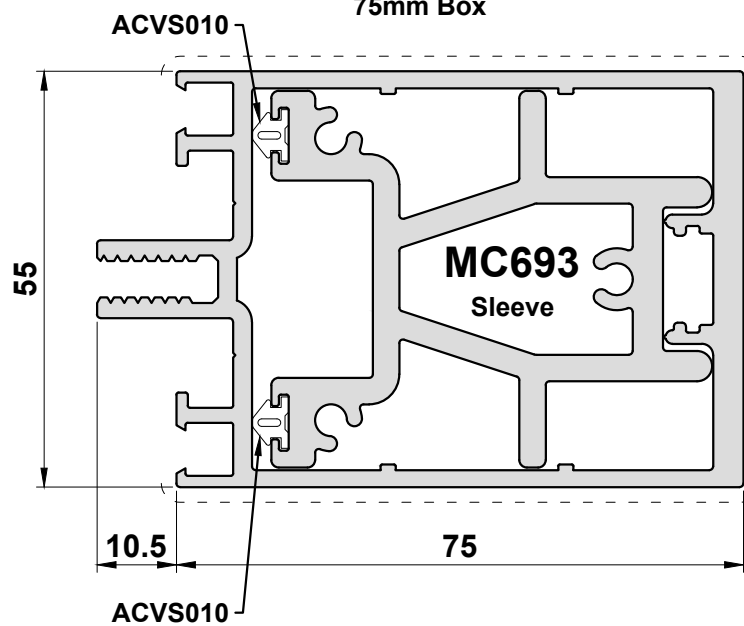
**MC612**

50mm Box



**MC603**

75mm Box



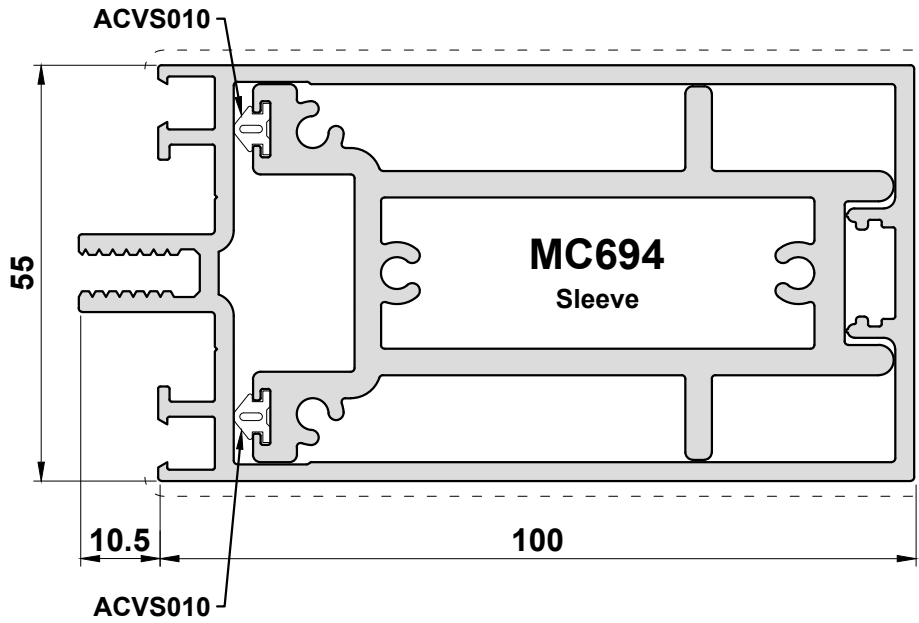
Scale 1:1

Primary Visible Side

Secondary Visible Side

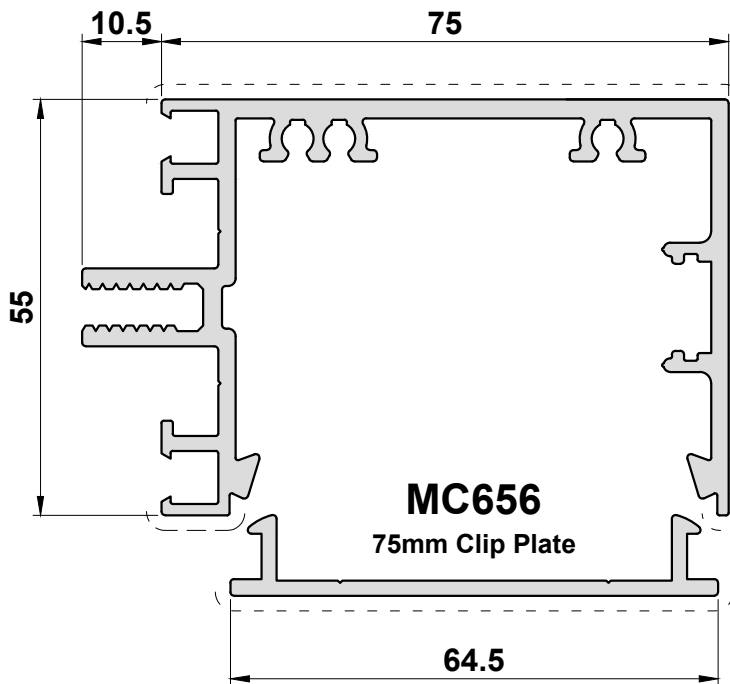
**MC614**

100mm Box



**MC604**

75mm Open Box

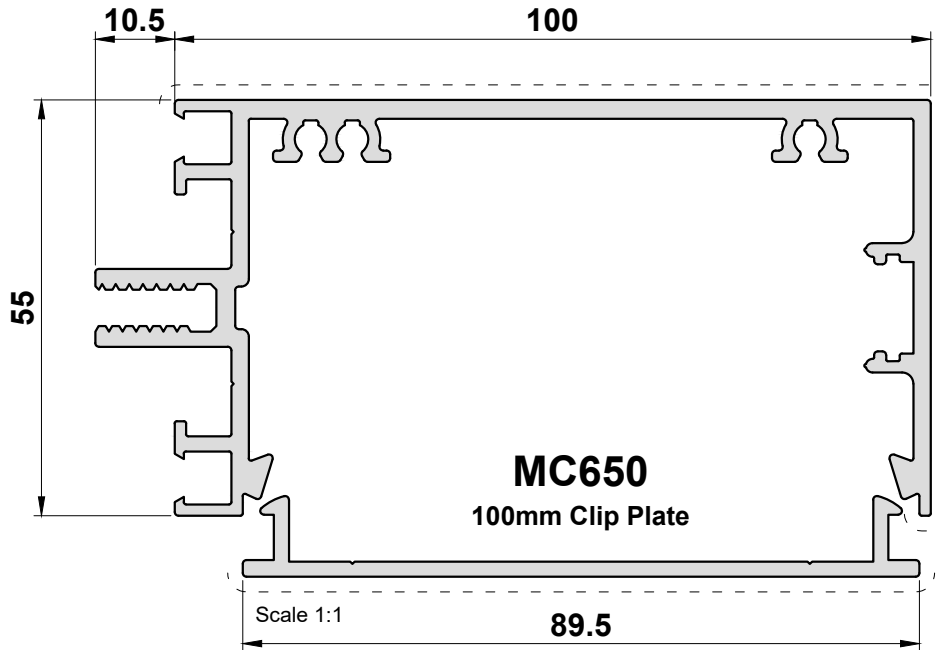


Scale 1:1

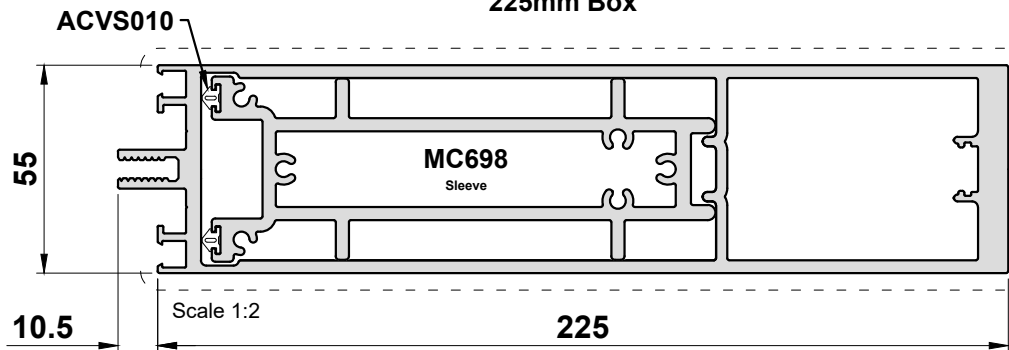
Primary Visible Side

Secondary Visible Side

**MC615**  
100mm Open Box



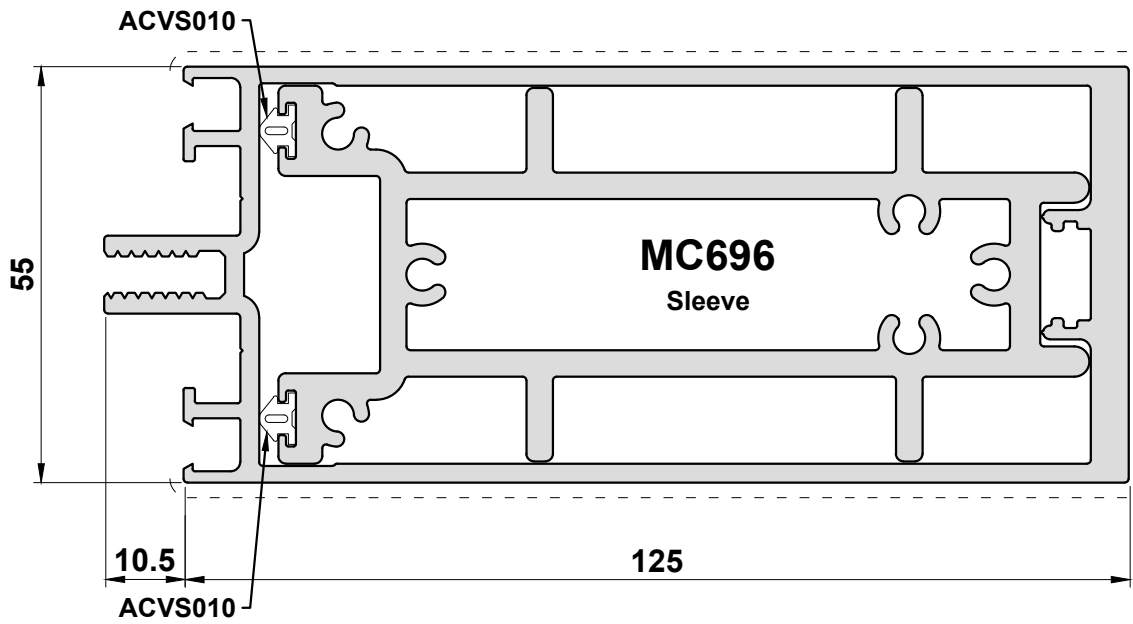
**MC620**  
225mm Box



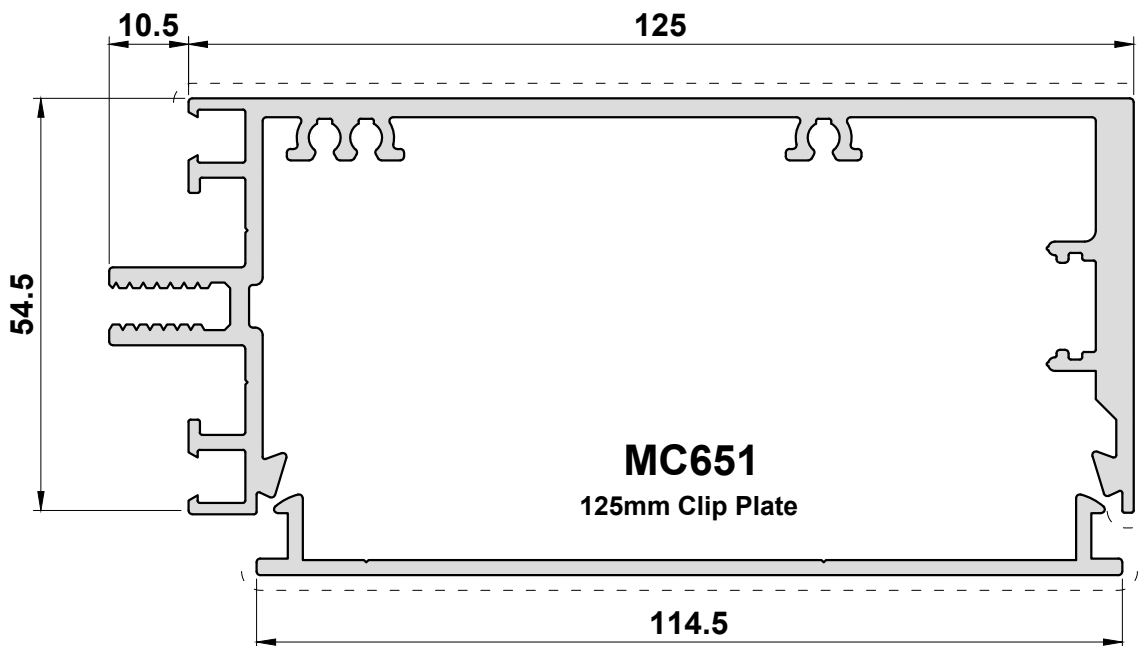
Primary Visible Side

Secondary Visible Side

**MC616**  
125mm Box



**MC617**  
125mm Open Box



Scale 1:1

Primary Visible Side

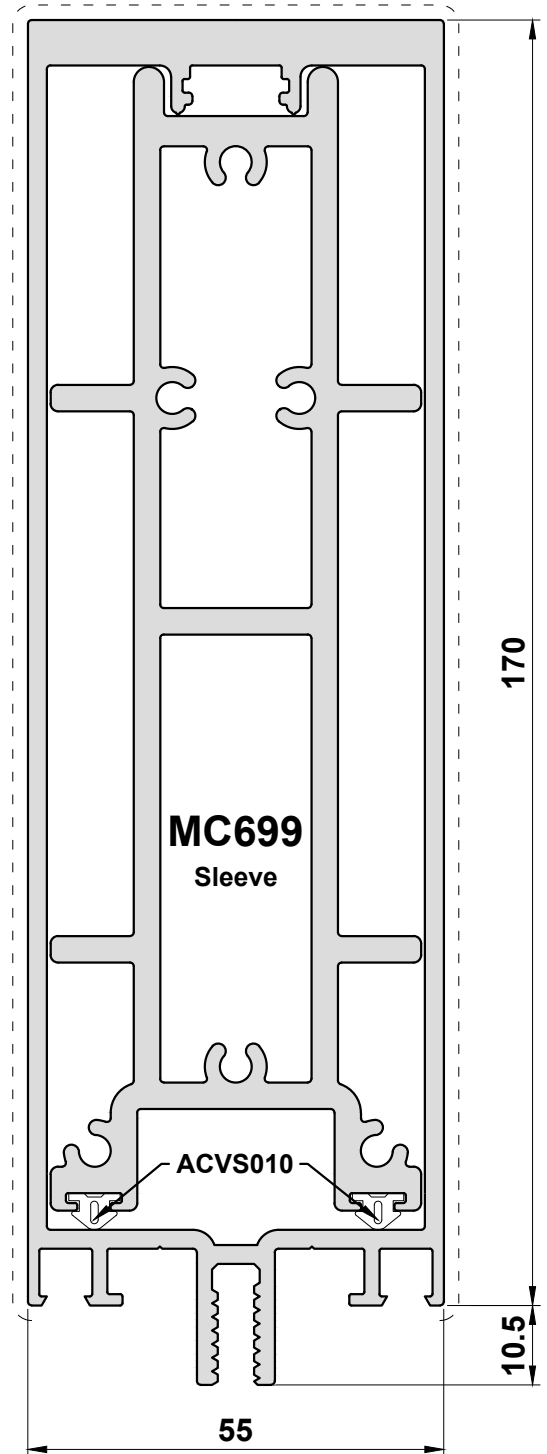
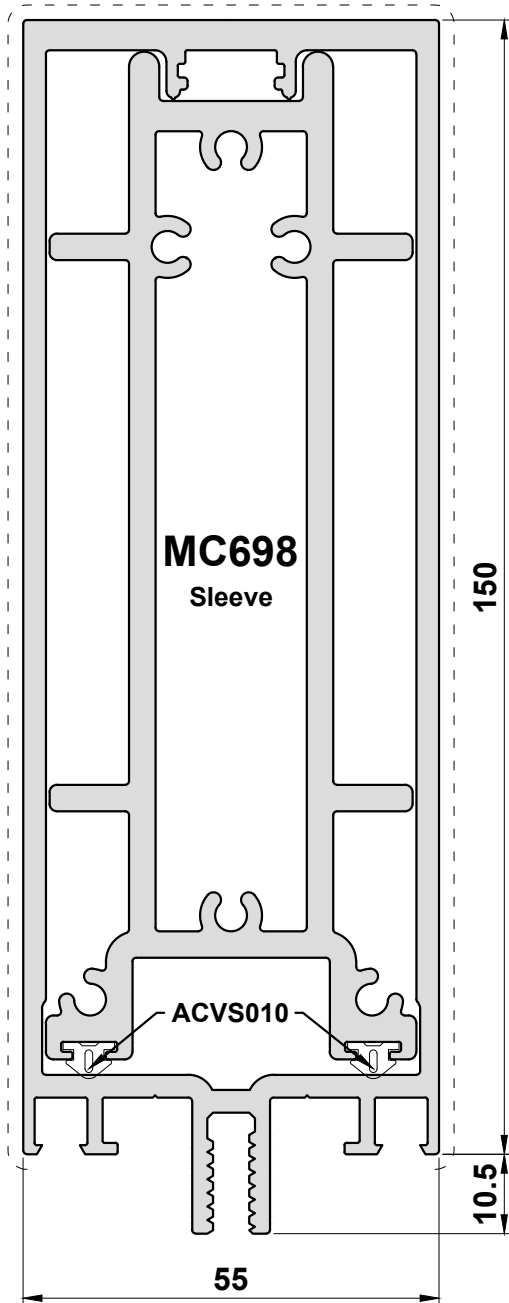
Secondary Visible Side

**MC618**

150mm Box

**MC619**

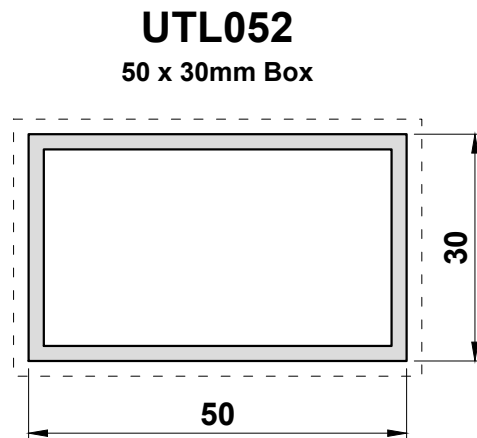
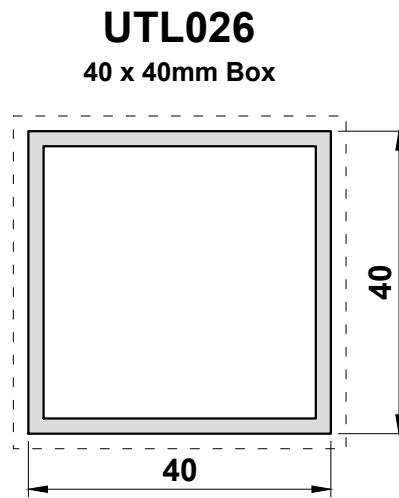
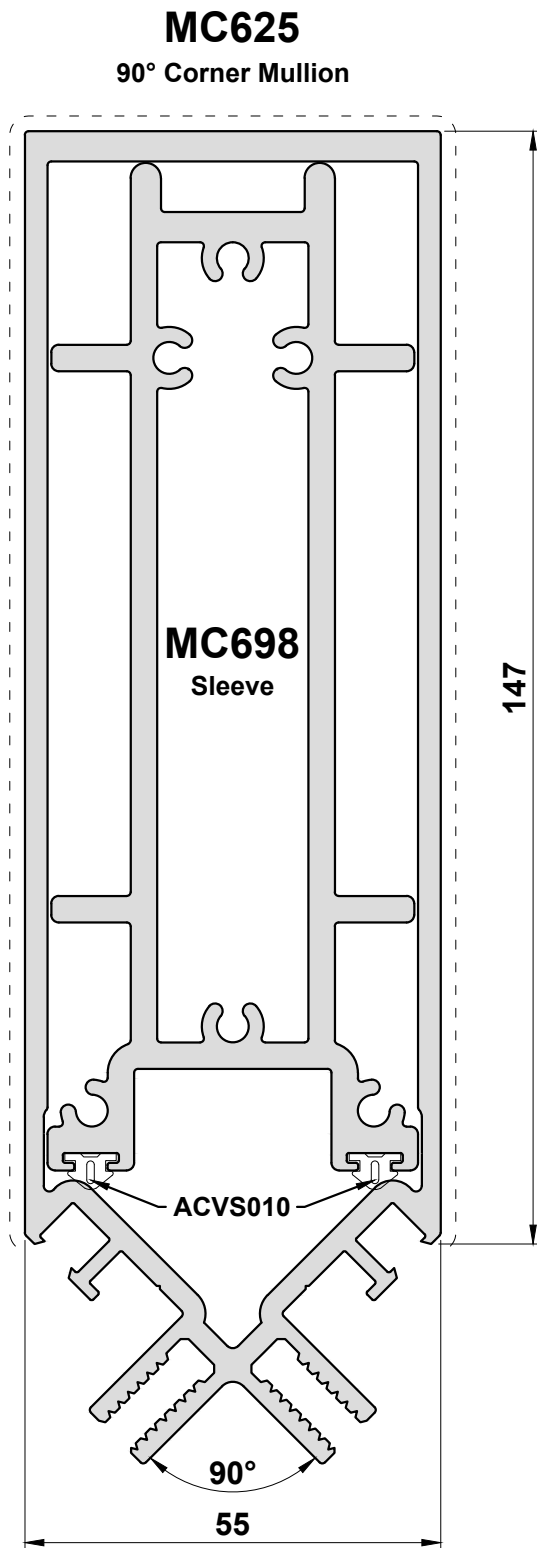
170mm Box



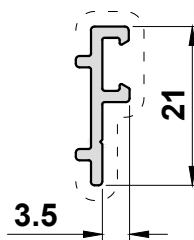
Scale 1:1

Primary Visible Side

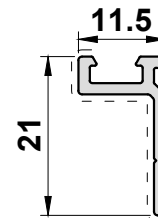
Secondary Visible Side



**ETC090**  
EPDM Carrier



**ETC091**  
EPDM Carrier



Scale 1:1

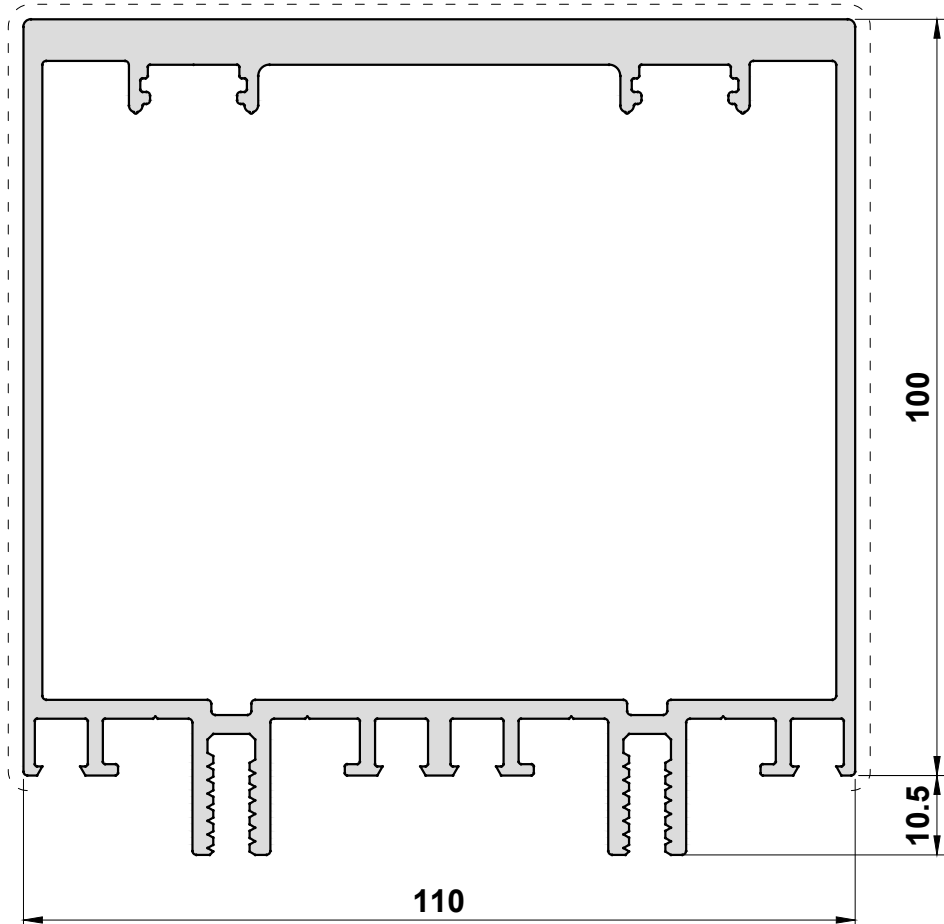


Primary Visible Side

Secondary Visible Side

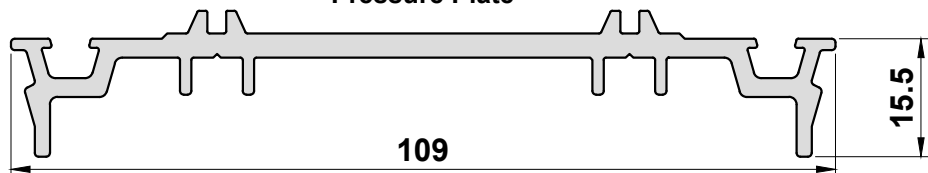
**MC621**

100mm x 110mm Transom



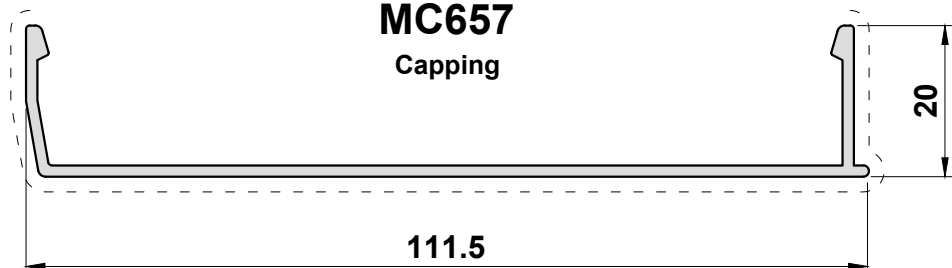
**MC658**

Pressure Plate



**MC657**

Capping

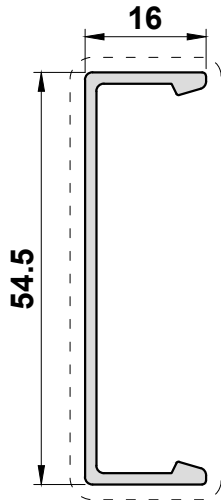


Scale 1:1

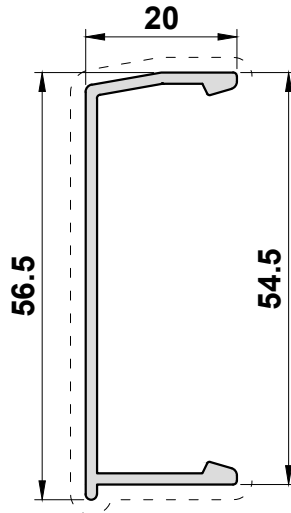
Primary Visible Side

Secondary Visible Side

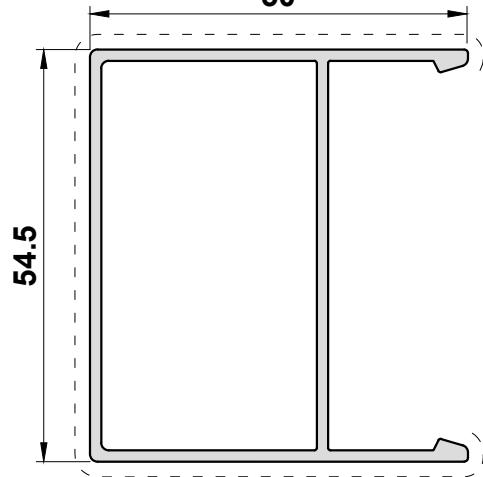
**DK052**  
Horizontal Capping



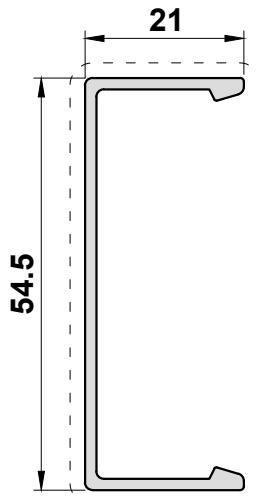
**MC652**  
Horizontal Capping  
with Drip



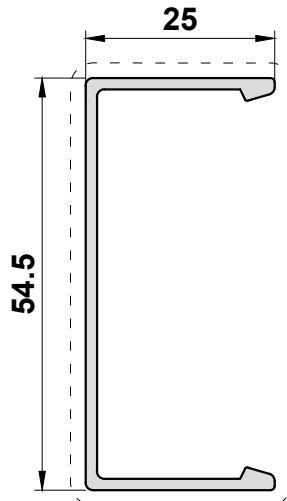
**MC653**  
50mm Vertical  
Capping



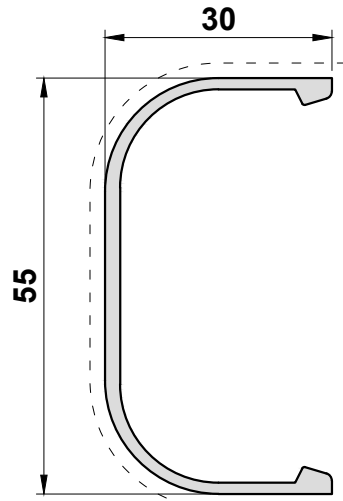
**DK053**  
Vertical Capping



**MC654**  
Vertical Capping



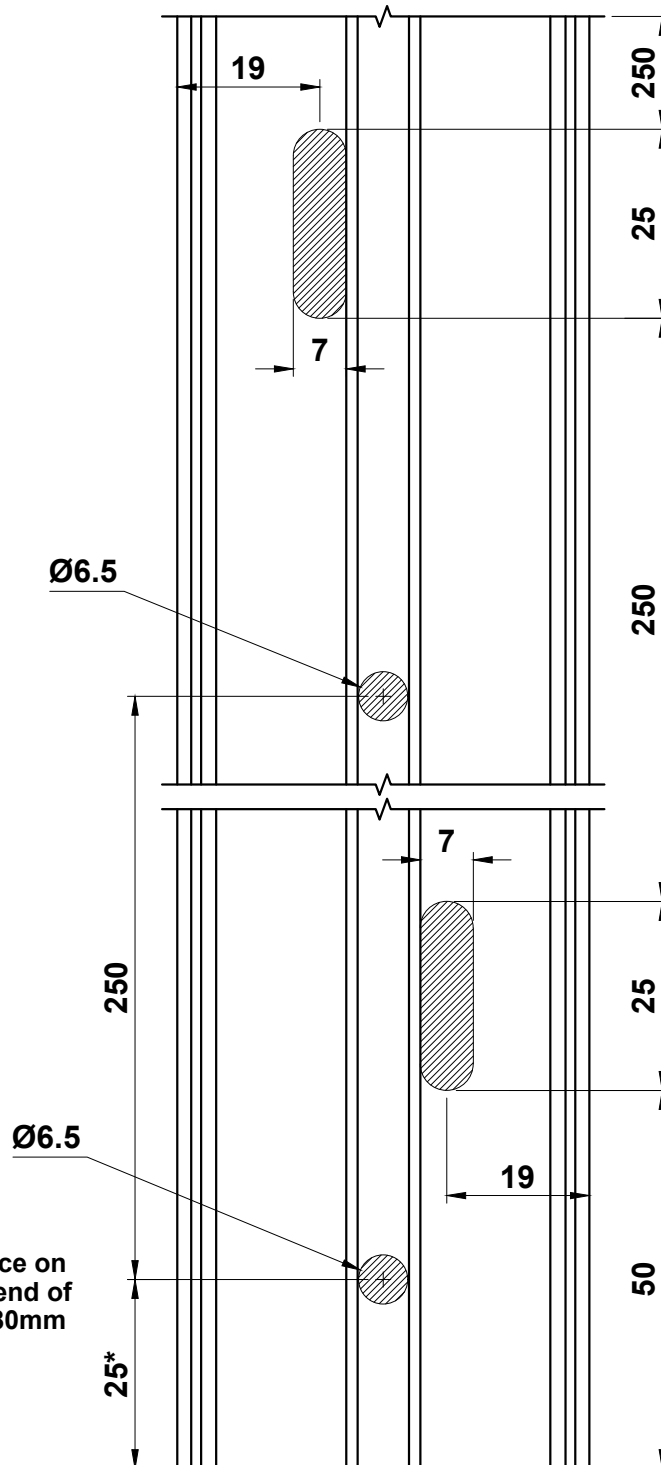
**MC050**  
Vertical Capping



Scale 1:1

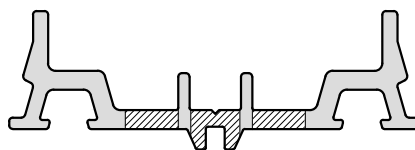
Primary Visible Side

Secondary Visible Side



\*Maximum distance on fixing holes from end of pressure plate = 80mm

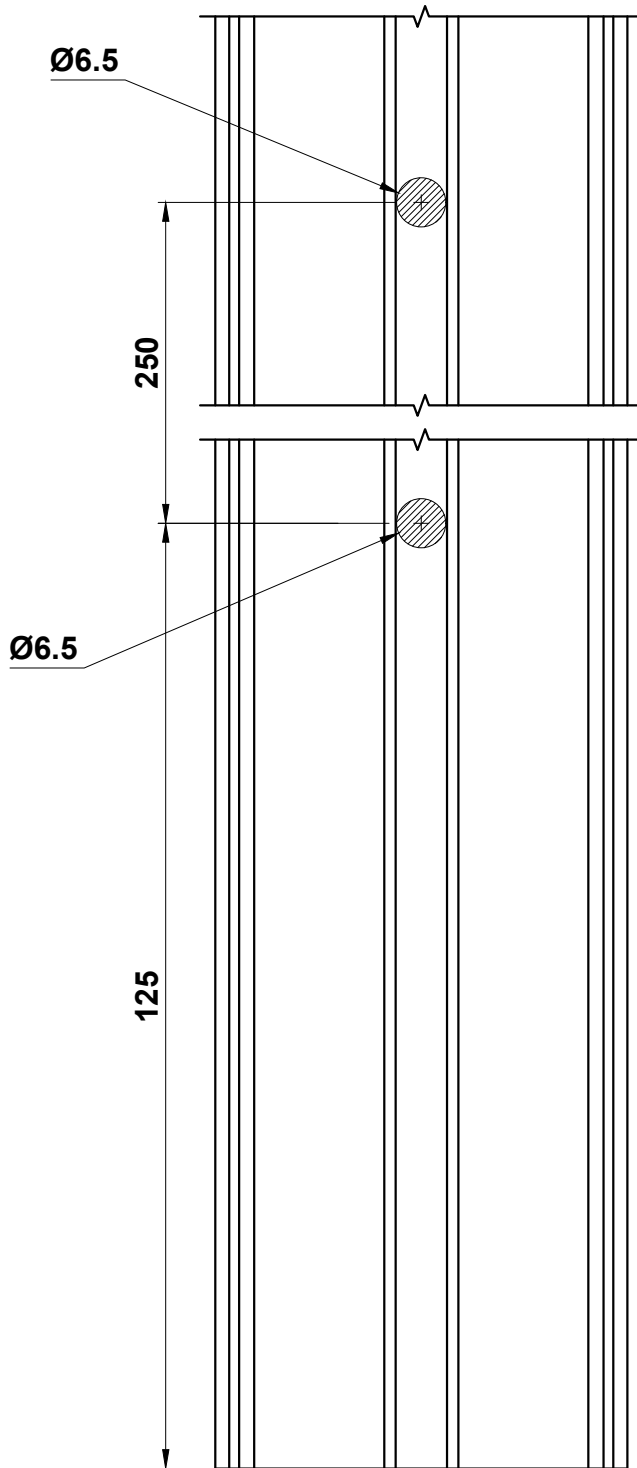
**MC655H**  
Pre-Drilled Horizontal  
Pressure Plate



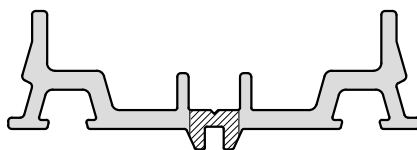
Scale 1:1

Primary Visible Side

Secondary Visible Side



**MC655V**  
Pre-Drilled Vertical  
Pressure Plate



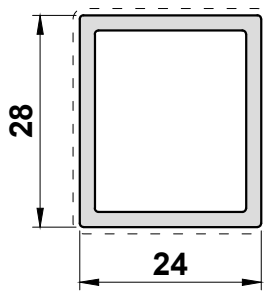
Scale 1:1

Primary Visible Side

Secondary Visible Side

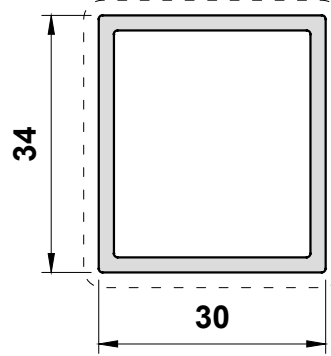
**MC665**

Infill



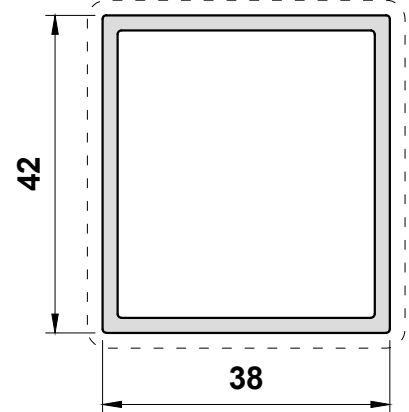
**MC666**

Infill



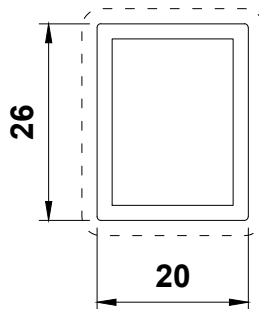
**MC667**

Infill



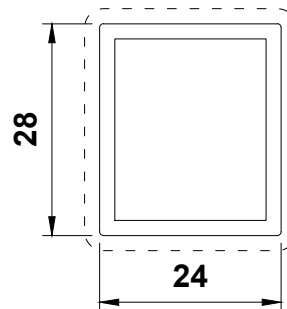
**MC165**

Infill



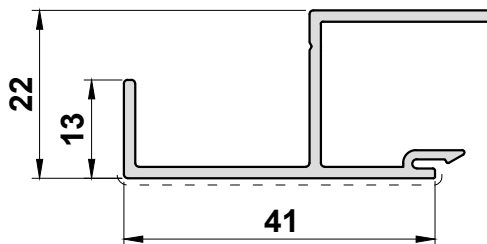
**MC166**

Infill



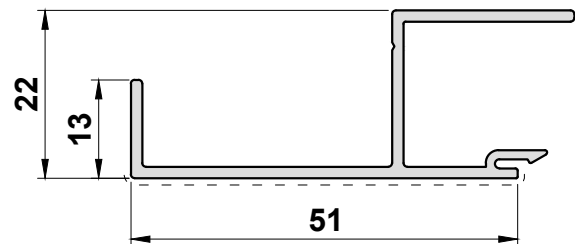
**MC663**

Infill



**MC664**

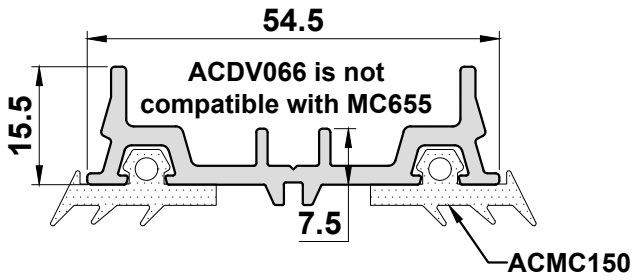
Infill



Scale 1:1

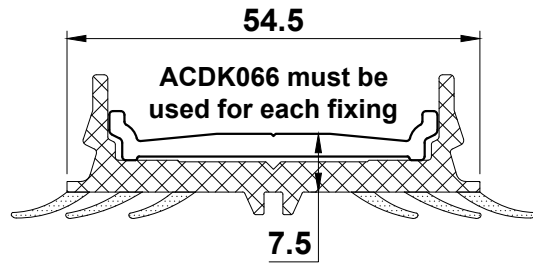
**MC655**

Aluminium Pressure Plate



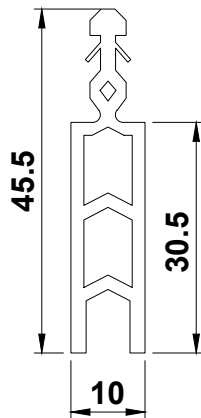
**DK154**

Pressure Plate



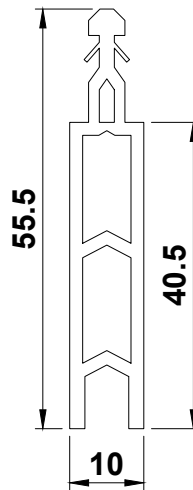
**MC601**

Insulator

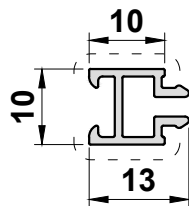


**MC602**

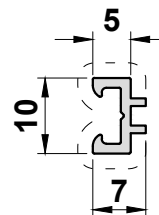
Insulator



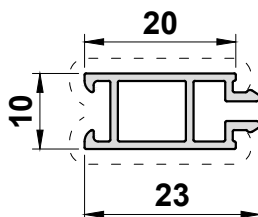
**MC116**  
Rebate Adaptor



**MC117**  
Rebate Adaptor



**MC118**  
Rebate Adaptor



**Section B**

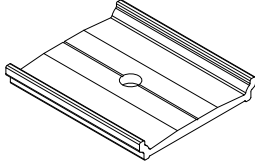
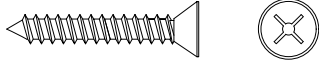
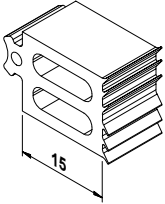
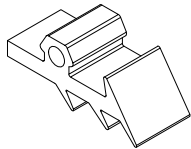
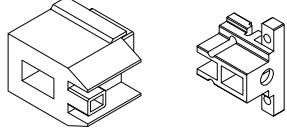

**Accessories**

**Photos & Drawings**

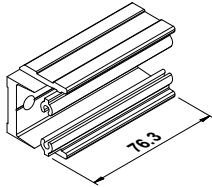
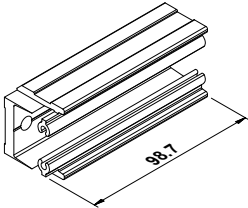
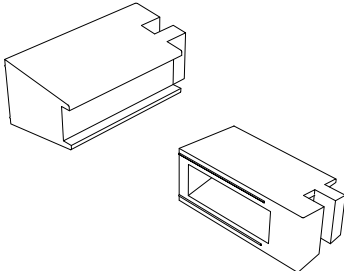
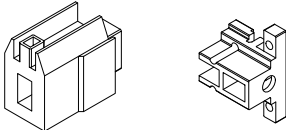
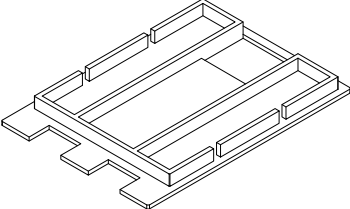


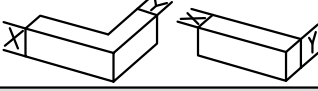
THIS PAGE IS INTENTIONALLY LEFT BLANK



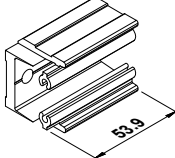

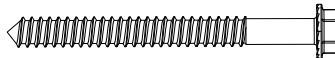
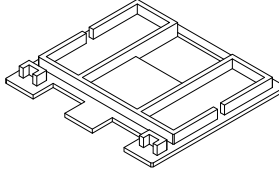
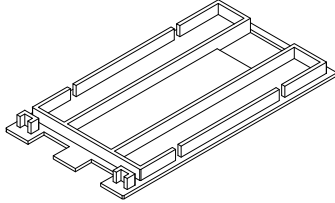


**ACCESSORIES : PHOTOS & DRAWINGS**

Image	Part Code	Pack	Unit	Application	Colour	
	<b>ACDK066</b>  Fixing Plate for DK154 only  <b>DO NOT USE WITH MC655</b>	1	each	<b>DK154</b>	MF	✓
					SA	
					KL	
					HP	
					SSC	
					SMC	
					W	
					Z	
					PC	
						<b>ACET060</b>  No.7 x 1" CSK S/S Self Tapper
SA						
KL						
HP						
SSC						
SMC						
W						
Z						
PC						
	<b>ACMC115</b>  Gasket for 24mm Glazing	100	m	<b>MC612</b> <b>MC614</b> <b>MC615</b> <b>MC616</b> <b>MC617</b> <b>MC618</b> <b>MC619</b>		
					SA	
					KL	
					HP	
					SSC	
					SMC	
					W	
					Z	✓
					PC	
						<b>ACMC150</b>  Gasket for MC655
SA						
KL						
HP						
SSC						
SMC						
W						
Z	✓					
PC						
	<b>ACMC600</b>  Transom Bracket Packed with ACMC601	10	pack	<b>MC603</b> <b>MC612</b> <b>MC614</b> <b>MC616</b> <b>MC618</b> <b>MC619</b> <b>MC620</b> <b>MC621</b> <b>MC625</b>	MF	✓
					SA	
					KL	
					HP	
					SSC	
					SMC	
					W	
					Z	
					PC	
					 <p>T-BARS ACVG65=2.5mm ACVG66=3.0mm ACVL150=4.0mm</p> <p>Screw (Grub)</p>	MF = Mill Finish SA = Silver Anodised KL = Basic Colour HP = Special Colour SSC = Smooth Satin Chrome SMC = Smokey Chrome PC = Polished Chrome

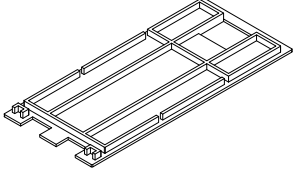
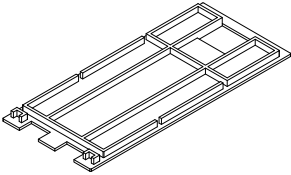
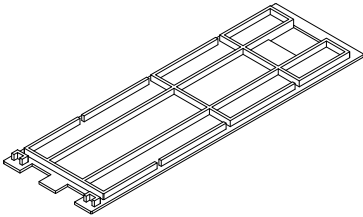
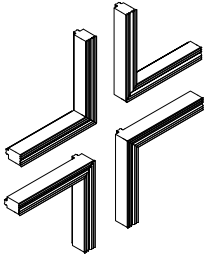
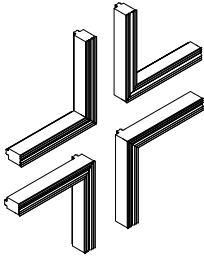


**ACCESSORIES : PHOTOS & DRAWINGS**

Image	Part Code	Pack	Unit	Application	Colour	
	<b>ACMC602</b>  Shear Block for MC615	20	pack	MC615	MF	✓
					SA	
					KL	
					HP	
					SSC	
					SMC	
					W	
					Z	
					PC	
	<b>ACMC603</b>  Shear Block for MC617	20	pack	MC617	MF	✓
					SA	
					KL	
					HP	
					SSC	
					SMC	
					W	
					Z	
					PC	
	<b>ACMC604</b>  Transom End Block	20	pack	<b>MC604</b> <b>MC615</b> <b>MC617</b>	MF	
					SA	
					KL	
					HP	
					SSC	
					SMC	
					W	
					Z	✓
					PC	
	<b>ACMC605</b>  Transom End Block for 34m - 42mm Glazing	20	pack	<b>MC603</b> <b>MC612</b> <b>MC614</b> <b>MC616</b> <b>MC618</b> <b>MC619</b> <b>MC620</b> <b>MC621</b> <b>MC625</b>	MF	
					SA	
					KL	
					HP	
					SSC	
					SMC	
					W	
					Z	✓
					PC	
	<b>ACMC606</b>  Transom End Pad for MC603	50	pack	MC603	MF	
					SA	
					KL	
					HP	
					SSC	
					SMC	
					W	
					Z	✓
					PC	
 T-BARS ACVG65=2.5mm ACVG66=3.0mm ACVL150=4.0mm	 Screw (Grub)	<b>MF</b> = Mill Finish <b>SA</b> = Silver Anodised <b>KL</b> = Basic Colour <b>HP</b> = Special Colour <b>SSC</b> = Smooth Satin Chrome <b>SMC</b> = Smokey Chrome <b>PC</b> = Polished Chrome	<b>W</b> = White <b>Z</b> = Black			

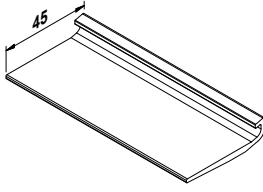
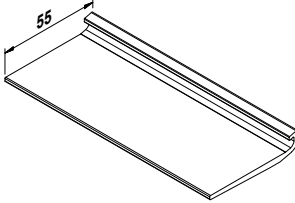
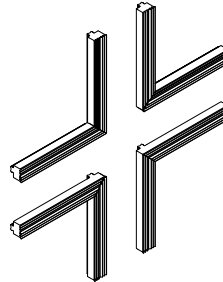
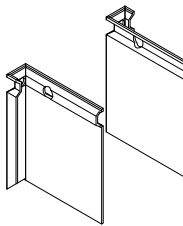
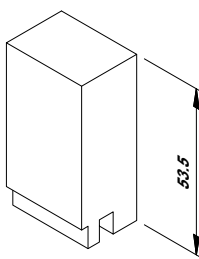


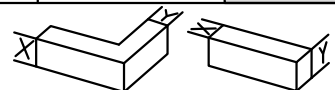
ACCESSORIES : PHOTOS & DRAWINGS

Image	Part Code	Pack	Unit	Application	Colour	
	<b>ACMC607</b>  Shear Block for MC604	<b>20</b>	pack	<b>MC604</b>	MF	✓
					SA	
					KL	
					HP	
					SSC	
					SMC	
					W	
					Z	
					PC	
						<b>ACMC610</b>  6.3mm x 53mm Hex Head Self Tapper
SA						
KL						
HP						
SSC						
SMC						
W						
Z						
PC						
	<b>ACMC612</b>  6.3mm x 63mm Hex Head Self Tapper	<b>100</b>	pack	<b>ACDK066</b> <b>DK154</b> <b>MC655</b>		
					SA	
					KL	
					HP	
					SSC	
					SMC	
					W	
					Z	
					PC	
						<b>ACMC613</b>  Transom End Pad for MC612
SA						
KL						
HP						
SSC						
SMC						
W						
Z	✓					
PC						
	<b>ACMC614</b>  Transom End Pad for MC614	<b>50</b>	pack	<b>MC614</b>		
					SA	
					KL	
					HP	
					SSC	
					SMC	
					W	
					Z	✓
					PC	
					 T-BARS ACVG65=2.5mm ACVG66=3.0mm ACVL150=4.0mm	 Screw (Grub)

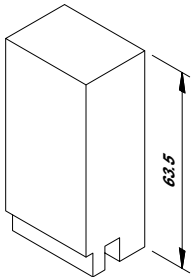
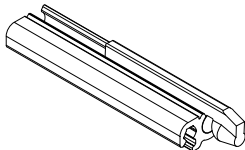
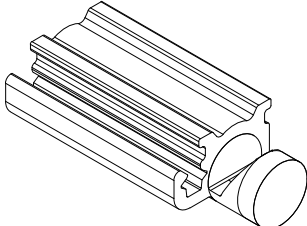
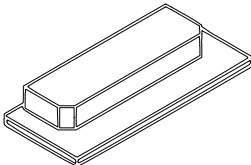
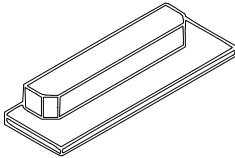


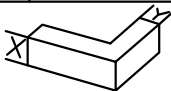
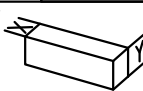
ACCESSORIES : PHOTOS & DRAWINGS

Image	Part Code	Pack	Unit	Application	Colour	
	<b>ACMC616</b>  Transom End Pad for MC616	<b>50</b>	pack	<b>MC616</b>	MF	
					SA	
					KL	
					HP	
					SSC	
					SMC	
					W	
					Z	✓
					PC	
						<b>ACMC618</b>  Transom End Pad for MC618
SA						
KL						
HP						
SSC						
SMC						
W						
Z	✓					
PC						
	<b>ACMC619</b>  Transom End Pad for MC619	<b>50</b>	pack	<b>MC619</b>		
					SA	
					KL	
					HP	
					SSC	
					SMC	
					W	
					Z	✓
					PC	
						<b>ACMC624</b>  Moulded Corner Gasket for 6mm, 24mm & 34mm Glazing
SA						
KL						
HP						
SSC						
SMC						
W						
Z						
PC						
	<b>ACMC628</b>  Moulded Corner Gasket for 10mm, 28mm & 38mm Glazing	<b>20</b>	pack	<b>ACSC212</b> <b>MC612</b> <b>MC614</b> <b>MC615</b> <b>MC616</b> <b>MC617</b> <b>MC618</b> <b>MC619</b>		
					SA	
					KL	
					HP	
					SSC	
					SMC	
					W	
					Z	
					PC	
					 T-BARS ACVG65=2.5mm ACVG66=3.0mm ACVL150=4.0mm	 Screw (Grub)

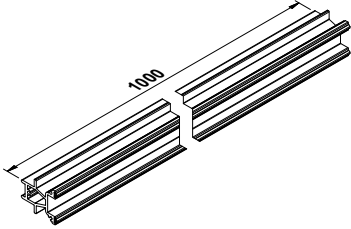
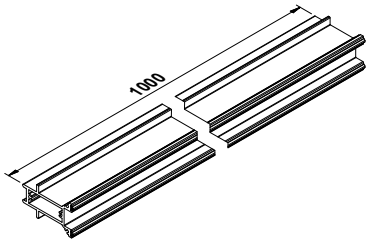
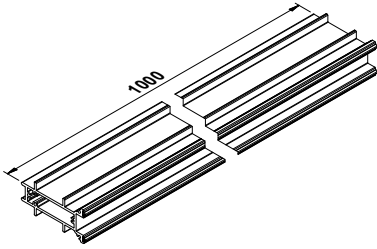
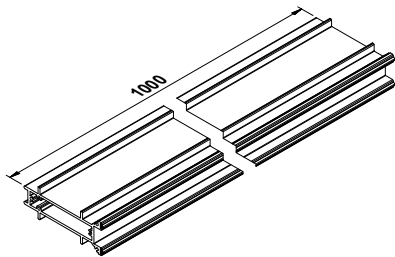
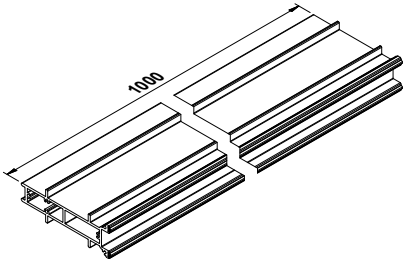

ACCESSORIES : PHOTOS & DRAWINGS

Image	Part Code	Pack	Unit	Application	Colour	
	<b>ACMC630</b>  Glazing Support (100mm)	20	pack	<b>MC612</b> <b>MC614</b> <b>MC615</b> <b>MC616</b> <b>MC617</b> <b>MC618</b> <b>MC619</b>	MF	✓
					SA	
					KL	
					HP	
					SSC	
					SMC	
					W	
					Z	
					PC	
	<b>ACMC631</b>  Glazing Support (100mm) for 34mm - 42mm	20	pack	<b>MC612</b> <b>MC614</b> <b>MC615</b> <b>MC616</b> <b>MC617</b> <b>MC618</b> <b>MC619</b>	MF	✓
					SA	
					KL	
					HP	
					SSC	
					SMC	
					W	
					Z	
					PC	
	<b>ACMC632</b>  Moulded Corner Gasket for 14mm, 32mm & 42mm Glazing	20	pack	<b>ACSC208</b> <b>MC612</b> <b>MC614</b> <b>MC615</b> <b>MC616</b> <b>MC617</b> <b>MC618</b> <b>MC619</b>	MF	
					SA	
					KL	
					HP	
					SSC	
					SMC	
					W	
					Z	✓
					PC	
	<b>ACMC644</b>  Cover Cap for Splice Joint	10	pack	<b>ACMC203</b> <b>MC612</b> <b>MC614</b> <b>MC615</b> <b>MC616</b> <b>MC617</b> <b>MC618</b> <b>MC619</b>	MF	✓
					SA	
					KL	
					HP	
					SSC	
					SMC	
					W	
					Z	
					PC	
	<b>ACMC646</b>  Foam End Block for Raked Heads For Glazing 6mm - 32mm	50	pack	<b>MC612</b> <b>MC614</b> <b>MC615</b> <b>MC616</b> <b>MC617</b> <b>MC618</b> <b>MC619</b>	MF	✓
					SA	
					KL	
					HP	
					SSC	
					SMC	
					W	
					Z	
					PC	
 	MF = Mill Finish SA = Silver Anodised KL = Basic Colour HP = Special Colour SSC = Smooth Satin Chrome SMC = Smokey Chrome PC = Polished Chrome	W = White Z = Black				

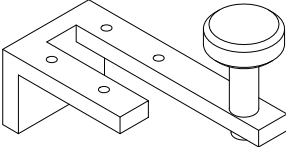
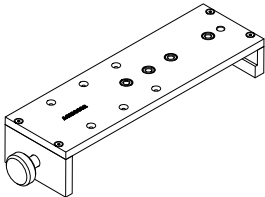
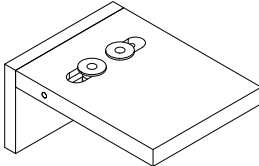
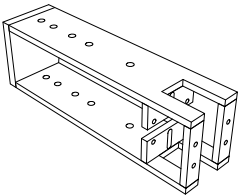
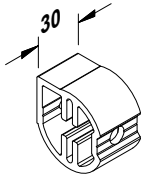

ACCESSORIES : PHOTOS & DRAWINGS

Image	Part Code	Pack	Unit	Application	Colour
	<b>ACMC647</b> Foam End Block for Raked Heads For Glazing 34mm - 42mm	50	pack	<b>MC612</b> <b>MC614</b> <b>MC615</b> <b>MC616</b> <b>MC617</b> <b>MC618</b> <b>MC619</b>	MF <input checked="" type="checkbox"/> SA <input type="checkbox"/> KL <input type="checkbox"/> HP <input type="checkbox"/> SSC <input type="checkbox"/> SMC <input type="checkbox"/> W <input type="checkbox"/> Z <input type="checkbox"/> PC <input type="checkbox"/>
	<b>ACMC650</b> Spring Pin With Hook	1	each	<b>MC612</b> <b>MC614</b> <b>MC615</b> <b>MC616</b> <b>MC617</b> <b>MC618</b> <b>MC619</b>	MF <input checked="" type="checkbox"/> SA <input type="checkbox"/> KL <input type="checkbox"/> HP <input type="checkbox"/> SSC <input type="checkbox"/> SMC <input type="checkbox"/> W <input type="checkbox"/> Z <input type="checkbox"/> PC <input type="checkbox"/>
	<b>ACMC651</b> Fixed Anti-Rotation Pin with Hook	1	each	<b>MC612</b> <b>MC614</b> <b>MC615</b> <b>MC616</b> <b>MC617</b> <b>MC618</b> <b>MC619</b>	MF <input checked="" type="checkbox"/> SA <input type="checkbox"/> KL <input type="checkbox"/> HP <input type="checkbox"/> SSC <input type="checkbox"/> SMC <input type="checkbox"/> W <input type="checkbox"/> Z <input type="checkbox"/> PC <input type="checkbox"/>
	<b>ACMC660</b> End Cap	50	pack	<b>DK053</b>	MF <input type="checkbox"/> SA <input type="checkbox"/> KL <input type="checkbox"/> HP <input type="checkbox"/> SSC <input type="checkbox"/> SMC <input type="checkbox"/> W <input type="checkbox"/> Z <input type="checkbox"/> PC <input type="checkbox"/>
	<b>ACMC661</b> End Cap	50	pack	<b>DK052</b>	MF <input type="checkbox"/> SA <input type="checkbox"/> KL <input type="checkbox"/> HP <input type="checkbox"/> SSC <input type="checkbox"/> SMC <input type="checkbox"/> W <input type="checkbox"/> Z <input type="checkbox"/> PC <input type="checkbox"/>
 T-BARS ACVG66=2.5mm ACVG66=3.0mm ACVL150=4.0mm	 Screw (Grub)	<b>MF</b> = Mill Finish <b>SA</b> = Silver Anodised <b>KL</b> = Basic Colour <b>HP</b> = Special Colour <b>SSC</b> = Smooth Satin Chrome <b>SMC</b> = Smokey Chrome <b>PC</b> = Polished Chrome	<b>W</b> = White <b>Z</b> = Black	 	

ACCESSORIES : PHOTOS & DRAWINGS

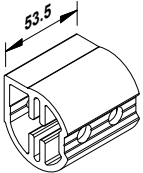
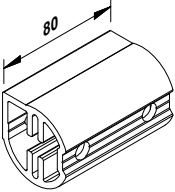
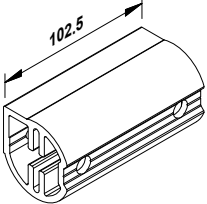
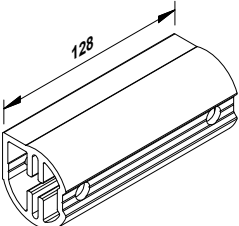
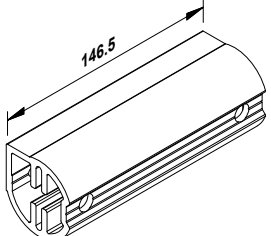



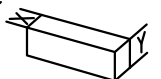
Image	Part Code	Pack	Unit	Application	Colour
	<b>ACMC663</b>  1000mm Sleeve for MC603 with ACVS010 inserts  Produced from MC693	1	each	<b>MC603</b>	MF
					SA
					KL
					HP
					SSC
					SMC
					W
					Z
					PC
					
SA					
KL					
HP					
SSC					
SMC					
W					
Z					
PC					
	<b>ACMC666</b>  1000mm Sleeve for MC616 with ACVS010 inserts  Produced from MC696	1	each	<b>MC616</b>	
					SA
					KL
					HP
					SSC
					SMC
					W
					Z
					PC
					
SA					
KL					
HP					
SSC					
SMC					
W					
Z					
PC					
	<b>ACMC669</b>  1000mm Sleeve for MC619 with ACVS010 inserts  Produced from MC699	1	each	<b>MC619</b>	
					SA
					KL
					HP
					SSC
					SMC
					W
					Z
					PC
					 T-BARS ACVG65=2.5mm ACVG66=3.0mm ACVL150=4.0mm

**ACCESSORIES : PHOTOS & DRAWINGS**

Image	Part Code	Pack	Unit	Application	Colour
	<b>ACMC691</b>  <b>Transom Drill Jig</b> Dual Purpose: -Transom Brackets -Shear Blocks	1	each	<b>MC612</b> <b>MC614</b> <b>MC616</b> <b>MC618</b> <b>MC619</b>	MF
					SA
					KL
					HP
					SSC
					SMC
					W
					Z
					PC
					
SA					
KL					
HP					
SSC					
SMC					
W					
Z					
PC					
	<b>ACMC693</b>  <b>Raked Head Drill Jig</b>	1	each	<b>MC614</b> <b>MC615</b> <b>MC616</b> <b>MC617</b> <b>MC618</b> <b>MC619</b>	
					SA
					KL
					HP
					SSC
					SMC
					W
					Z
					PC
					
SA					
KL					
HP					
SSC					
SMC					
W					
Z					
PC					
	<b>ACMC6052</b>  <b>Angle Bracket for MC612</b>	1	each	<b>MC612</b>	
					SA
					KL
					HP
					SSC
					SMC
					W
					Z
					PC
					 T-BARS ACVG85=2.5mm ACVG66=3.0mm ACVL150=4.0mm



**ACCESSORIES : PHOTOS & DRAWINGS**

Image	Part Code	Pack	Unit	Application	Colour
	<b>ACMC6053</b>  <b>Angle Bracket for MC603</b>	<b>1</b>	<b>each</b>	<b>MC603</b>	MF
					SA
					KL
					HP
					SSC
					SMC
					W
					Z
					PC
	<b>ACMC6054</b>  <b>Angle Bracket for MC614</b>	<b>1</b>	<b>each</b>	<b>MC614</b>	MF
					SA
					KL
					HP
					SSC
					SMC
					W
					Z
					PC
	<b>ACMC6056</b>  <b>Angle Bracket for MC616</b>	<b>1</b>	<b>each</b>	<b>MC616</b>	MF
					SA
					KL
					HP
					SSC
					SMC
					W
					Z
					PC
	<b>ACMC6058</b>  <b>Angle Bracket for MC618</b>	<b>1</b>	<b>each</b>	<b>MC618</b>	MF
					SA
					KL
					HP
					SSC
					SMC
					W
					Z
					PC
	<b>ACMC6059</b>  <b>Angle Bracket for MC619</b>	<b>1</b>	<b>each</b>	<b>MC619</b>	MF
					SA
					KL
					HP
					SSC
					SMC
					W
					Z
					PC
 <small>T-BARS ACVG66=2.5mm ACVG66=3.0mm ACVL150=4.0mm</small>	 <small>Screw (Grub)</small>	<b>MF = Mill Finish</b> <b>SA = Silver Anodised</b> <b>KL = Basic Colour</b> <b>HP = Special Colour</b> <b>SSC = Smooth Satin Chrome</b> <b>SMC = Smokey Chrome</b> <b>PC = Polished Chrome</b>	<b>W = White</b> <b>Z = Black</b>	 	

ACCESSORIES : PHOTOS & DRAWINGS

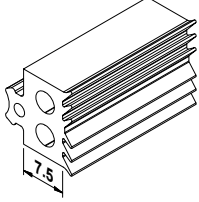
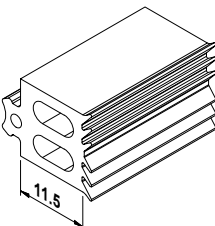
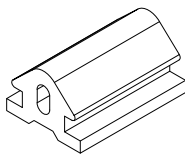
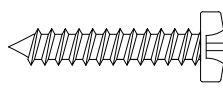

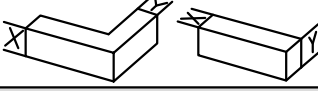
Image	Part Code	Pack	Unit	Application	Colour
	<b>ACSC208</b> Gasket for 32mm Glazing	100	m	<b>MC612</b> <b>MC614</b> <b>MC615</b> <b>MC616</b> <b>MC617</b> <b>MC618</b> <b>MC619</b>	MF SA KL HP SSC SMC W Z ✓ PC
	<b>ACSC212</b> Gasket for 28mm Glazing	100	m	<b>MC612</b> <b>MC614</b> <b>MC615</b> <b>MC616</b> <b>MC617</b> <b>MC618</b> <b>MC619</b>	MF SA KL HP SSC SMC W Z PC
	<b>ACVS010</b> Spacer for Inserts	7.3	m	<b>MC693</b> <b>MC694</b> <b>MC696</b> <b>MC698</b> <b>MC699</b>	MF SA KL HP SSC SMC W Z PC
	<b>PUA028</b> No.10 x 1" Pan Head Self Tapper	100	pack	<b>ACMC600</b>	MF SA KL HP SSC SMC W Z PC
					MF SA KL HP SSC SMC W Z PC
	<b>MF</b> = Mill Finish <b>SA</b> = Silver Anodised <b>KL</b> = Basic Colour <b>HP</b> = Special Colour <b>SSC</b> = Smooth Satin Chrome <b>SMC</b> = Smokey Chrome <b>PC</b> = Polished Chrome	<b>W</b> = White <b>Z</b> = Black			









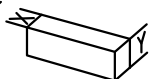
Image	Part Code	Pack	Unit	Application	Colour	
	<b>ACMX09700</b>  Alu. Polish	1	each		MF	✓
					SA	
					KL	
					HP	
					SSC	
					SMC	
					W	
					Z	
					PC	
	<b>ACMX09761</b>  Maxi Gloss	1	each		MF	
					SA	
					KL	
					HP	
					SSC	
					SMC	
					W	
					Z	
					PC	
	<b>ACMX09762</b>  Alu. Bright	1	each		MF	
					SA	
					KL	
					HP	
					SSC	
					SMC	
					W	
					Z	
					PC	
	<b>ACMX09763</b>  Teflon Spray	1	each		MF	
					SA	
					KL	
					HP	
					SSC	
					SMC	
					W	
					Z	
					PC	
	<b>ACMX09764</b>  Maxi Clean	1	each		MF	
					SA	
					KL	
					HP	
					SSC	
					SMC	
					W	
					Z	
					PC	
 T-BARS ACVG65=2.5mm ACVG66=3.0mm ACVL150=4.0mm	 Screw (Grub)	<b>MF</b> = Mill Finish <b>SA</b> = Silver Anodised <b>KL</b> = Basic Colour <b>HP</b> = Special Colour <b>SSC</b> = Smooth Satin Chrome <b>SMC</b> = Smokey Chrome <b>PC</b> = Polished Chrome	<b>W</b> = White <b>Z</b> = Black	 		

Image	Part Code	Pack	Unit	Application	Colour
	<b>ACMX09765</b>  Alu. Cleaner	<b>1</b>	<b>each</b>		MF SA KL HP SSC SMC W Z PC
	<b>ACMX09770</b>  Roll & Wrap 100mm	<b>1</b>	<b>each</b>		MF SA KL HP SSC SMC W Z PC
	<b>ACMX09775</b>  Grip Handwrap	<b>1</b>	<b>each</b>		MF SA KL HP SSC SMC W Z PC
	<b>ACMX09801</b>  Protective Tape 50mm	<b>1</b>	<b>each</b>		MF SA KL HP SSC SMC W Z PC
	<b>ACMX09802</b>  Protective Tape 70mm	<b>1</b>	<b>each</b>		MF SA KL HP SSC SMC W Z PC
 <p>T-BARS ACVG65=2.5mm ACVG66=3.0mm ACVL150=4.0mm</p>  <p>Screw (Grub)</p>	<b>MF</b> = Mill Finish <b>SA</b> = Silver Anodised <b>KL</b> = Basic Colour <b>HP</b> = Special Colour <b>SSC</b> = Smooth Satin Chrome <b>SMC</b> = Smokey Chrome <b>PC</b> = Polished Chrome	<b>W</b> = White <b>Z</b> = Black	 		









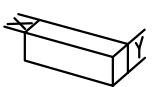



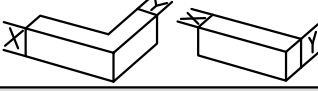
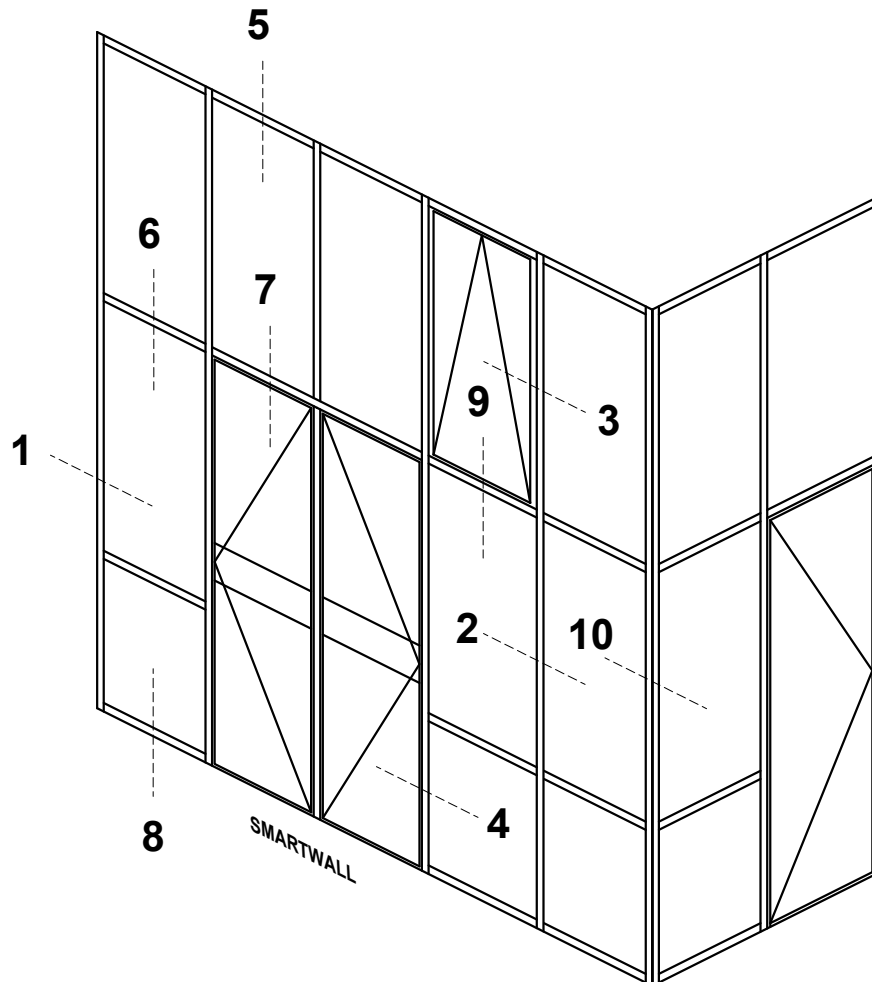
Image	Part Code	Pack	Unit	Application	Colour																		
	<b>ACMX09803</b>  Protective Tape 100mm	<b>1</b>	<b>each</b>		<table border="1"> <tr><td>MF</td><td></td></tr> <tr><td>SA</td><td></td></tr> <tr><td>KL</td><td></td></tr> <tr><td>HP</td><td></td></tr> <tr><td>SSC</td><td></td></tr> <tr><td>SMC</td><td></td></tr> <tr><td>W</td><td></td></tr> <tr><td>Z</td><td></td></tr> <tr><td>PC</td><td></td></tr> </table>	MF		SA		KL		HP		SSC		SMC		W		Z		PC	
MF																							
SA																							
KL																							
HP																							
SSC																							
SMC																							
W																							
Z																							
PC																							
	<b>ACSIL04</b>  Sealing Glue Order with suffix of KL colour (eg.ACSIL04KL005) or BL=Black/WP=White/CL=Clear	<b>1</b>	<b>each</b>		<table border="1"> <tr><td>MF</td><td></td></tr> <tr><td>SA</td><td></td></tr> <tr><td>KL</td><td>✓</td></tr> <tr><td>HP</td><td></td></tr> <tr><td>SSC</td><td></td></tr> <tr><td>SMC</td><td></td></tr> <tr><td>W</td><td>✓</td></tr> <tr><td>Z</td><td>✓</td></tr> <tr><td>PC</td><td></td></tr> </table>	MF		SA		KL	✓	HP		SSC		SMC		W	✓	Z	✓	PC	
MF																							
SA																							
KL	✓																						
HP																							
SSC																							
SMC																							
W	✓																						
Z	✓																						
PC																							
	<b>ACSIL05</b>  Rubber Sealant	<b>1</b>	<b>each</b>		<table border="1"> <tr><td>MF</td><td></td></tr> <tr><td>SA</td><td></td></tr> <tr><td>KL</td><td></td></tr> <tr><td>HP</td><td></td></tr> <tr><td>SSC</td><td></td></tr> <tr><td>SMC</td><td></td></tr> <tr><td>W</td><td></td></tr> <tr><td>Z</td><td></td></tr> <tr><td>PC</td><td></td></tr> </table>	MF		SA		KL		HP		SSC		SMC		W		Z		PC	
MF																							
SA																							
KL																							
HP																							
SSC																							
SMC																							
W																							
Z																							
PC																							
	<b>ACSIL08</b>  Silicon Gun	<b>1</b>	<b>each</b>		<table border="1"> <tr><td>MF</td><td></td></tr> <tr><td>SA</td><td></td></tr> <tr><td>KL</td><td></td></tr> <tr><td>HP</td><td></td></tr> <tr><td>SSC</td><td></td></tr> <tr><td>SMC</td><td></td></tr> <tr><td>W</td><td></td></tr> <tr><td>Z</td><td></td></tr> <tr><td>PC</td><td></td></tr> </table>	MF		SA		KL		HP		SSC		SMC		W		Z		PC	
MF																							
SA																							
KL																							
HP																							
SSC																							
SMC																							
W																							
Z																							
PC																							
	<b>ACSIL013</b>  Glue for Mitre	<b>1</b>	<b>each</b>		<table border="1"> <tr><td>MF</td><td></td></tr> <tr><td>SA</td><td></td></tr> <tr><td>KL</td><td></td></tr> <tr><td>HP</td><td></td></tr> <tr><td>SSC</td><td></td></tr> <tr><td>SMC</td><td></td></tr> <tr><td>W</td><td></td></tr> <tr><td>Z</td><td></td></tr> <tr><td>PC</td><td></td></tr> </table>	MF		SA		KL		HP		SSC		SMC		W		Z		PC	
MF																							
SA																							
KL																							
HP																							
SSC																							
SMC																							
W																							
Z																							
PC																							
 <p>T-BARS ACVG66=2.5mm ACVG66=3.0mm ACVL150=4.0mm</p>  <p>Screw (Grub)</p>	<p>MF = Mill Finish SA = Silver Anodised KL = Basic Colour HP = Special Colour SSC = Smooth Satin Chrome SMC = Smokey Chrome PC = Polished Chrome</p>	<p>W = White Z = Black</p>	 																				

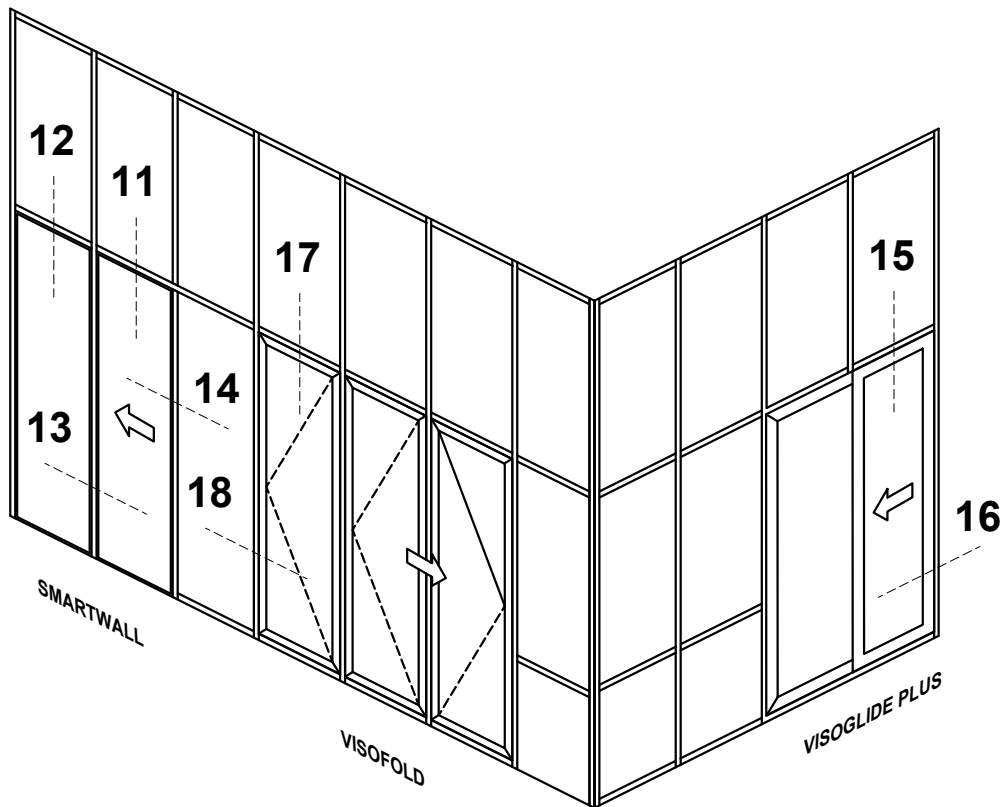
Image	Part Code	Pack	Unit	Application	Colour
	<b>ACSIL014</b>  <b>Anti-Corrosion Coating</b>	<b>1</b>	<b>each</b>		MF <input checked="" type="checkbox"/>
					SA <input type="checkbox"/>
					KL <input type="checkbox"/>
					HP <input type="checkbox"/>
					SSC <input type="checkbox"/>
					SMC <input type="checkbox"/>
					W <input type="checkbox"/>
					Z <input type="checkbox"/>
					PC <input type="checkbox"/>
					
SA <input type="checkbox"/>					
KL <input type="checkbox"/>					
HP <input type="checkbox"/>					
SSC <input type="checkbox"/>					
SMC <input type="checkbox"/>					
W <input type="checkbox"/>					
Z <input type="checkbox"/>					
PC <input type="checkbox"/>					
					SA <input type="checkbox"/>
					KL <input type="checkbox"/>
					HP <input type="checkbox"/>
					SSC <input type="checkbox"/>
					SMC <input type="checkbox"/>
					W <input type="checkbox"/>
					Z <input type="checkbox"/>
					PC <input type="checkbox"/>
SA <input type="checkbox"/>					
KL <input type="checkbox"/>					
HP <input type="checkbox"/>					
SSC <input type="checkbox"/>					
SMC <input type="checkbox"/>					
W <input type="checkbox"/>					
Z <input type="checkbox"/>					
PC <input type="checkbox"/>					
 <p>T-BARS ACVG65=2.5mm ACVG66=3.0mm ACVL150=4.0mm</p> <p>Screw (Grub)</p>	<b>MF = Mill Finish</b> <b>SA = Silver Anodised</b> <b>KL = Basic Colour</b> <b>HP = Special Colour</b> <b>SSC = Smooth Satin Chrome</b> <b>SMC = Smokey Chrome</b> <b>PC = Polished Chrome</b>				
					SA <input type="checkbox"/>
					KL <input type="checkbox"/>
					HP <input type="checkbox"/>
					SSC <input type="checkbox"/>
					SMC <input type="checkbox"/>
					W <input type="checkbox"/>
					Z <input type="checkbox"/>
					PC <input type="checkbox"/>
SA <input type="checkbox"/>					
KL <input type="checkbox"/>					
HP <input type="checkbox"/>					
SSC <input type="checkbox"/>					
SMC <input type="checkbox"/>					
W <input type="checkbox"/>					
Z <input type="checkbox"/>					
PC <input type="checkbox"/>					
					

**Section C**

**Sections**

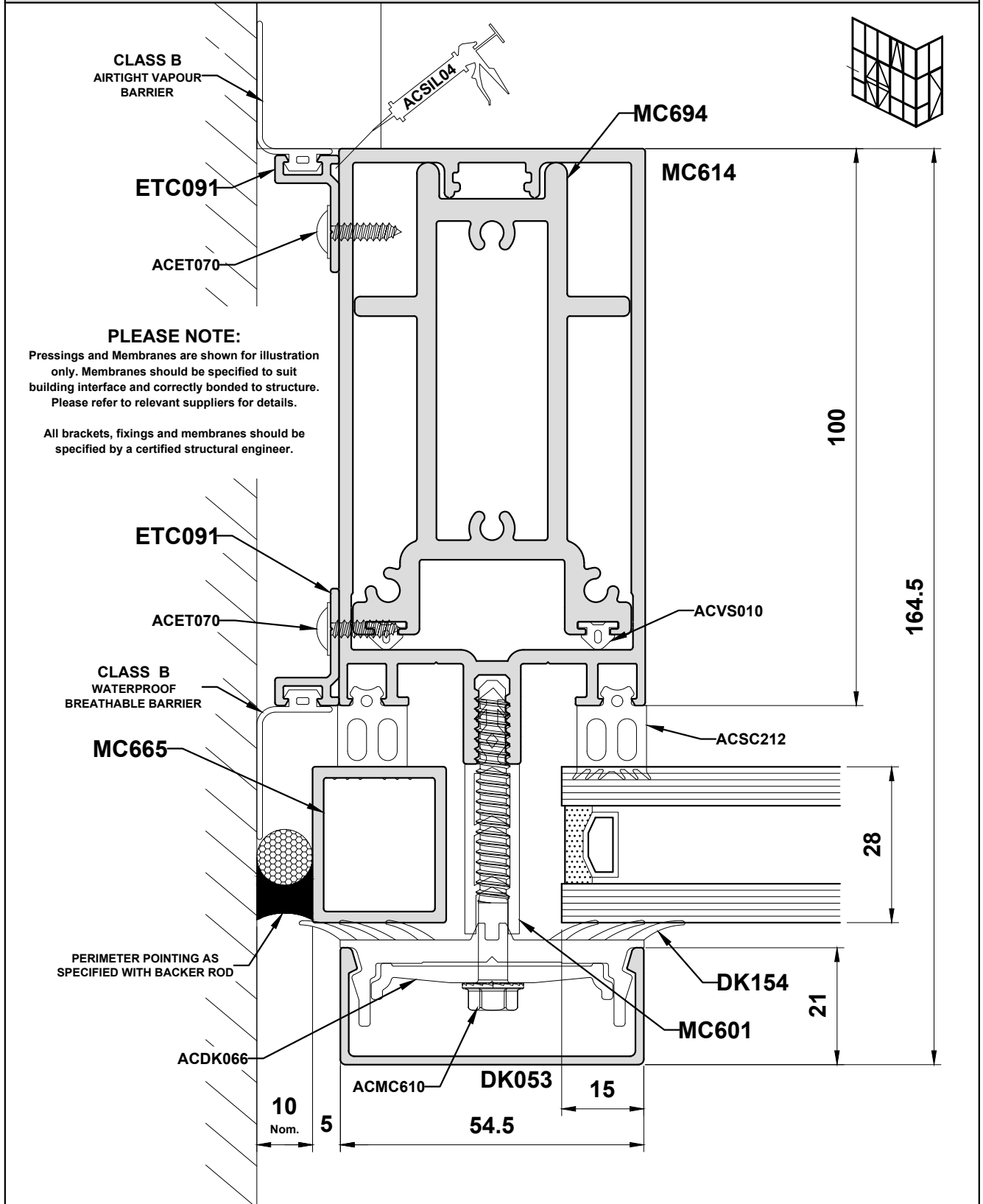
**Scale Elevations**





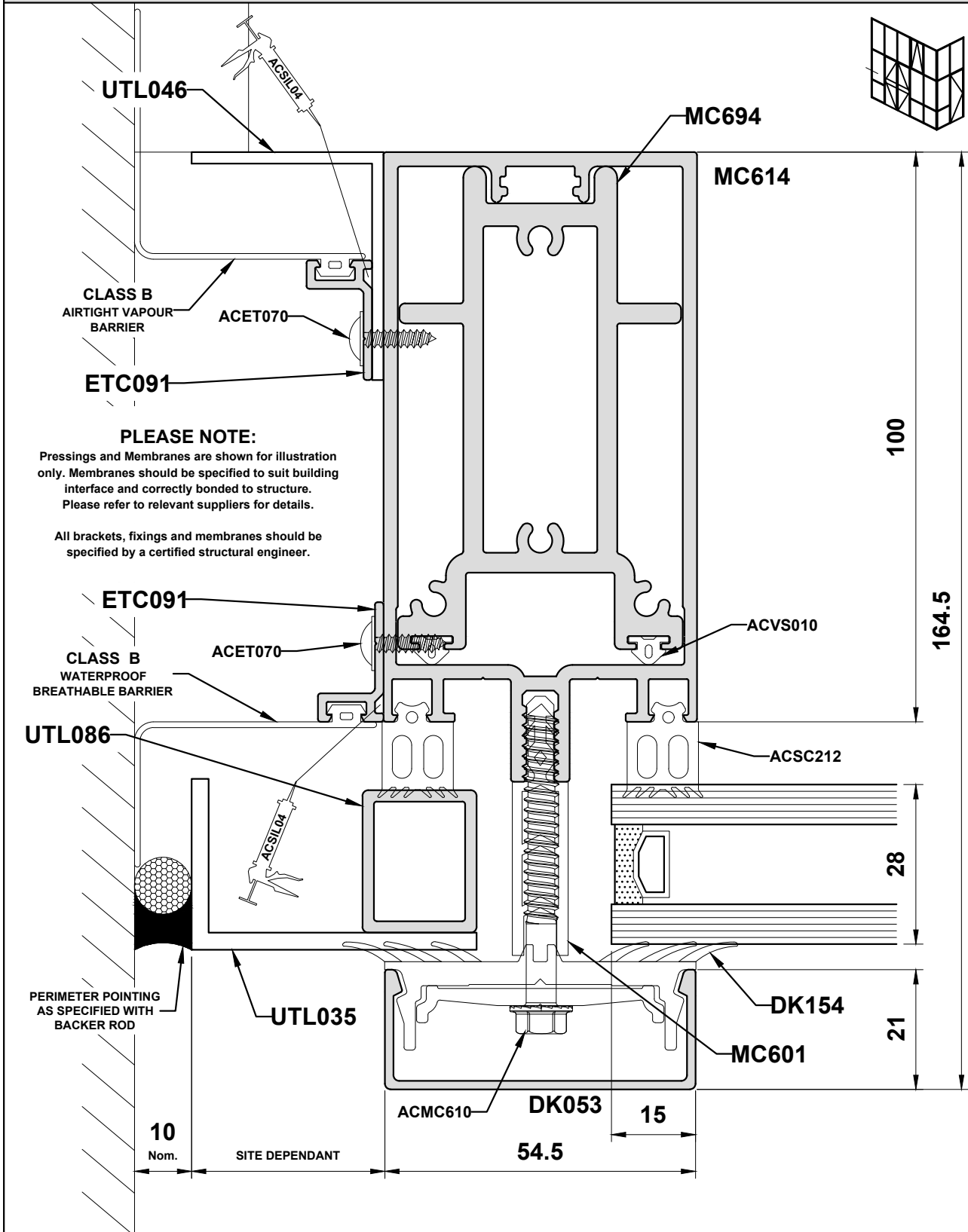


**Detail 1a - End Mullion**



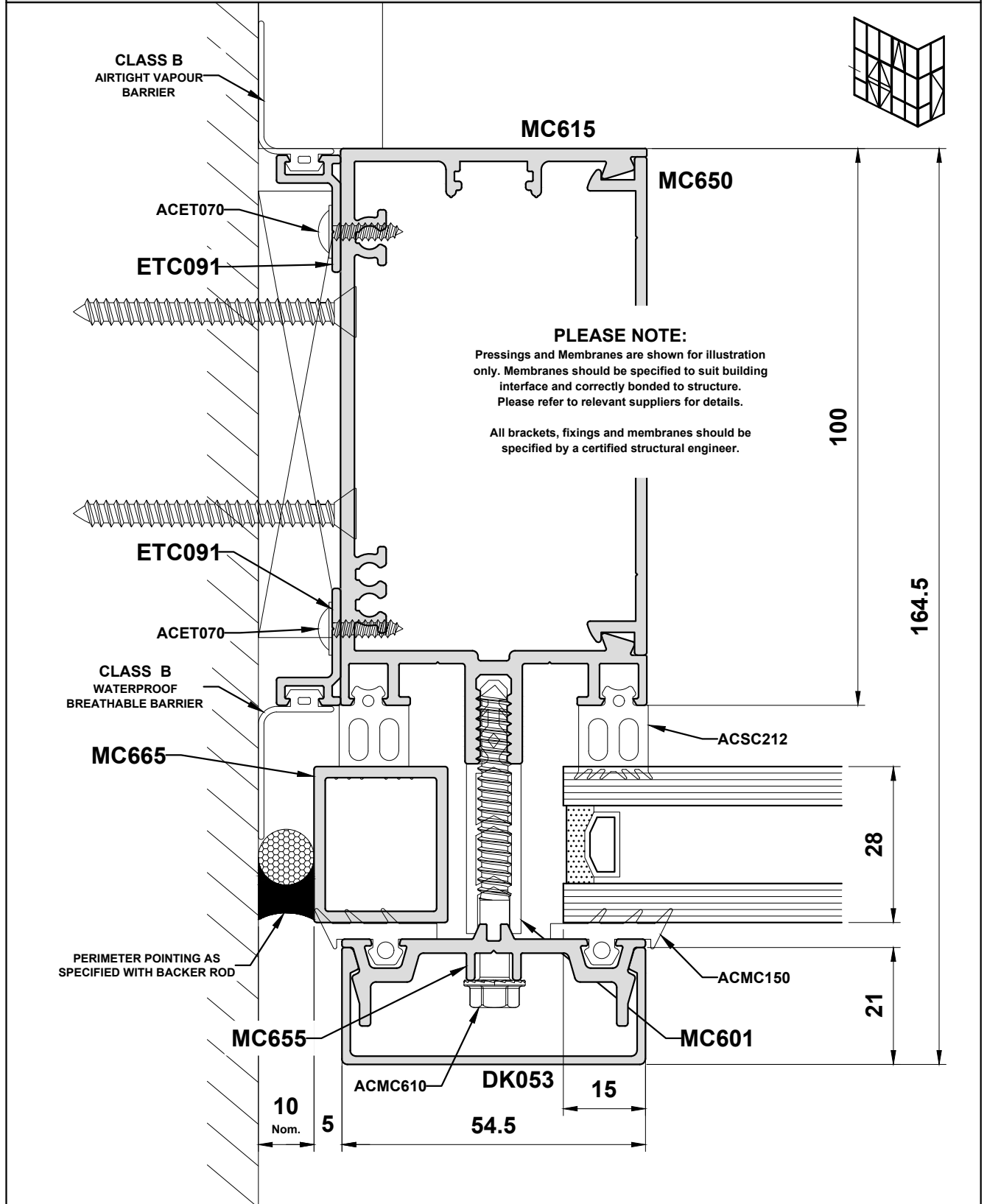
**Do Not Scale From This Drawing**

**Detail 1b - End Mullion**



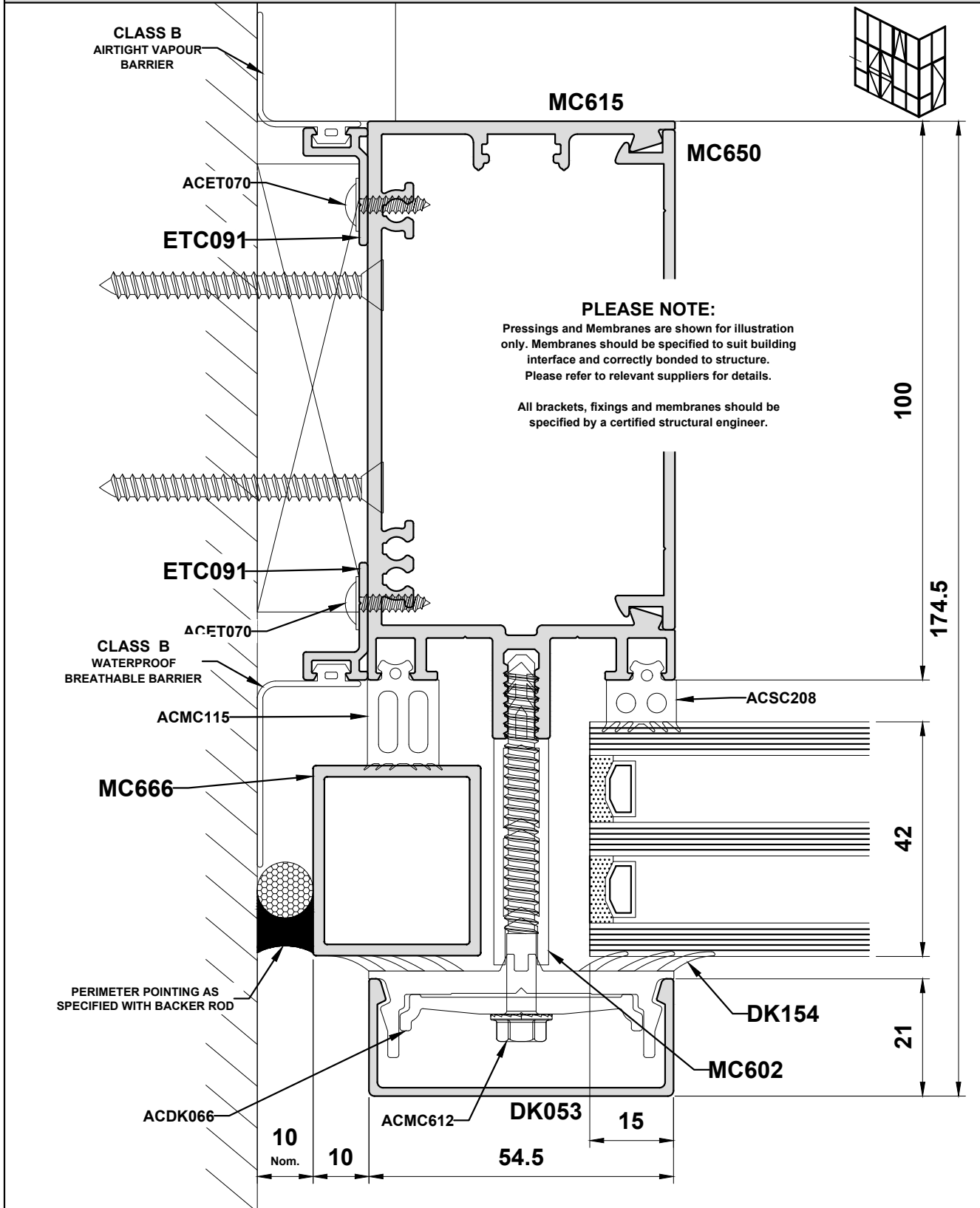
**Do Not Scale From This Drawing**

**Detail 1c - Open Box Mullion**



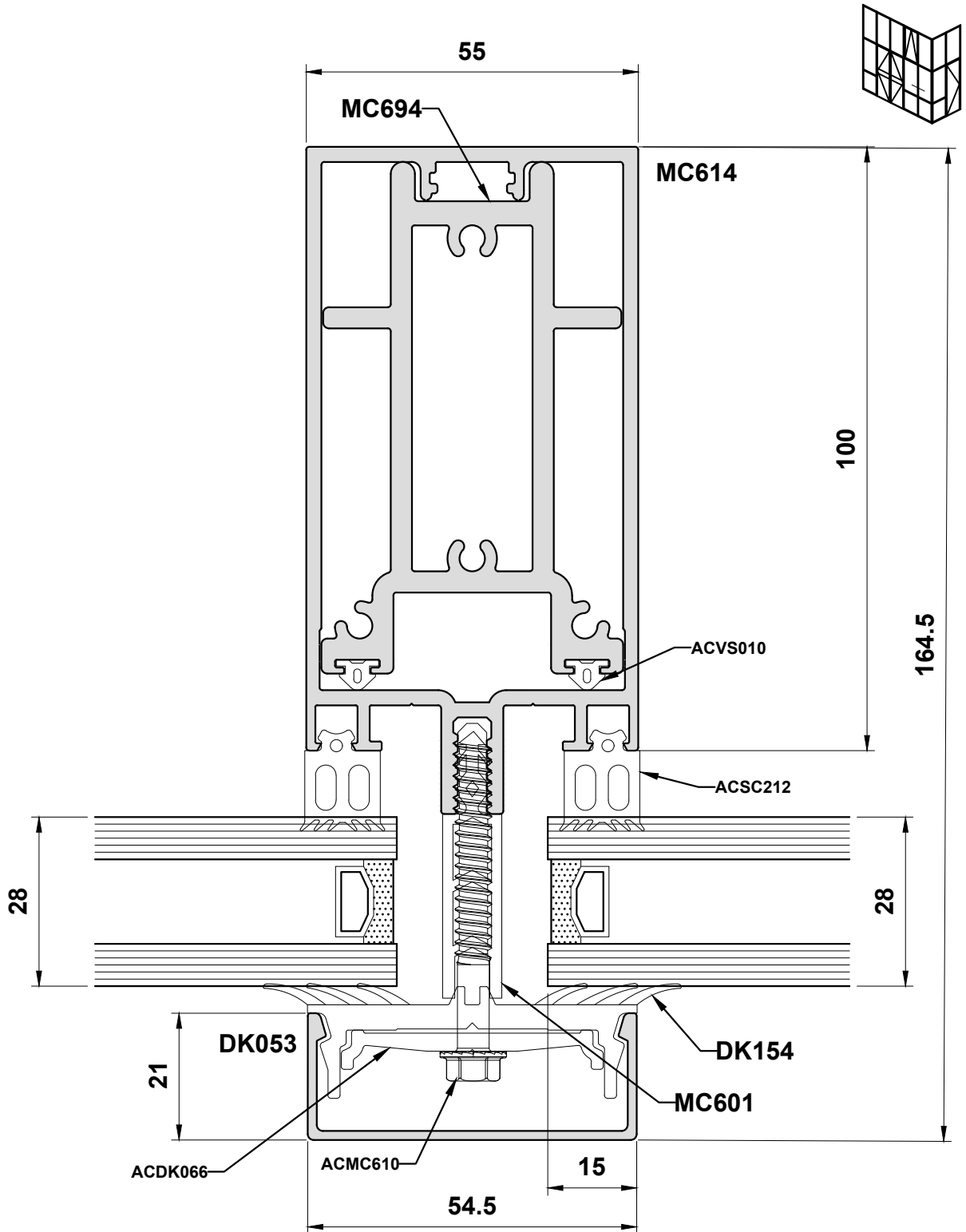
**Do Not Scale From This Drawing**

**Detail 1d - Open Box Mullion**



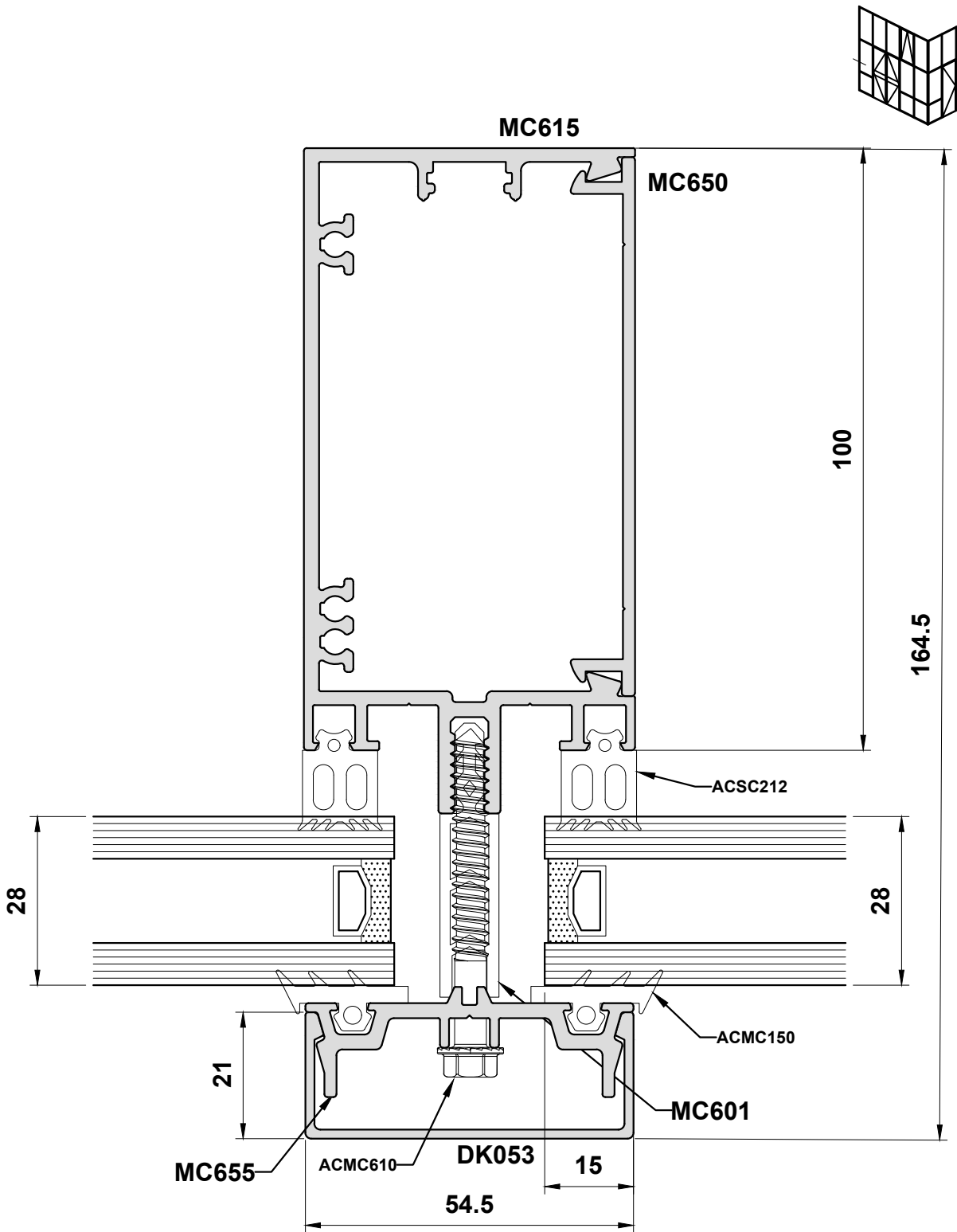
**Do Not Scale From This Drawing**

**Detail 2a - Mullion Detail**



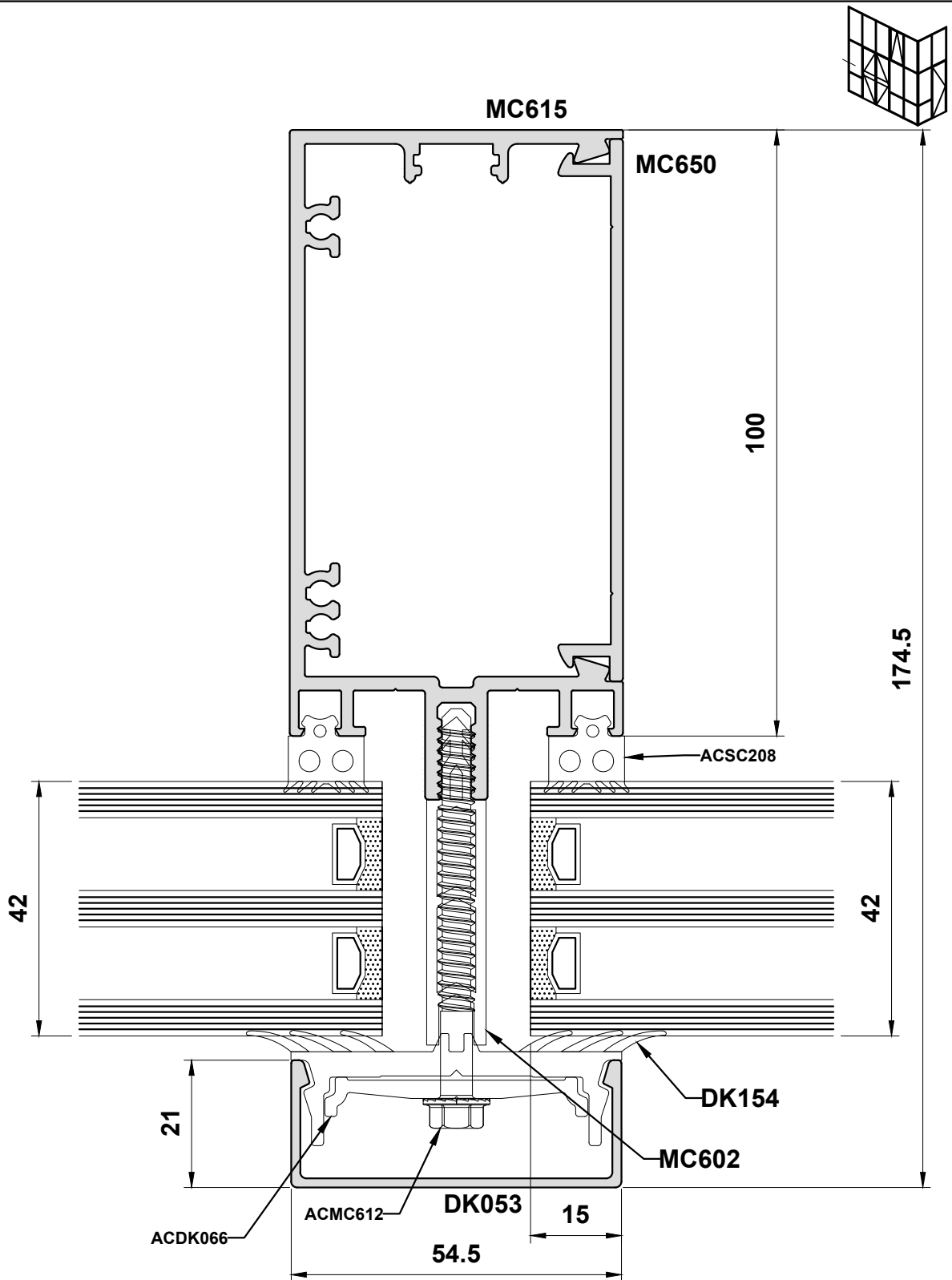
**Do Not Scale From This Drawing**

**Detail 2b - Mullion Detail**



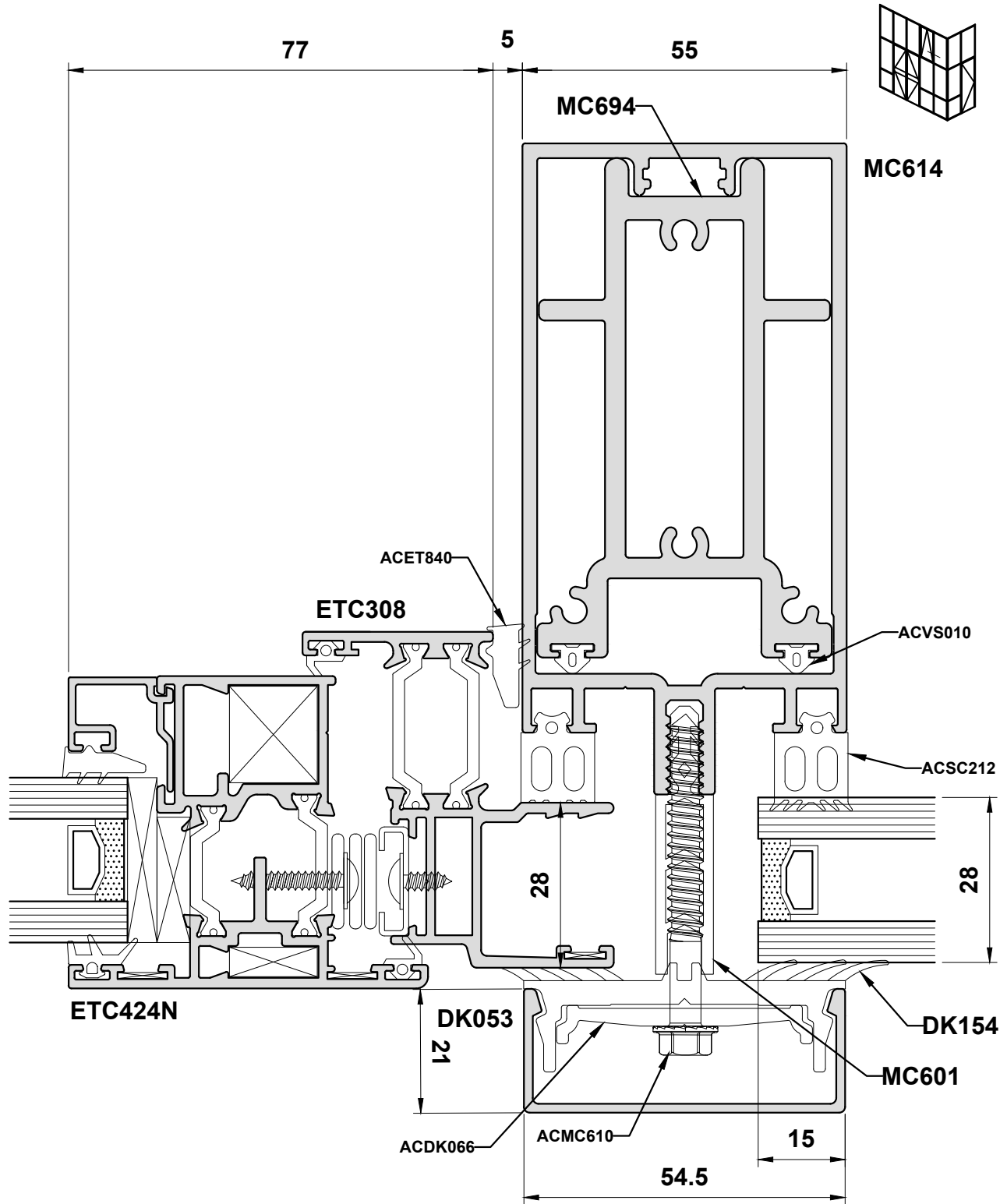
**Do Not Scale From This Drawing**

**Detail 2c - Mullion Detail**



**Do Not Scale From This Drawing**

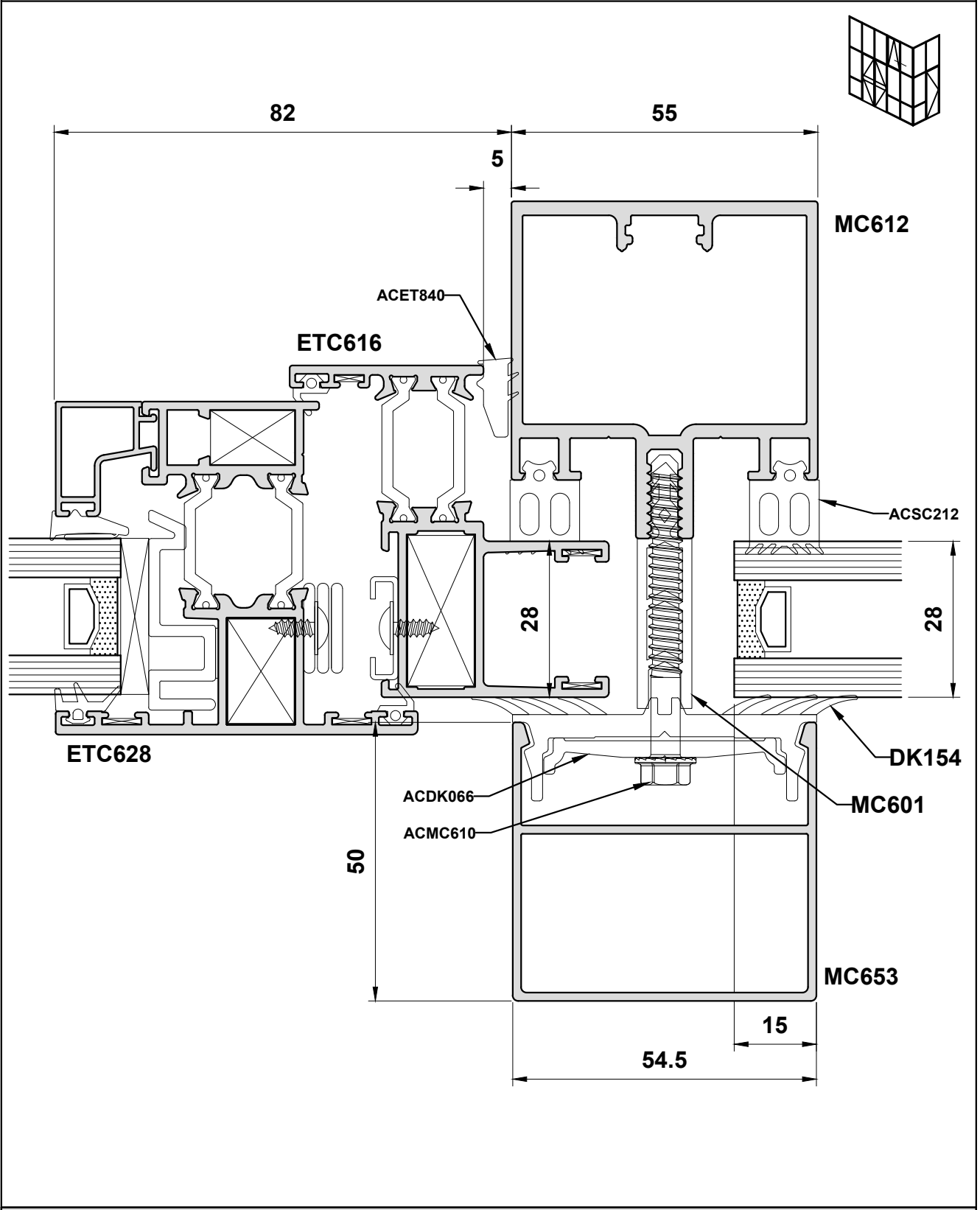
**Detail 3a - Mullion Detail**



**Do Not Scale From This Drawing**

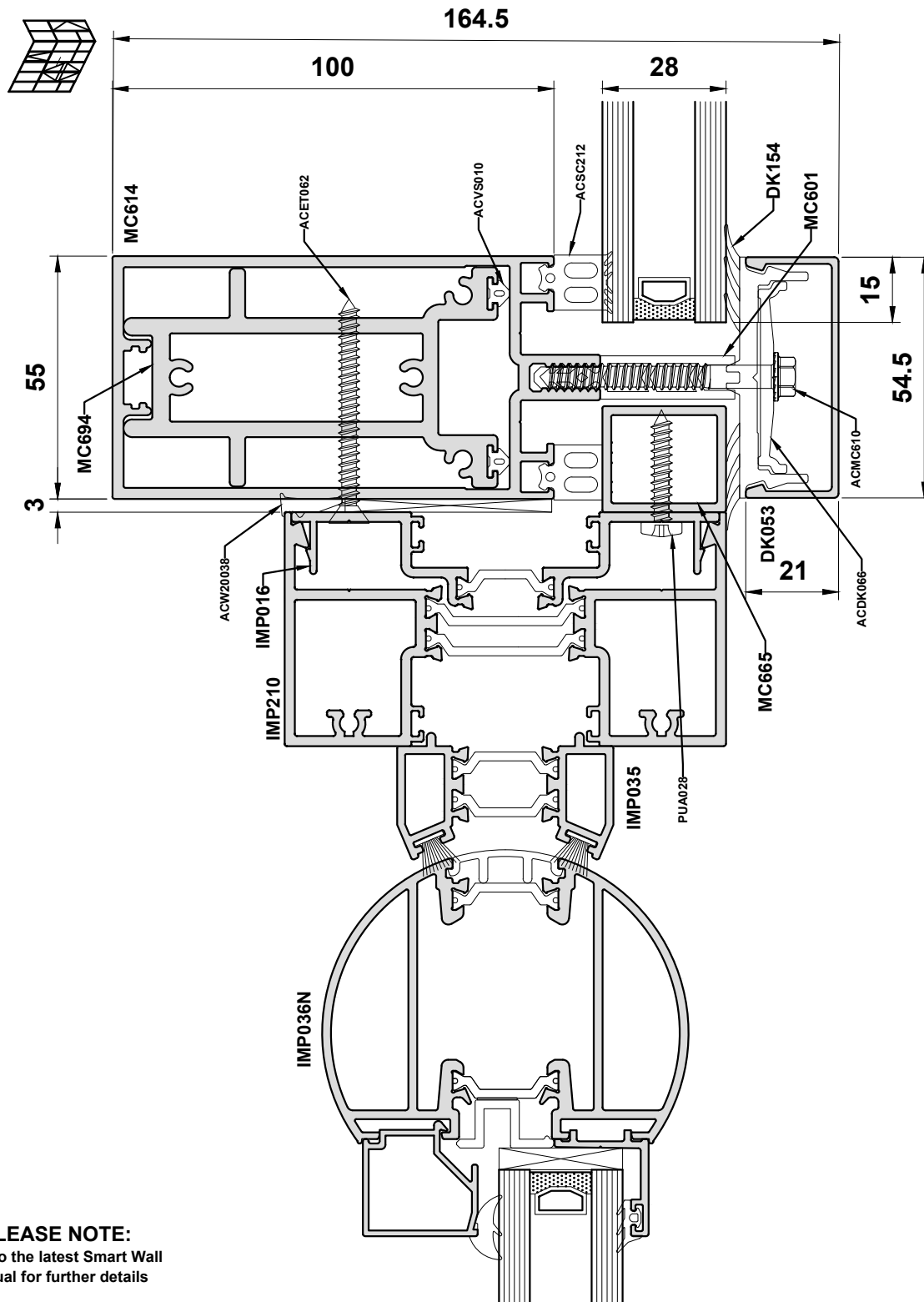


**Detail 3b - Mullion Detail**



**Do Not Scale From This Drawing**

**Detail 4a - Mullion with Smart Wall Jamb**

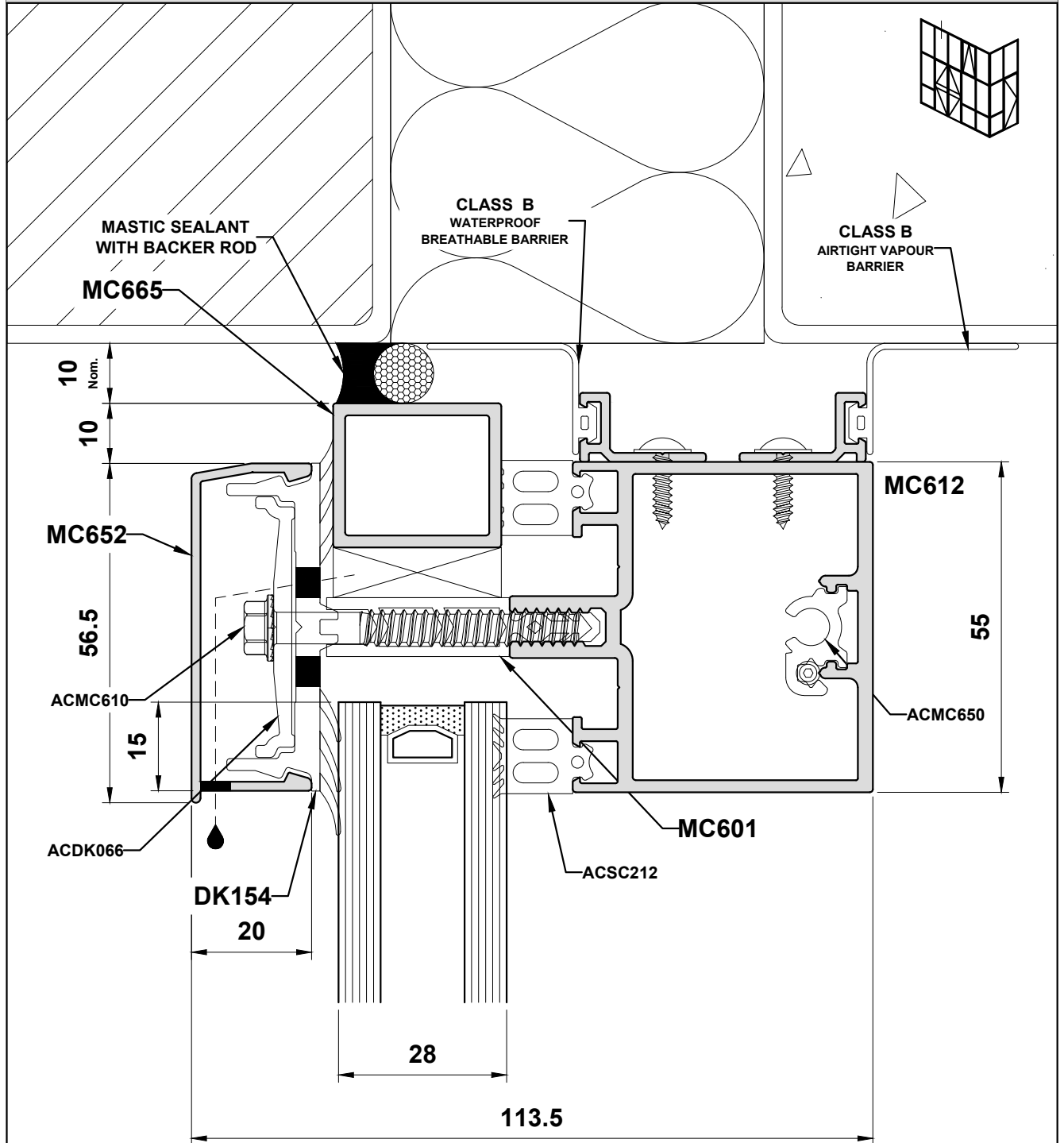


**PLEASE NOTE:**  
Refer to the latest Smart Wall  
manual for further details

**NOT TO SCALE**

**Do Not Scale From This Drawing**

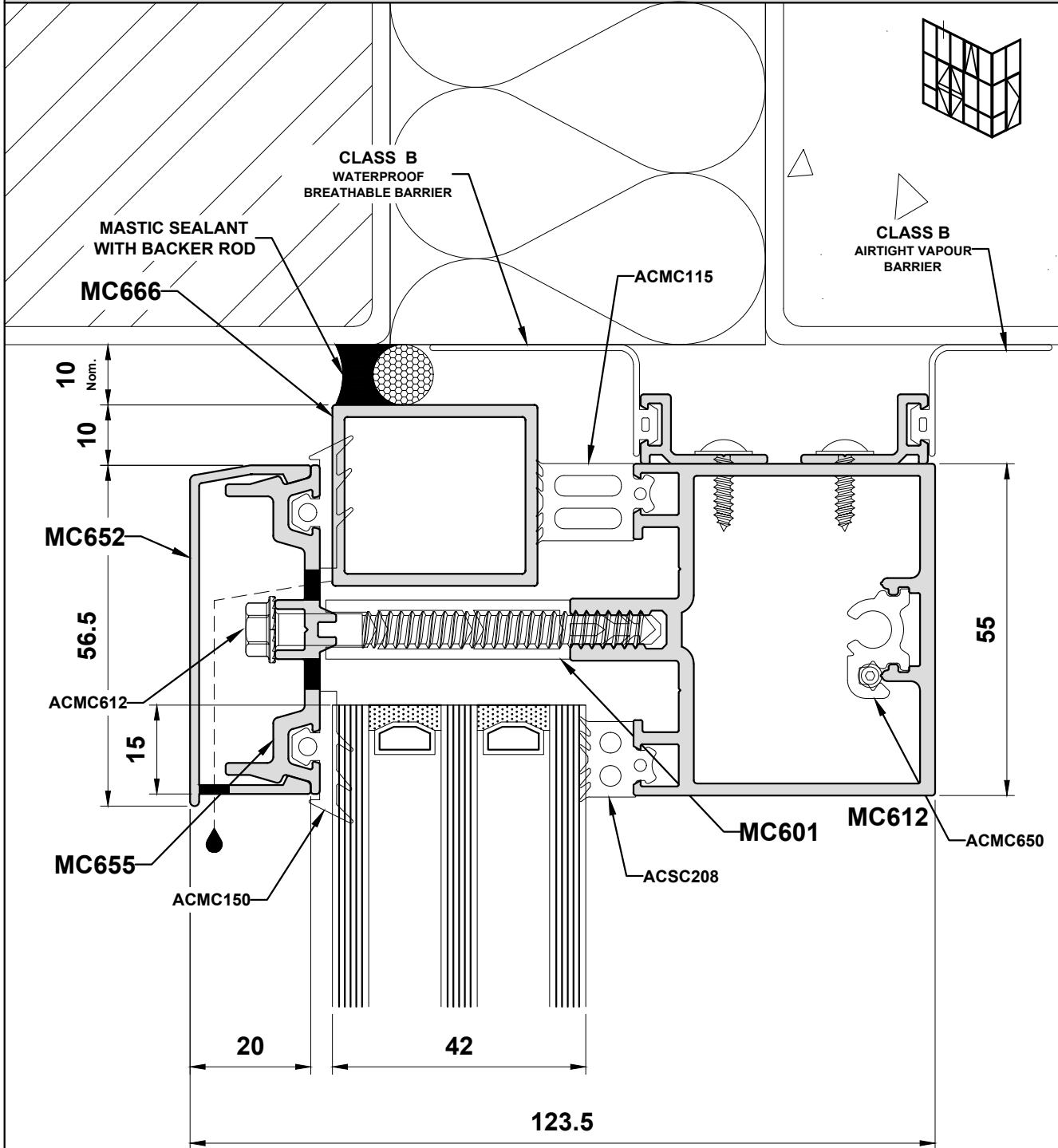
**Detail 5a - Top Transom**



**PLEASE NOTE:**  
Refer to Section E for further  
information on top of mullion fixing

**Do Not Scale From This Drawing**

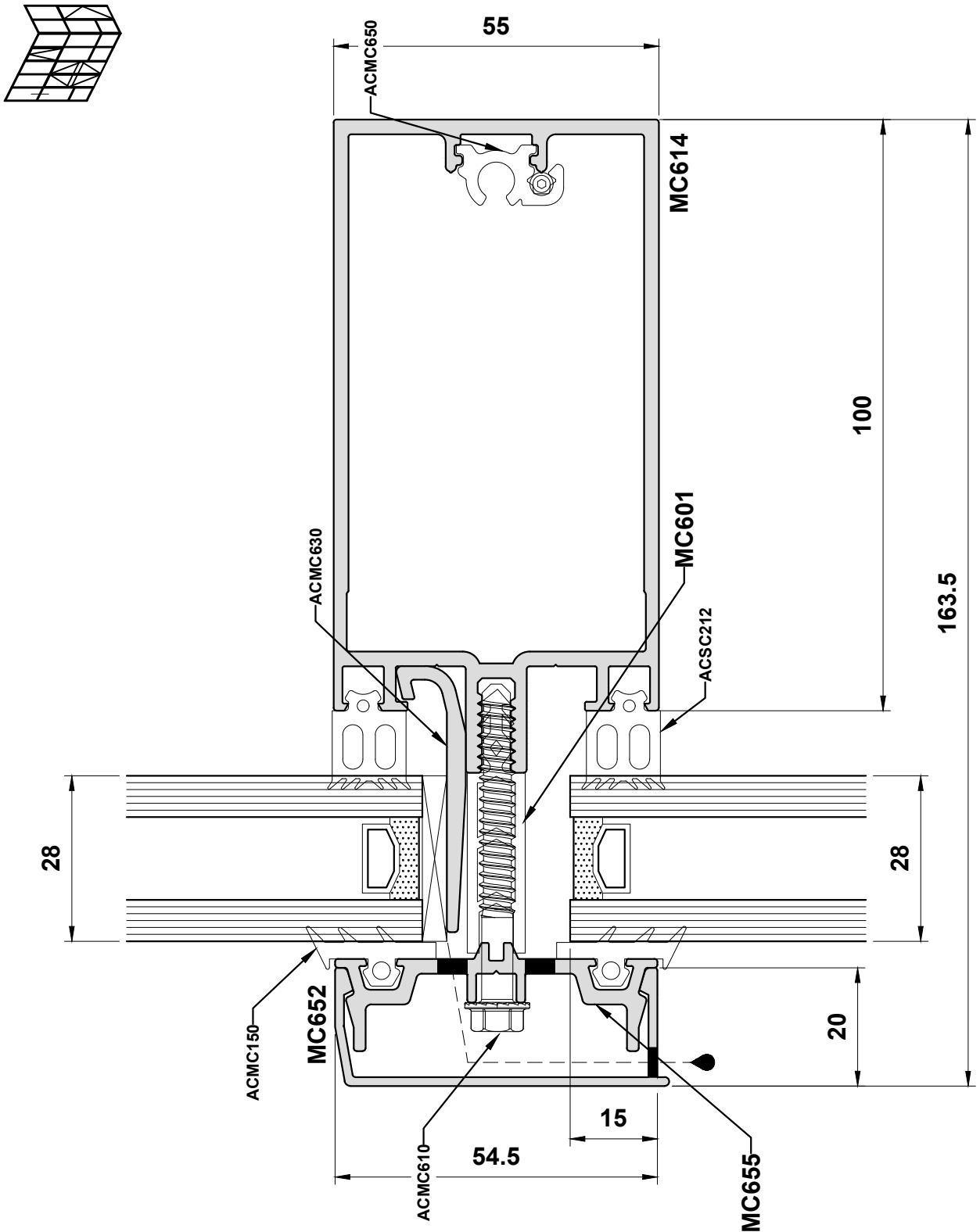
**Detail 5b - Top Transom**



**PLEASE NOTE:**  
Refer to Section E for further  
information on top of mullion fixing

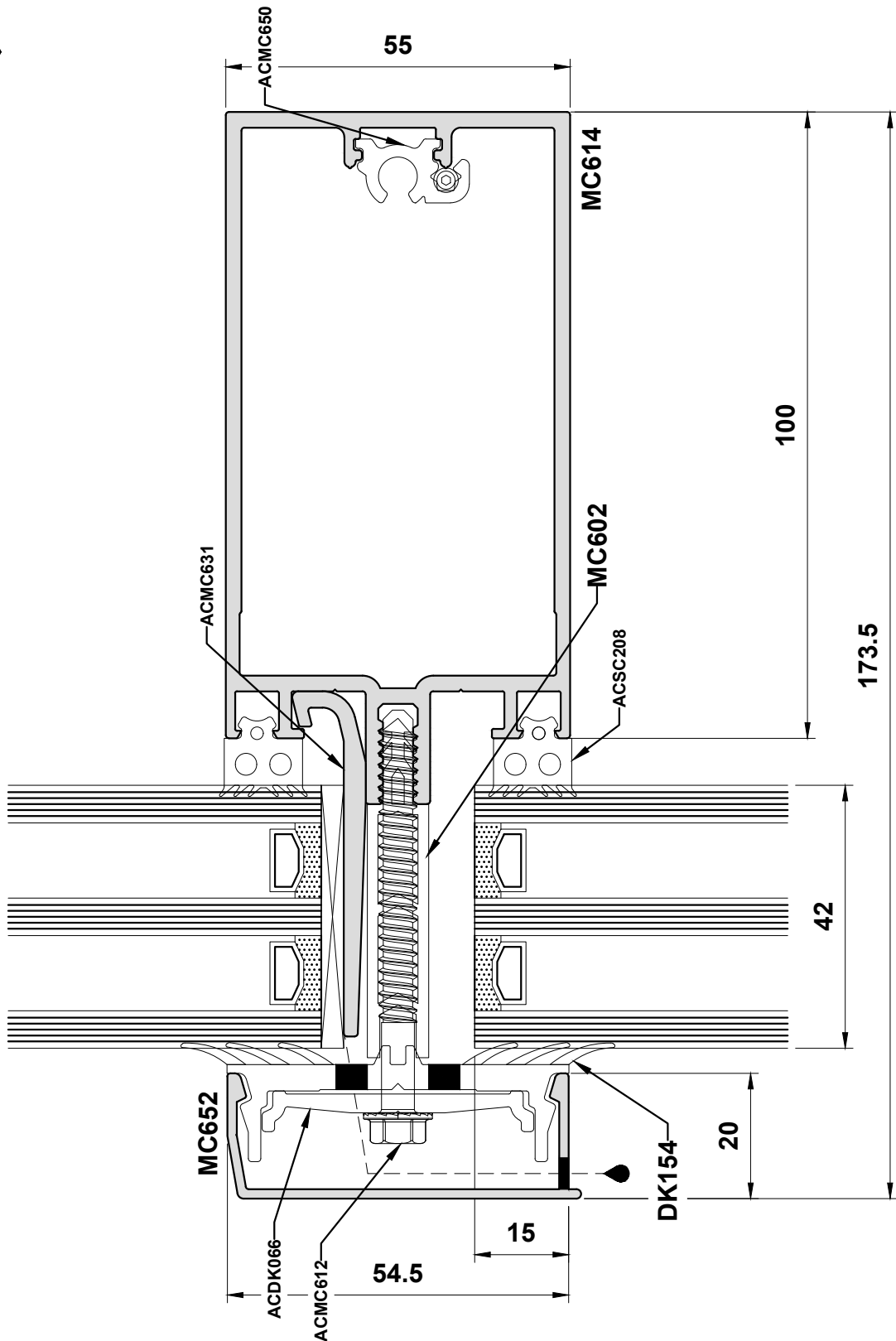
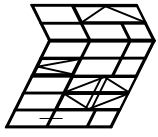
**Do Not Scale From This Drawing**

**Detail 6a - Transom**



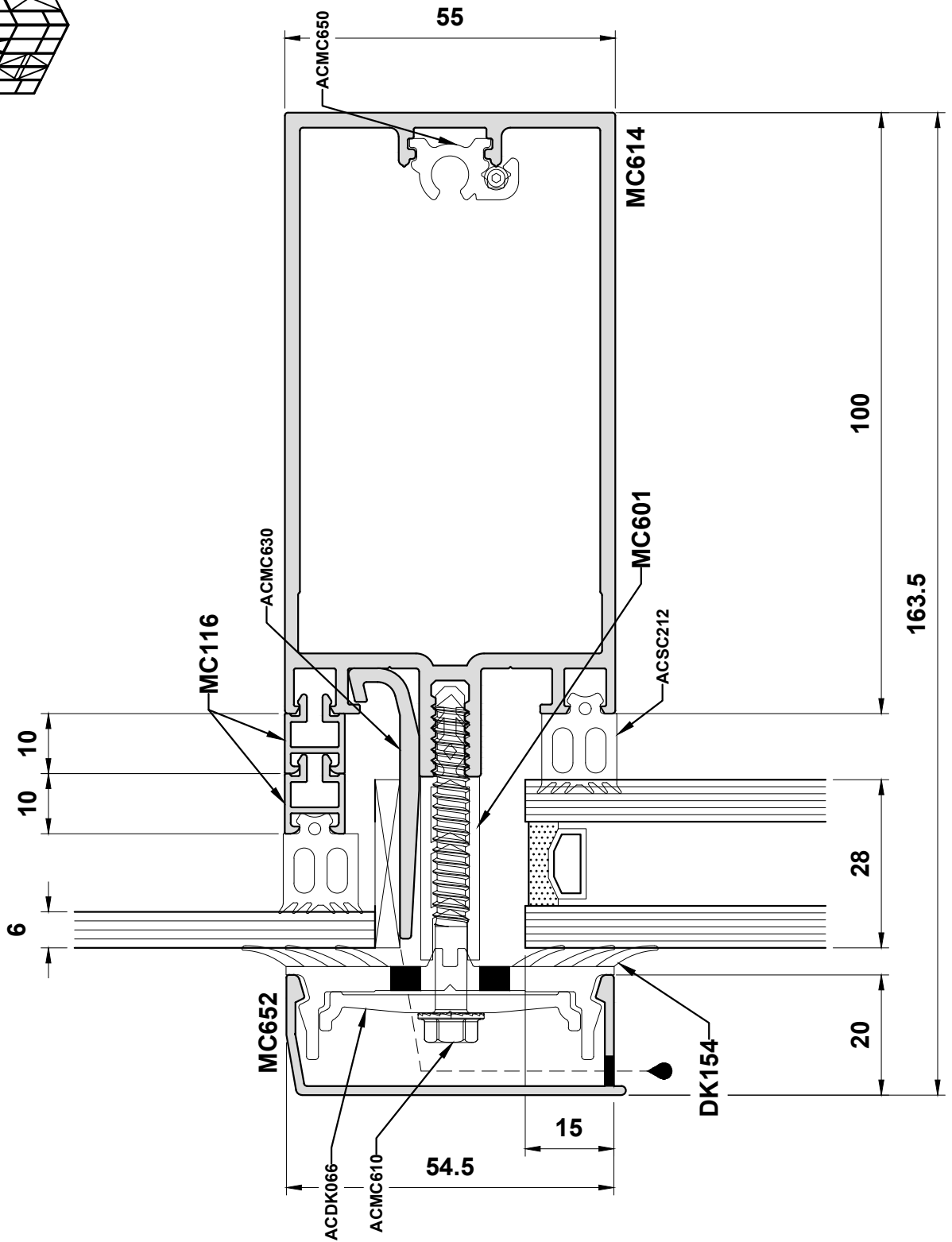
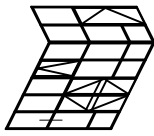
**Do Not Scale From This Drawing**

**Detail 6b - Transom**



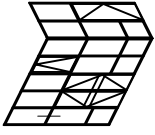
**Do Not Scale From This Drawing**

**Detail 6c - Transom**

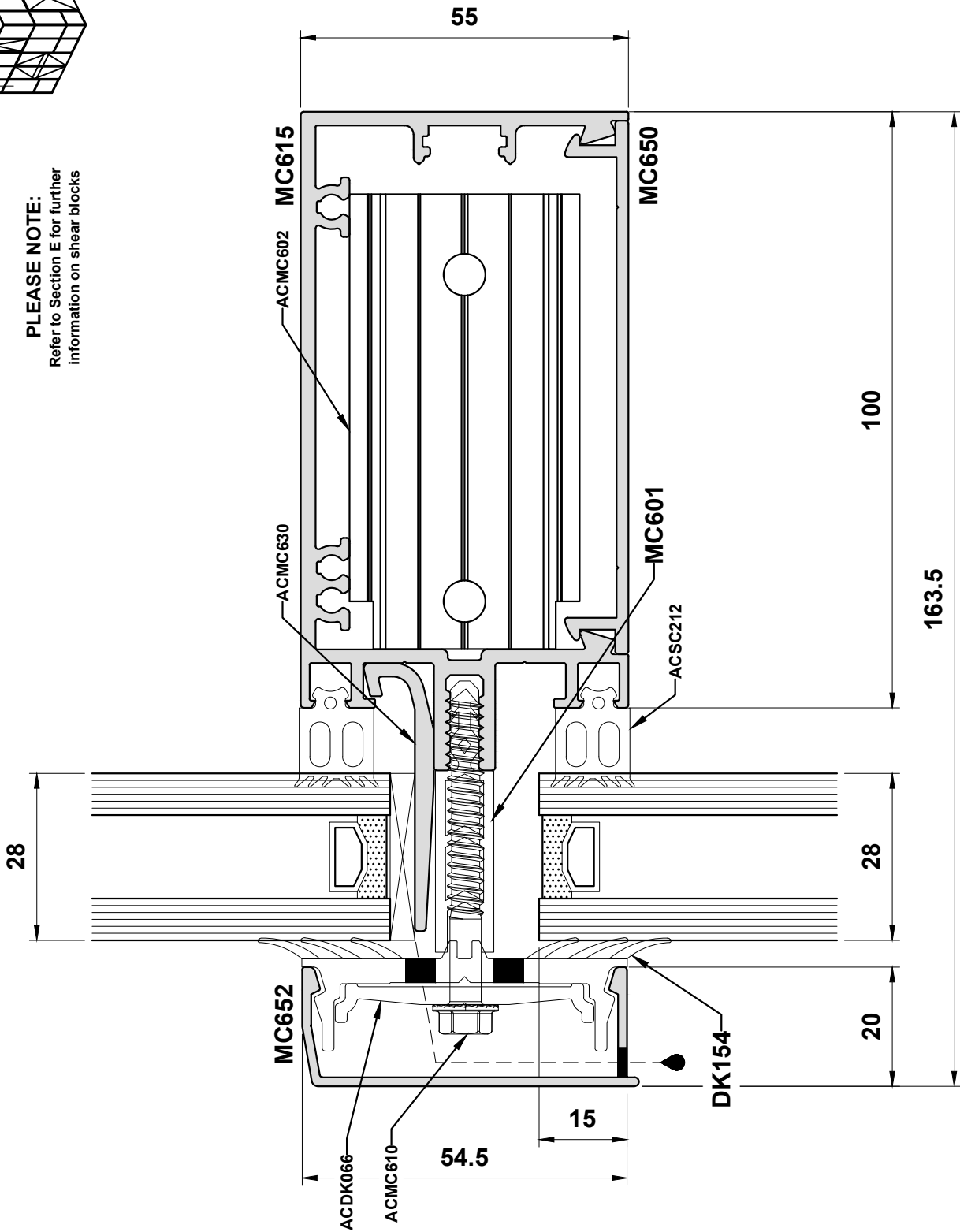


**Do Not Scale From This Drawing**

**Detail 6d - Open Box Transom**



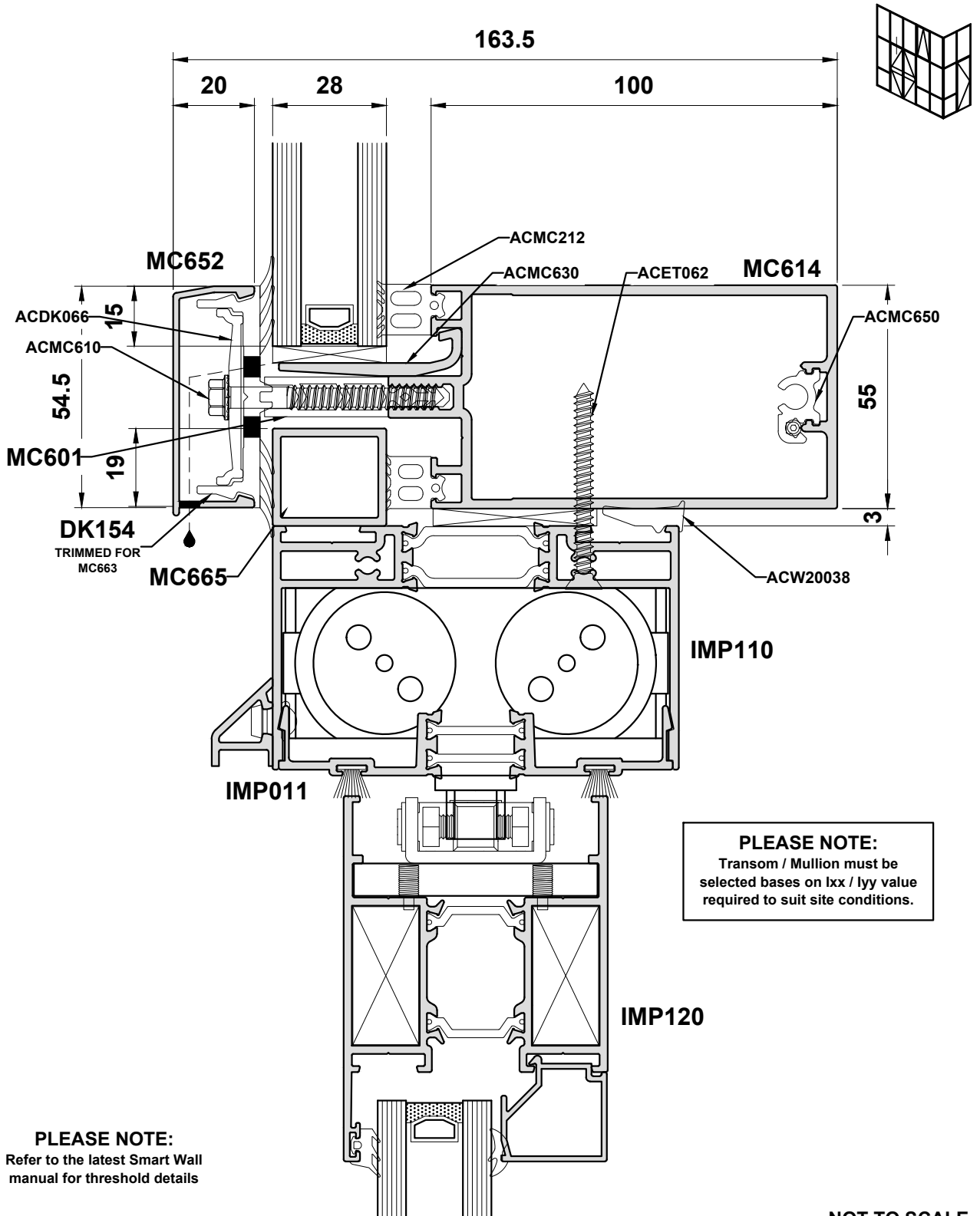
**PLEASE NOTE:**  
Refer to Section E for further  
information on shear blocks



**Do Not Scale From This Drawing**



Detail 7a - Transom Above Door



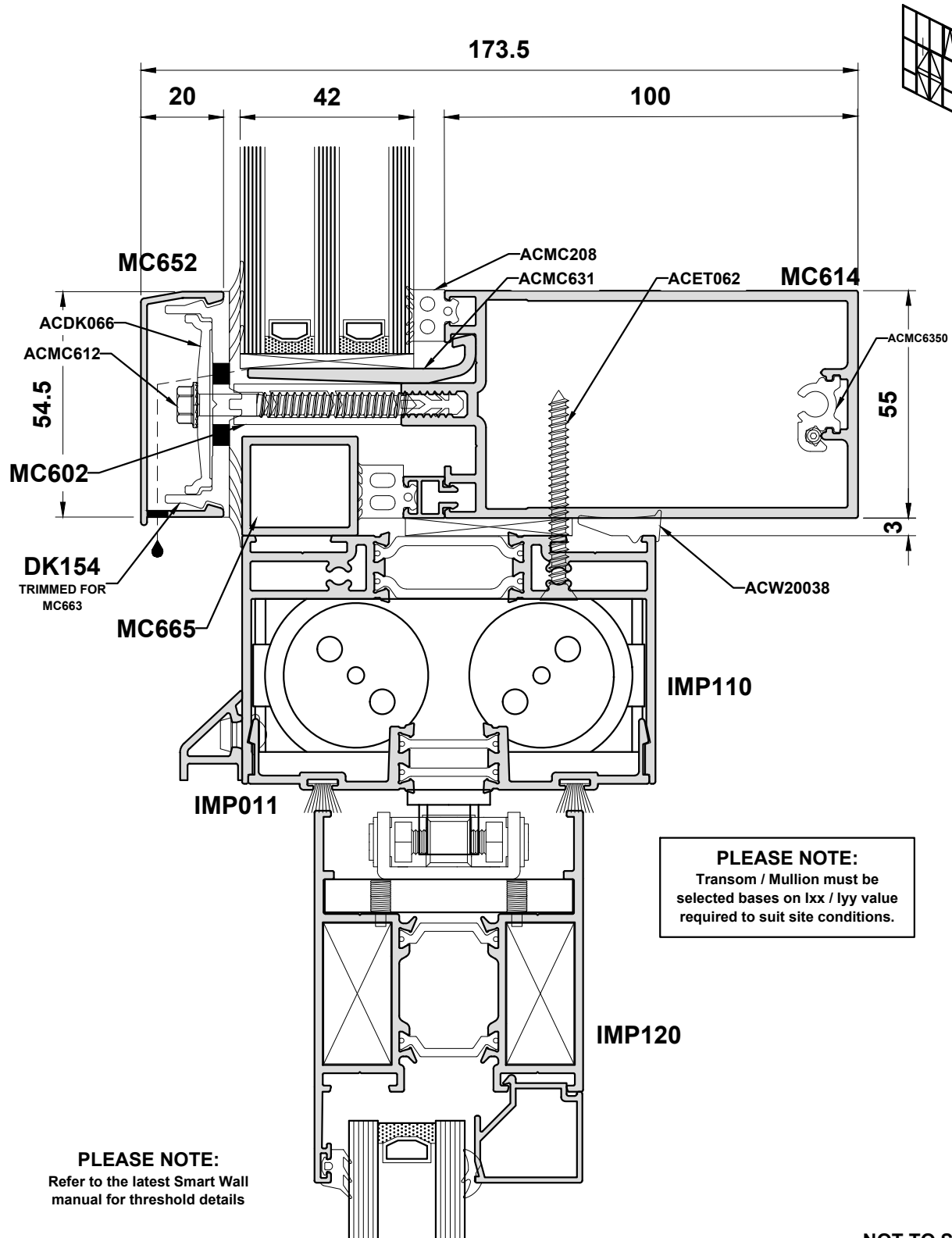
**PLEASE NOTE:**  
Refer to the latest Smart Wall manual for threshold details

**PLEASE NOTE:**  
Transom / Mullion must be selected bases on lxx / lyy value required to suit site conditions.

NOT TO SCALE

**Do Not Scale From This Drawing**

Detail 7b - Transom Above Door



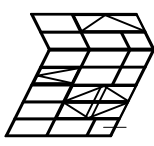
**PLEASE NOTE:**  
Transom / Mullion must be selected based on lxx / lyy value required to suit site conditions.

**PLEASE NOTE:**  
Refer to the latest Smart Wall manual for threshold details

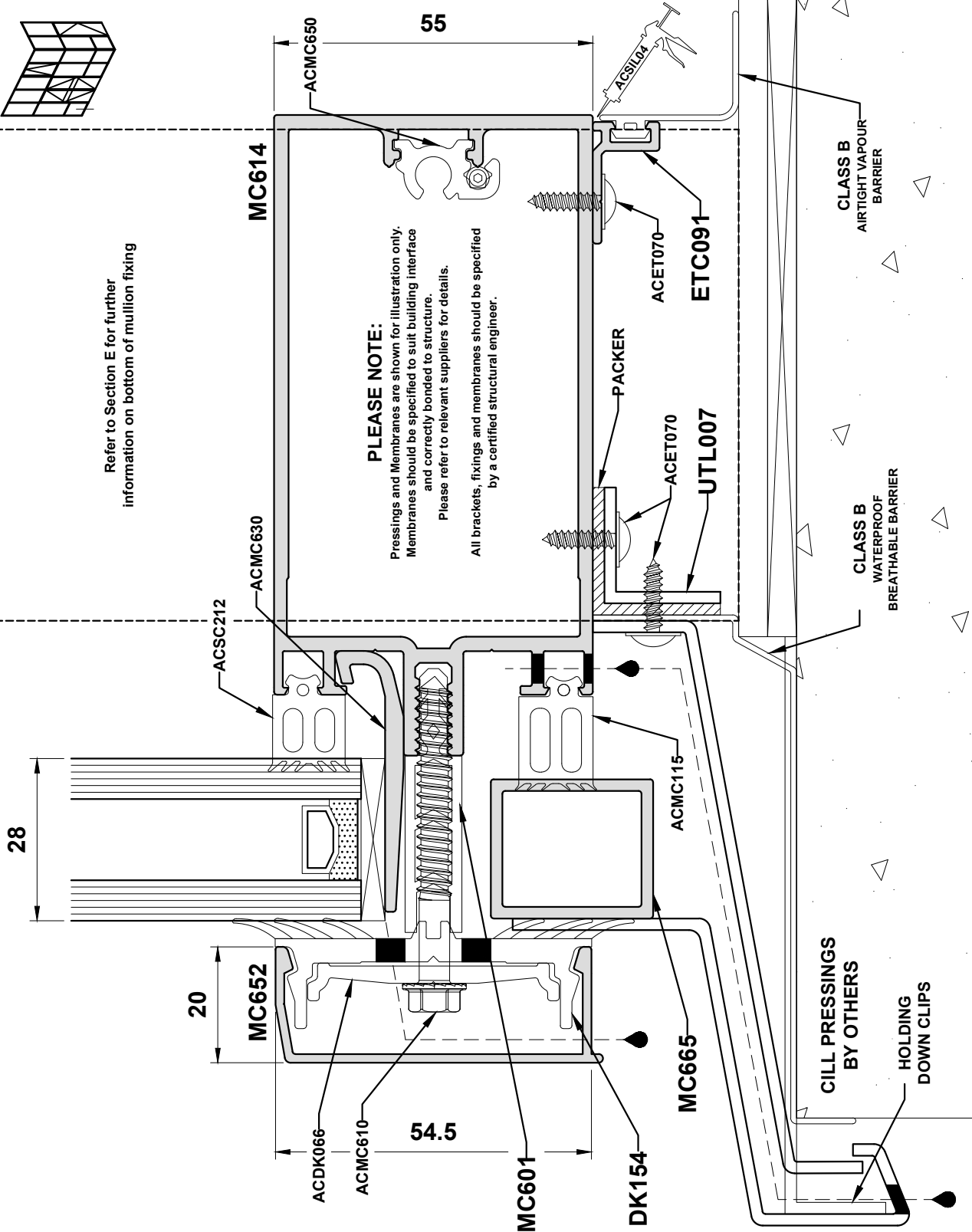
NOT TO SCALE

Do Not Scale From This Drawing

Detail 8a - Cill

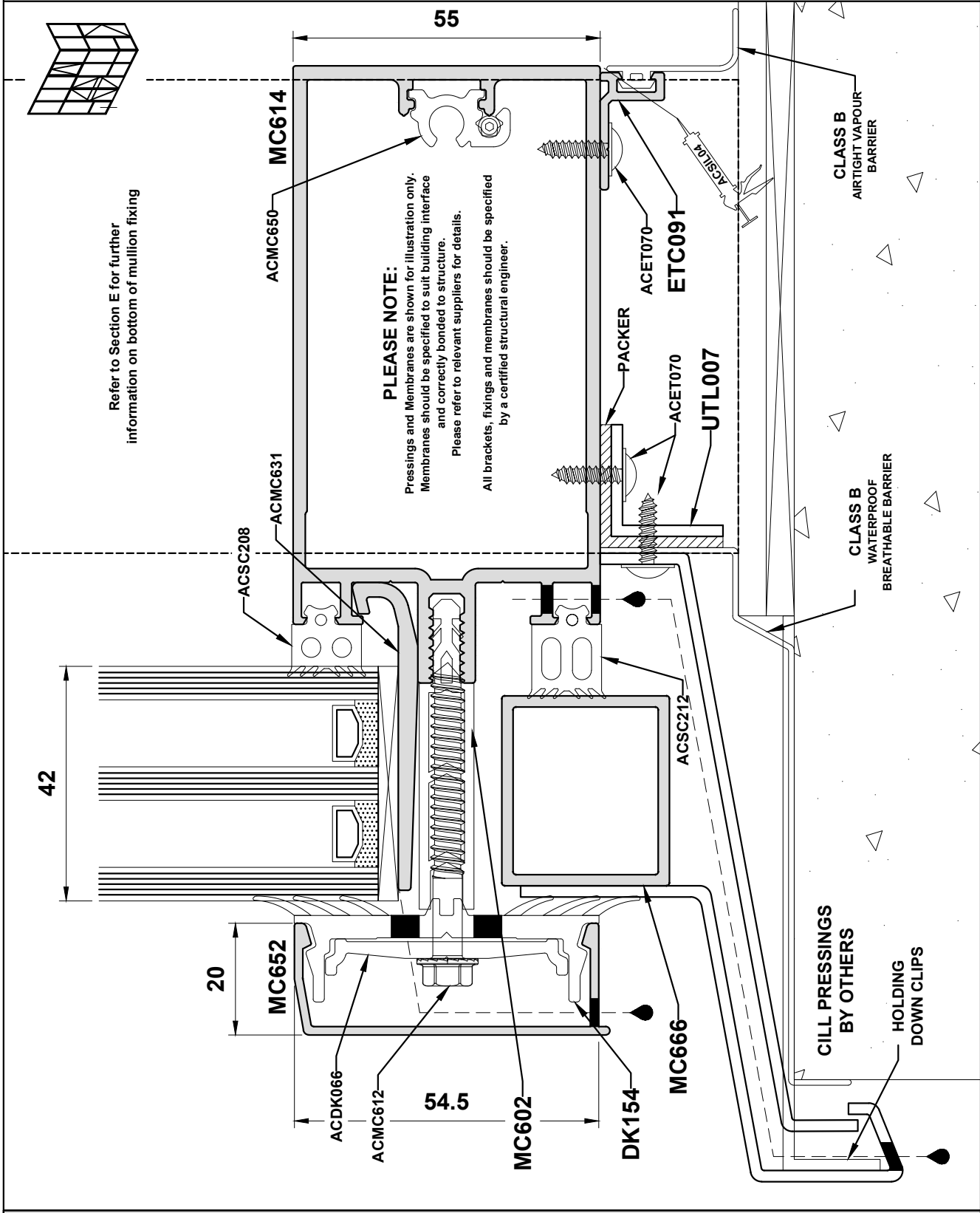


Refer to Section E for further information on bottom of mullion fixing



Do Not Scale From This Drawing

**Detail 8b - Cill**

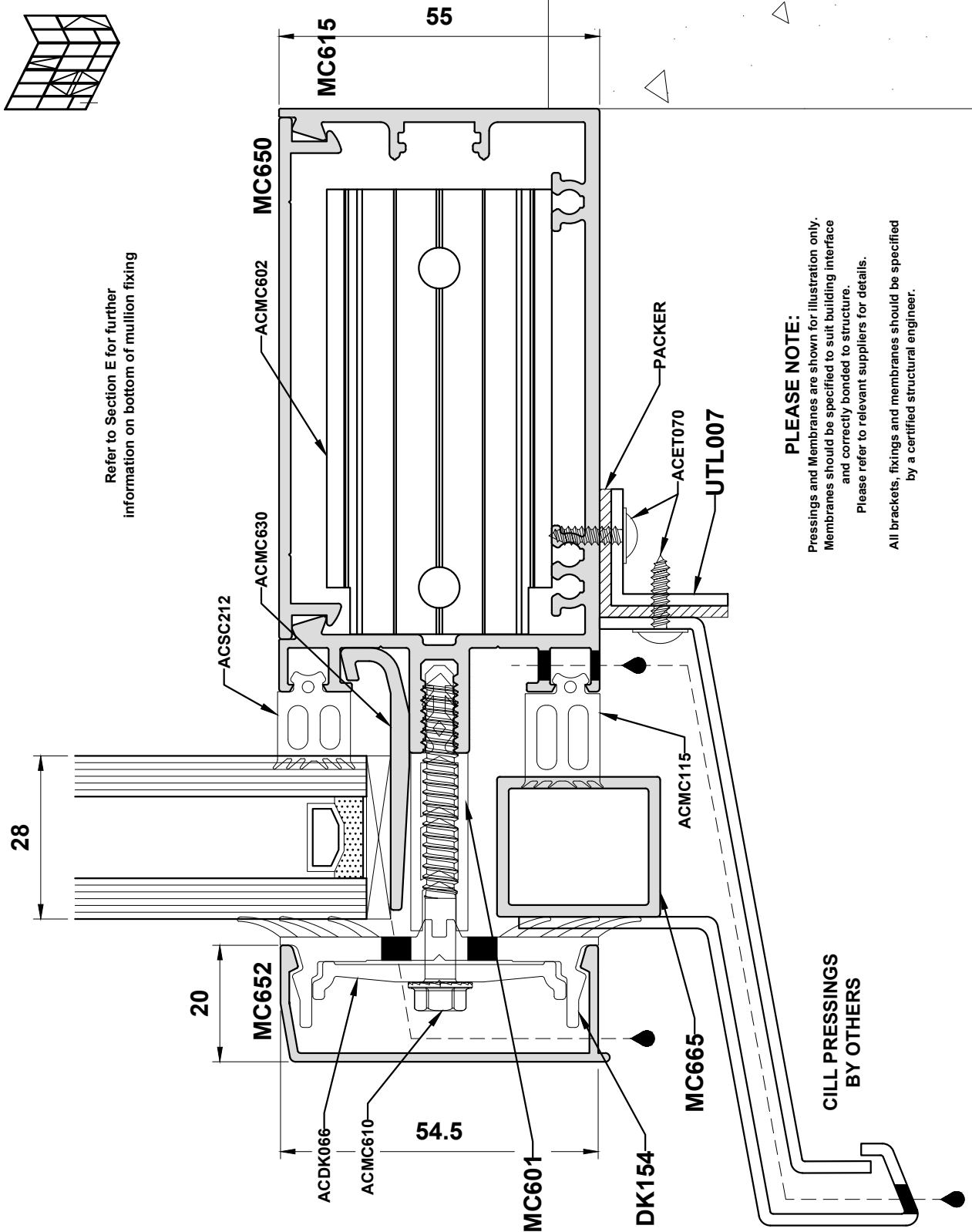


Refer to Section E for further information on bottom of mullion fixing

**PLEASE NOTE:**  
Pressings and Membranes are shown for illustration only. Membranes should be specified to suit building interface and correctly bonded to structure. Please refer to relevant suppliers for details.  
All brackets, fixings and membranes should be specified by a certified structural engineer.

**Do Not Scale From This Drawing**

**Detail 8c - Cill**



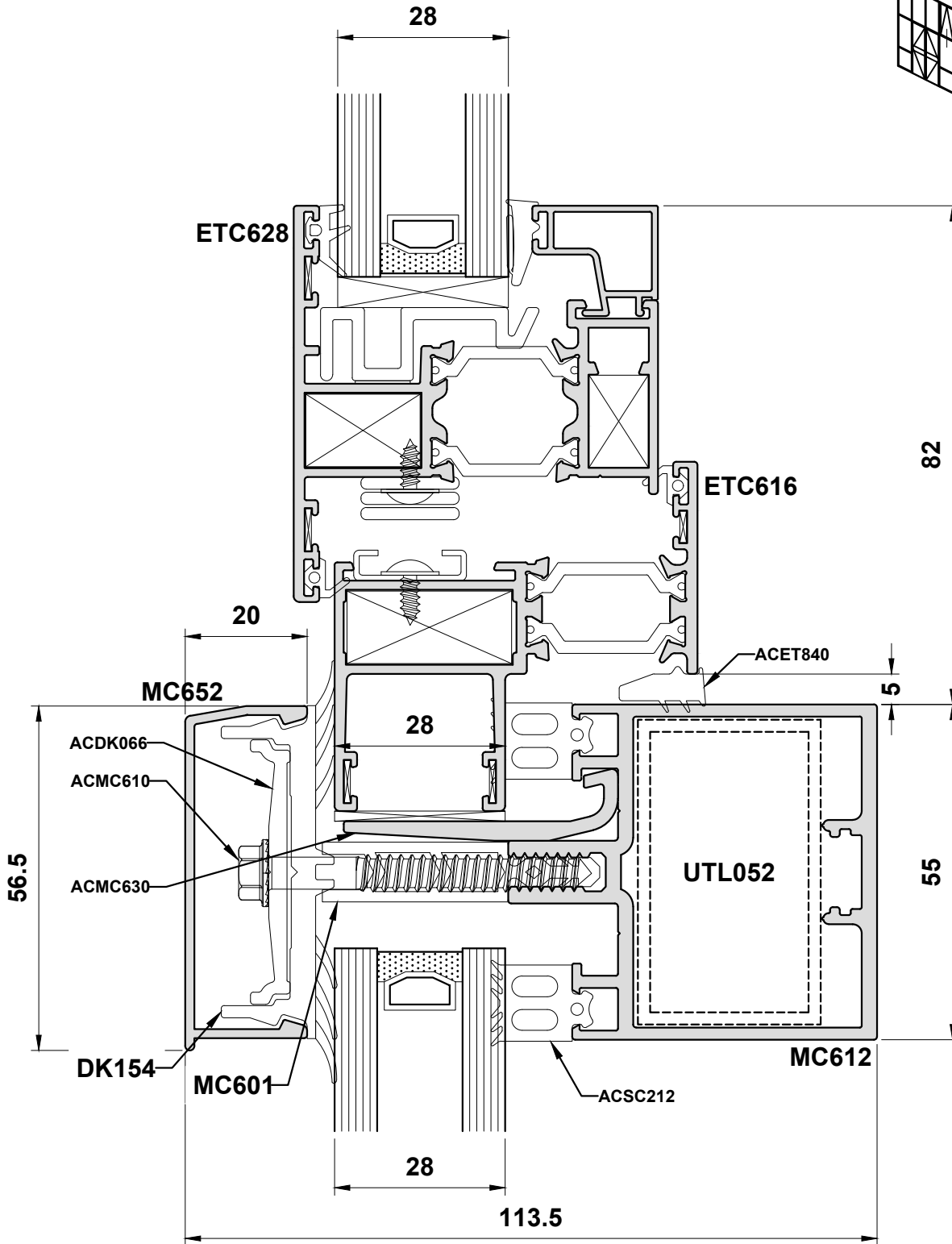
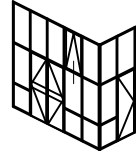
Refer to Section E for further information on bottom of mullion fixing

**PLEASE NOTE:**  
Pressings and Membranes are shown for illustration only.  
Membranes should be specified to suit building interface and correctly bonded to structure.  
Please refer to relevant suppliers for details.  
All brackets, fixings and membranes should be specified by a certified structural engineer.

**CILL PRESSINGS BY OTHERS**

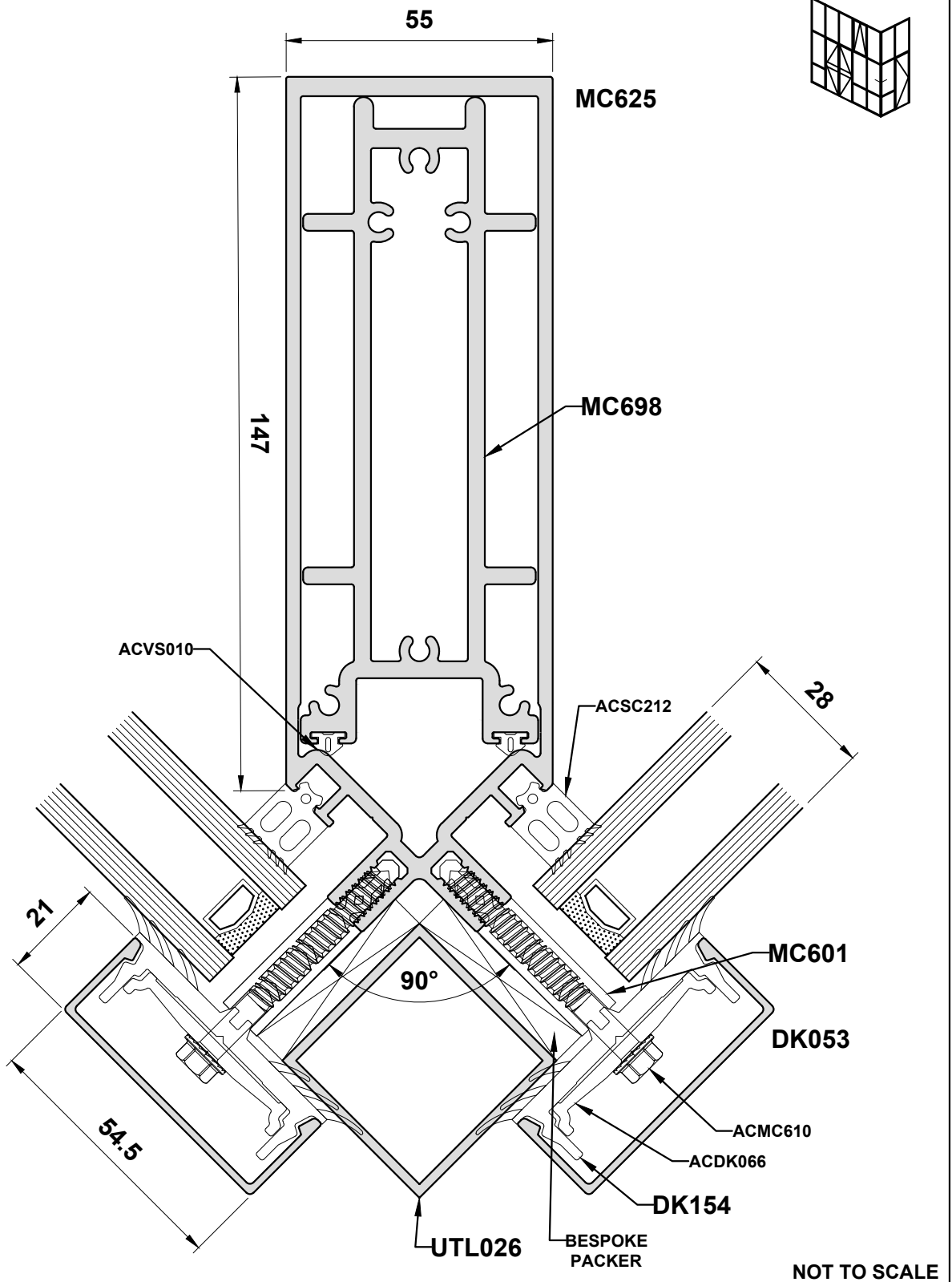
**Do Not Scale From This Drawing**

**Detail 9 - Opening Vent to Transom**



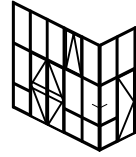
**Do Not Scale From This Drawing**

**Detail 10a - 90° Corner**



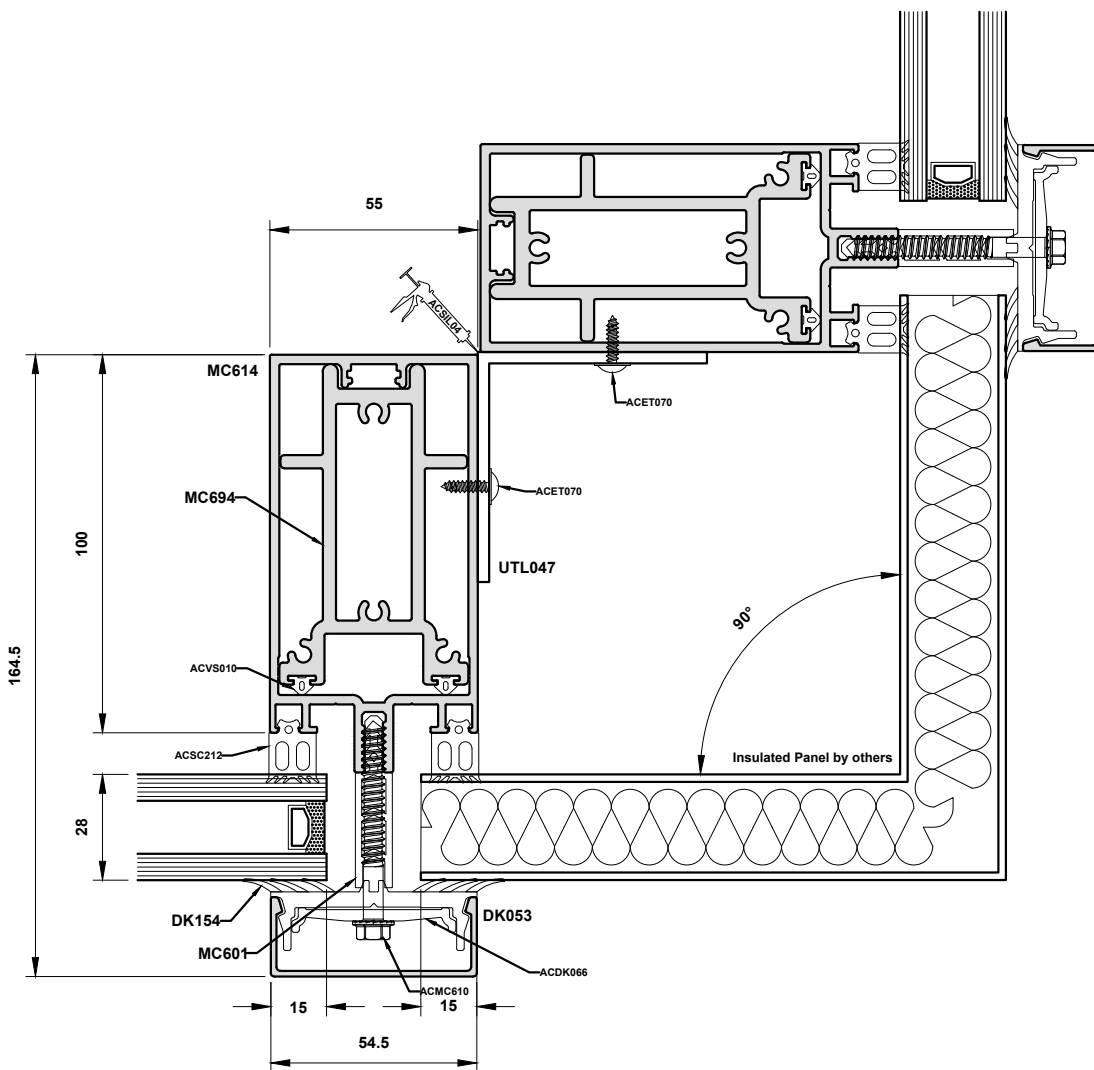
**Do Not Scale From This Drawing**

Detail 10b - 90° Corner



**PLEASE NOTE:**

Brackets and Fixing shown are for illustration only.  
Brackets and Fixings should be specified by a structural engineer.

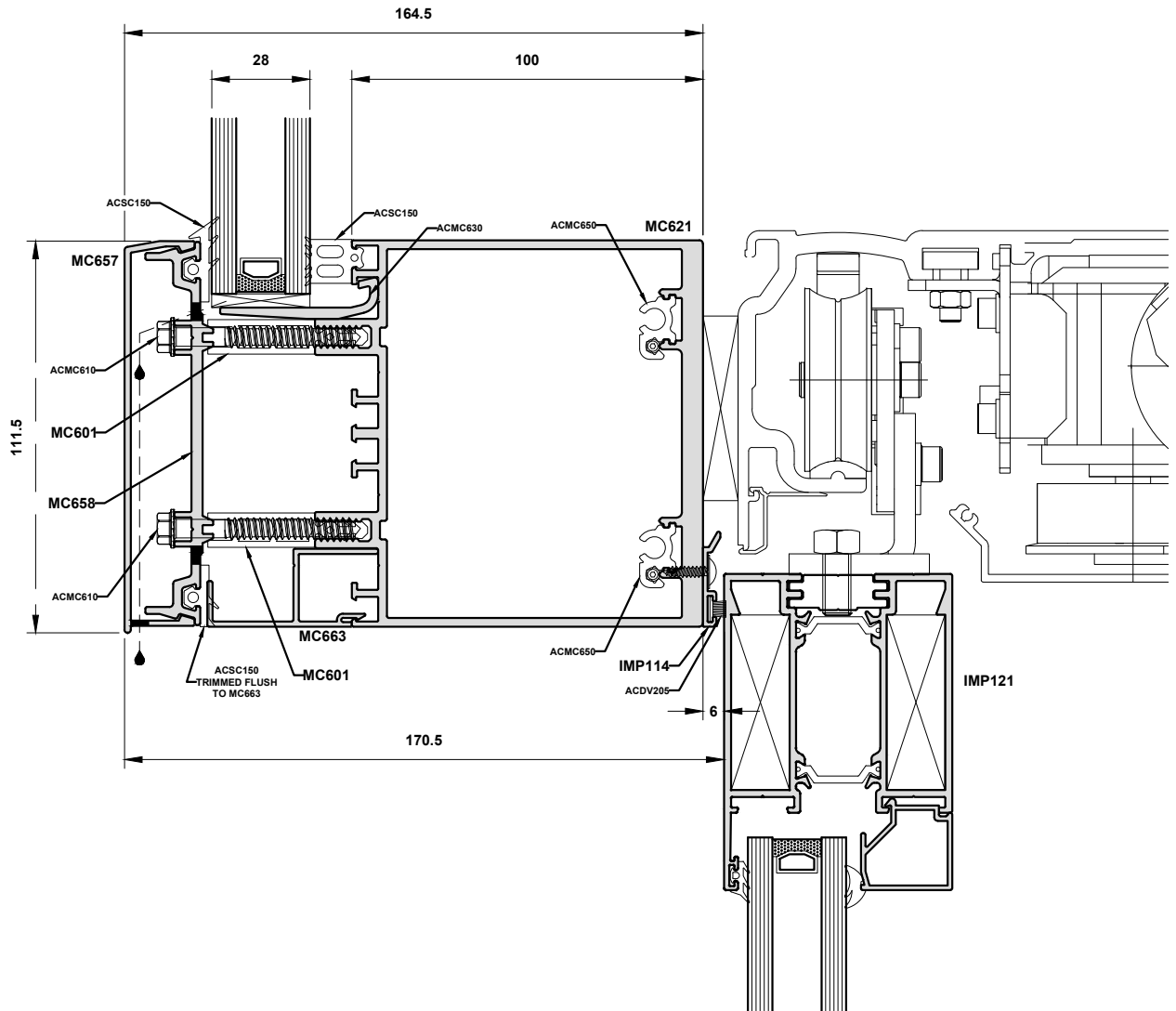
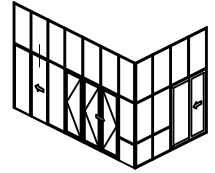


NOT TO SCALE

Do Not Scale From This Drawing



**Detail 11a - Auto Sliding Door Head**

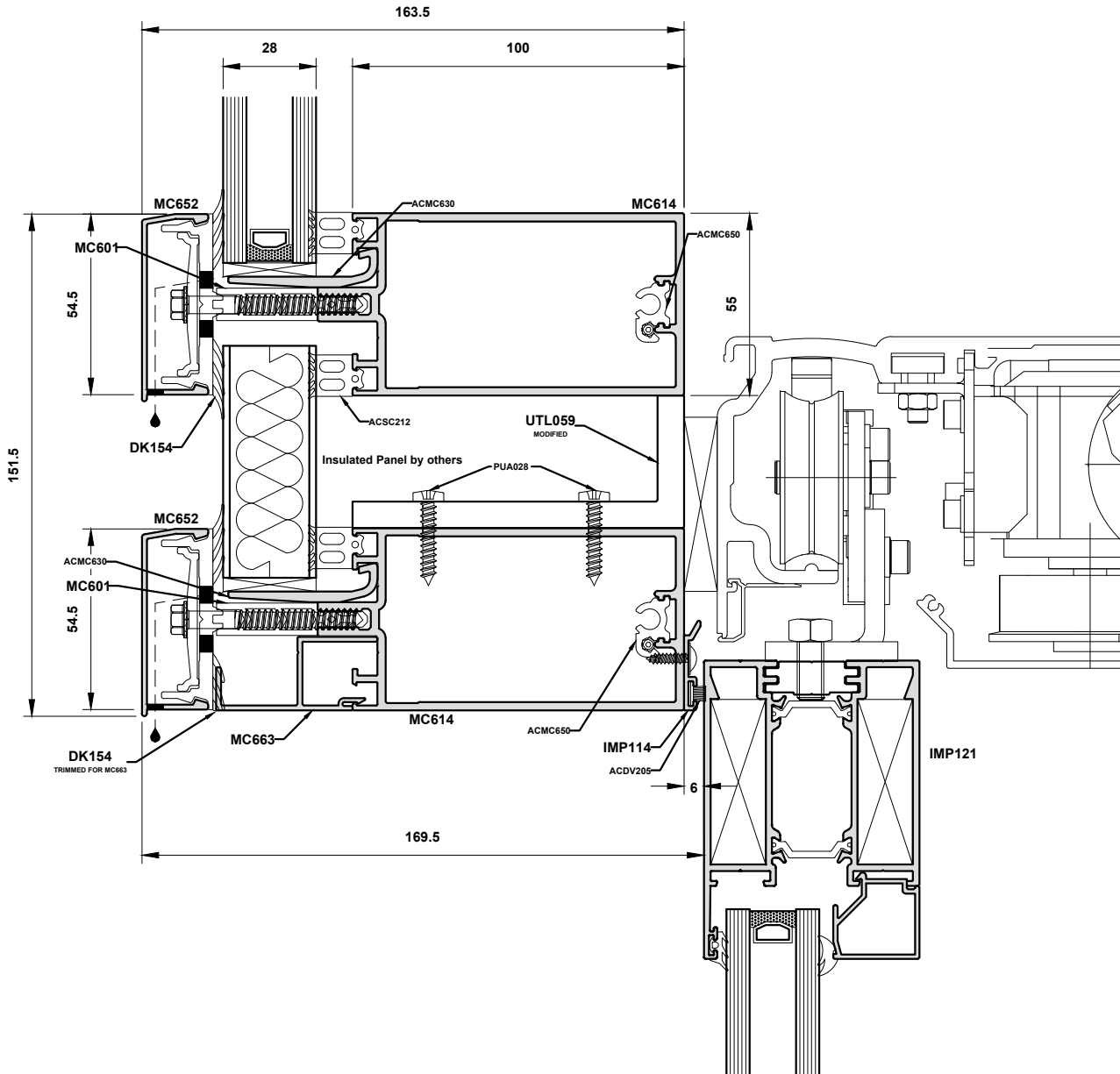
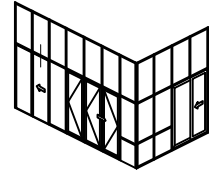


**PLEASE NOTE:**  
For further details on Auto  
Slide Doors, please refer to  
Smart Wall Manual.

**NOT TO SCALE**

**Do Not Scale From This Drawing**

Detail 11b - Auto Sliding Door Head



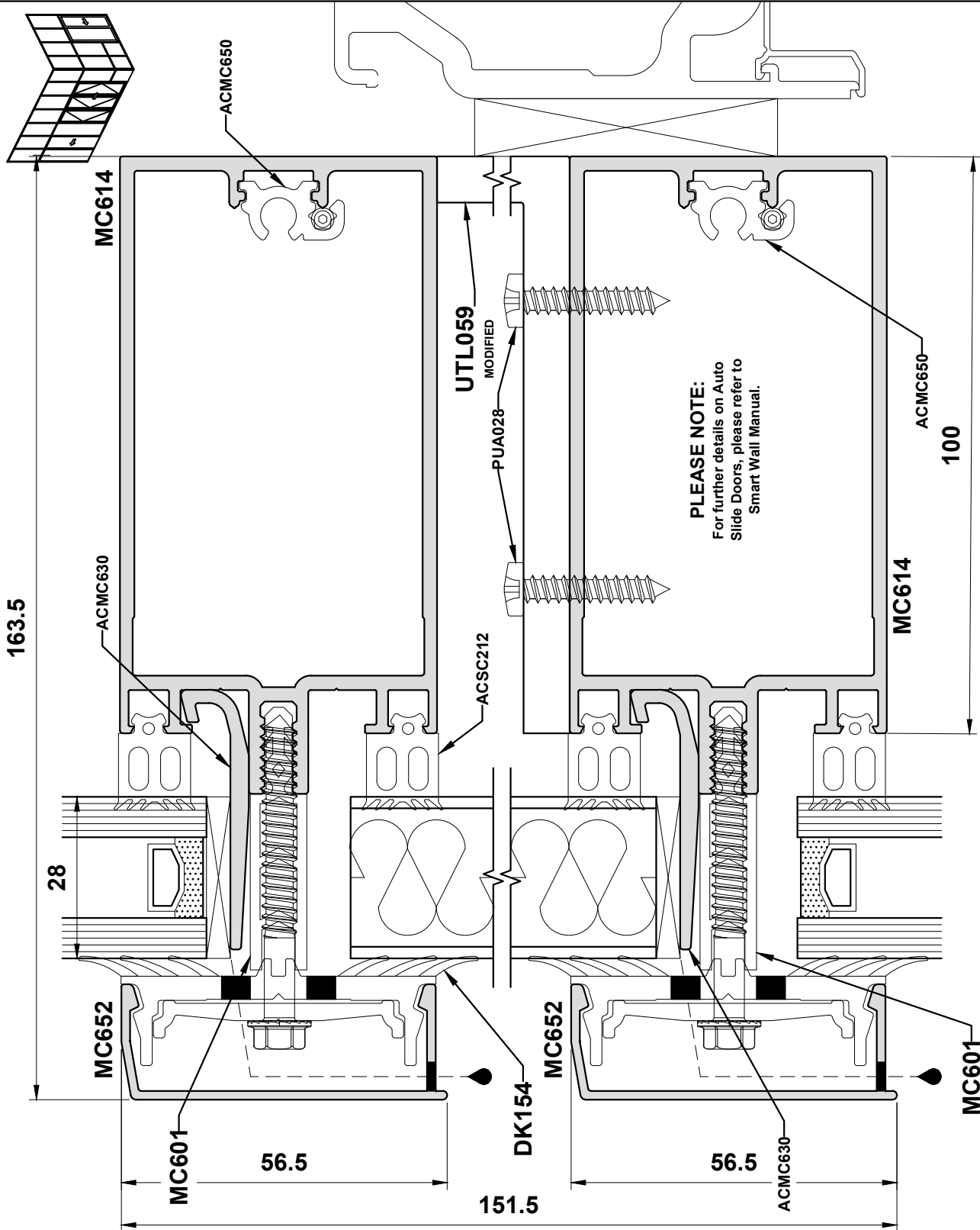
**PLEASE NOTE:**  
For further details on Auto  
Slide Doors, please refer to  
Smart Wall Manual.

NOT TO SCALE

Do Not Scale From This Drawing

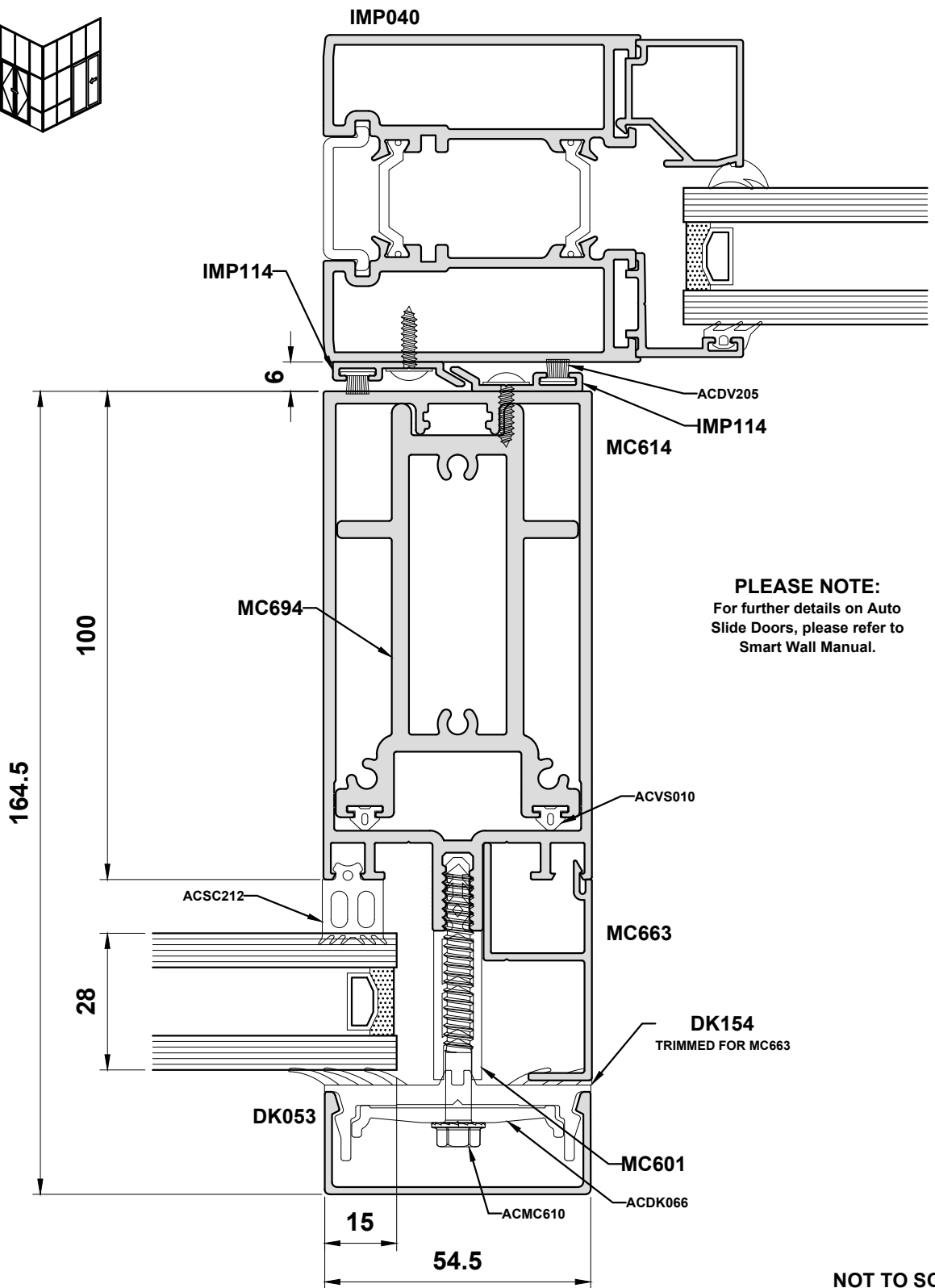
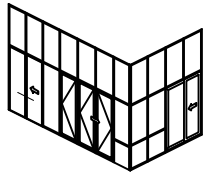


Detail 12b - Auto Sliding Door Head



Do Not Scale From This Drawing

**Detail 13 - Auto Sliding Door Stile**

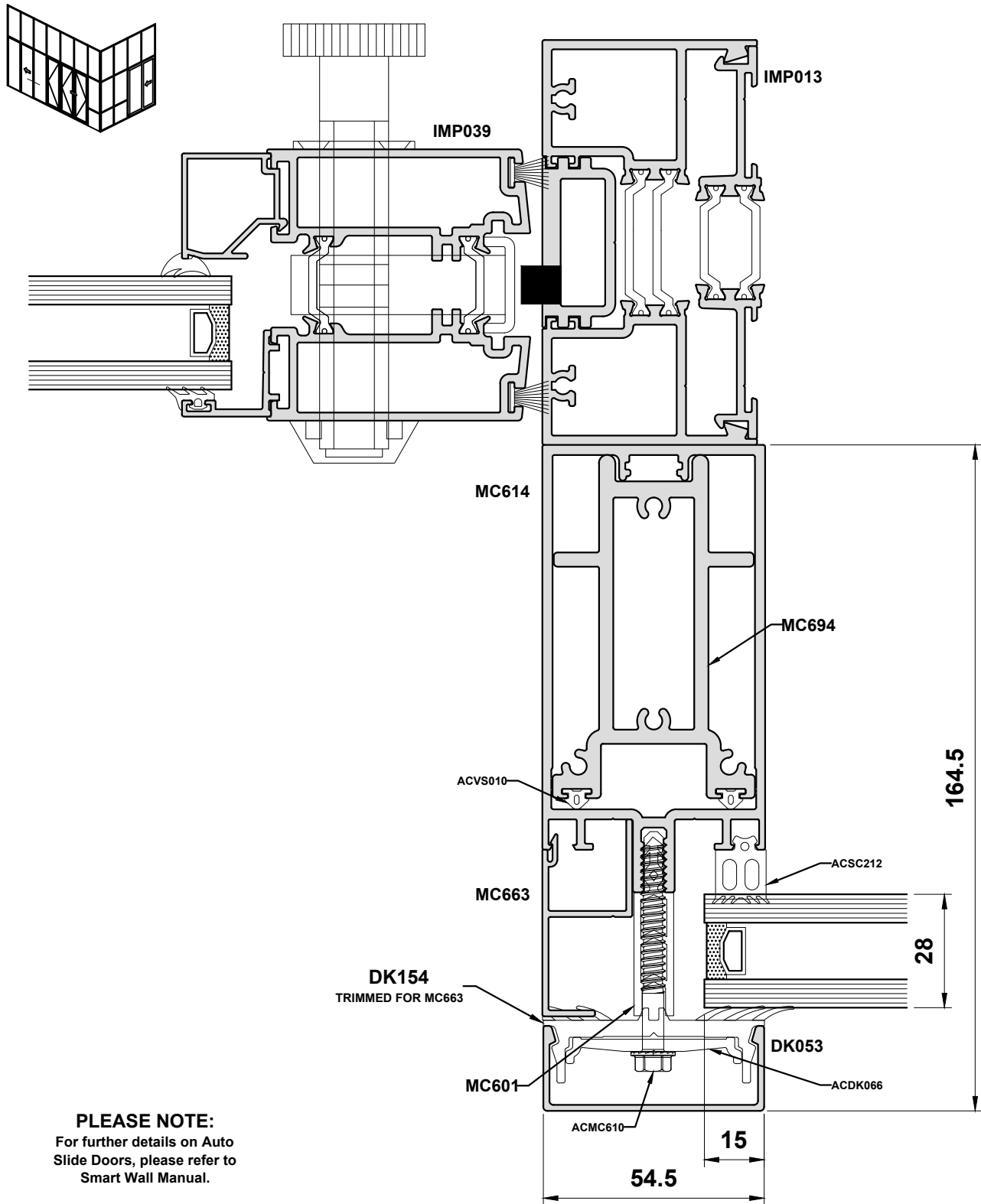


**PLEASE NOTE:**  
For further details on Auto Slide Doors, please refer to Smart Wall Manual.

NOT TO SCALE

**Do Not Scale From This Drawing**

Detail 14 - Auto Sliding Door Stile

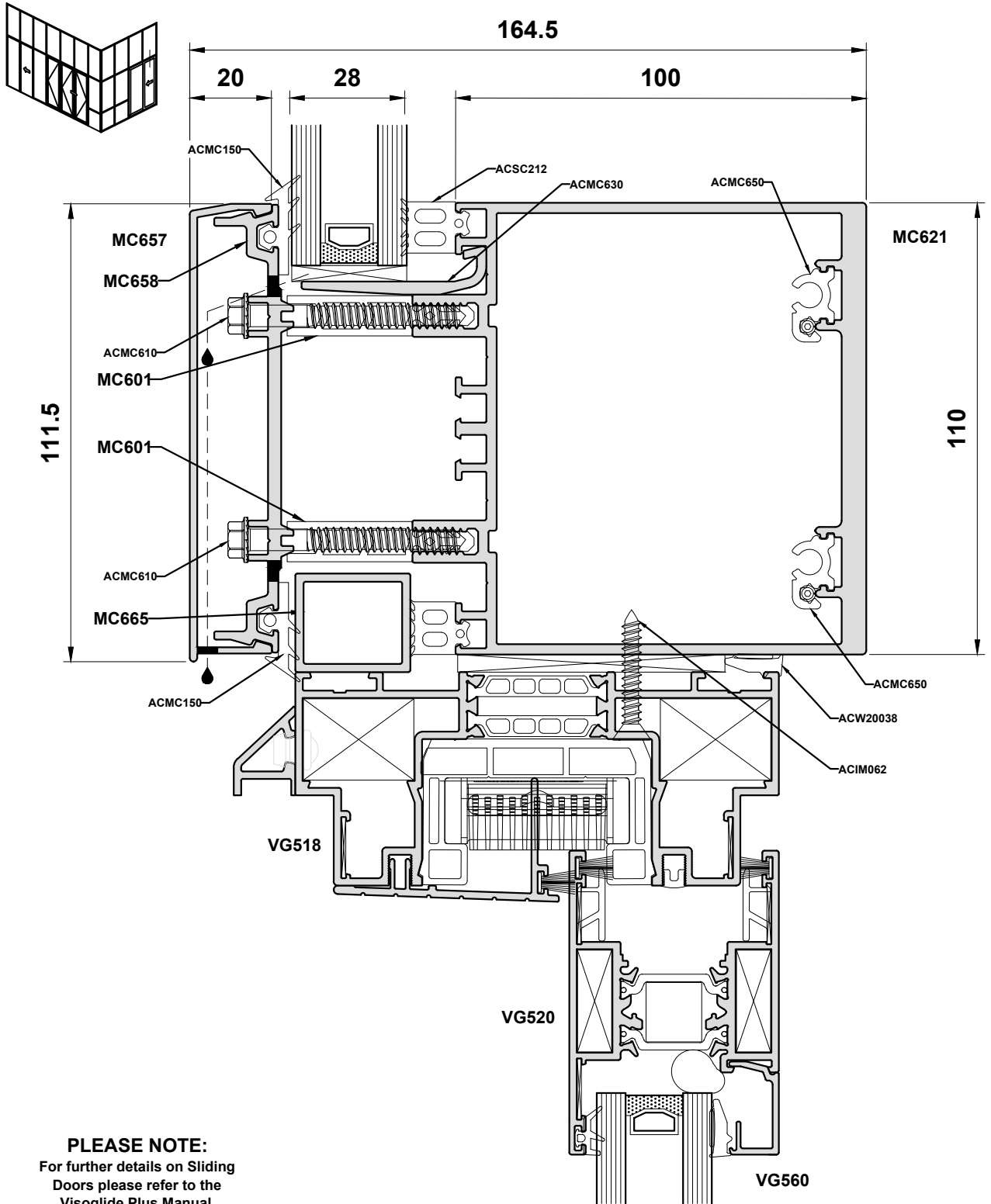


**PLEASE NOTE:**  
For further details on Auto  
Slide Doors, please refer to  
Smart Wall Manual.

NOT TO SCALE

Do Not Scale From This Drawing

**Detail 15 - Visoglide Plus Head**

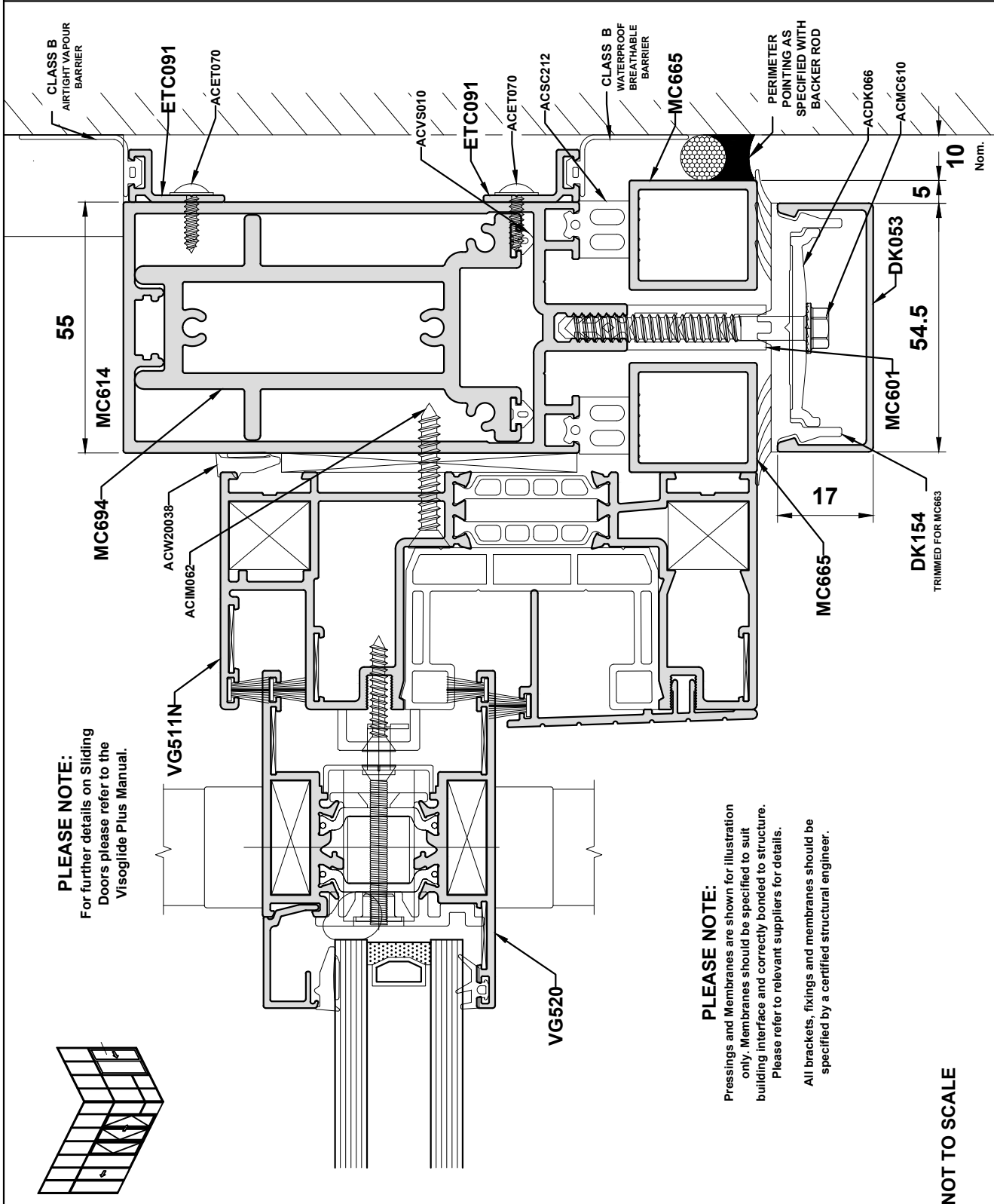


**PLEASE NOTE:**  
For further details on Sliding  
Doors please refer to the  
Visoglide Plus Manual.

**NOT TO SCALE**

**Do Not Scale From This Drawing**

**Detail 16 - Visoglide Plus Jamb**



**PLEASE NOTE:**  
For further details on Sliding Doors please refer to the Visoglide Plus Manual.

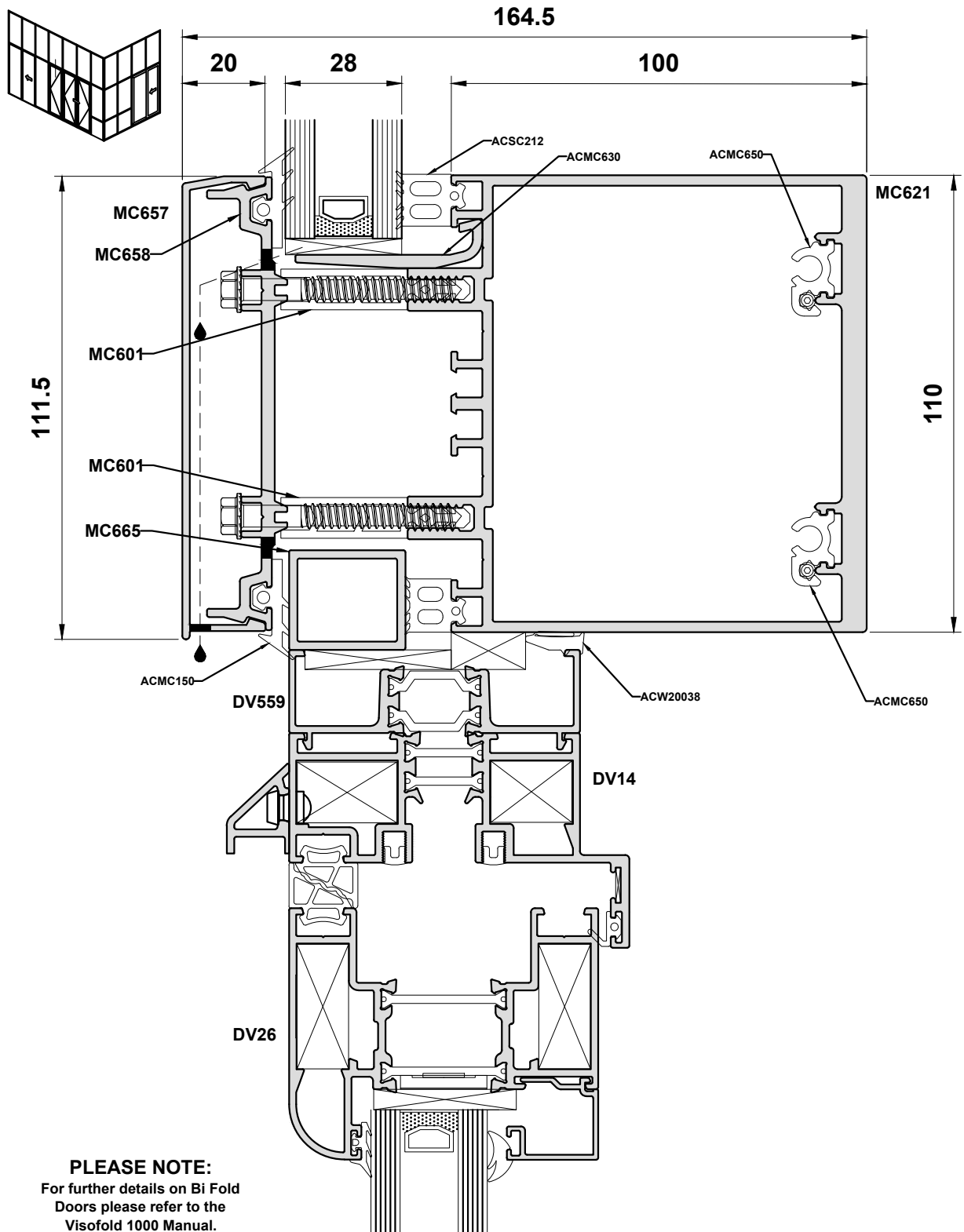
**PLEASE NOTE:**  
Pressings and Membranes are shown for illustration only. Membranes should be specified to suit building interface and correctly bonded to structure. Please refer to relevant suppliers for details.  
All brackets, fixings and membranes should be specified by a certified structural engineer.

**NOT TO SCALE**

**Do Not Scale From This Drawing**



**Detail 17 - Visofold 1000 Head**

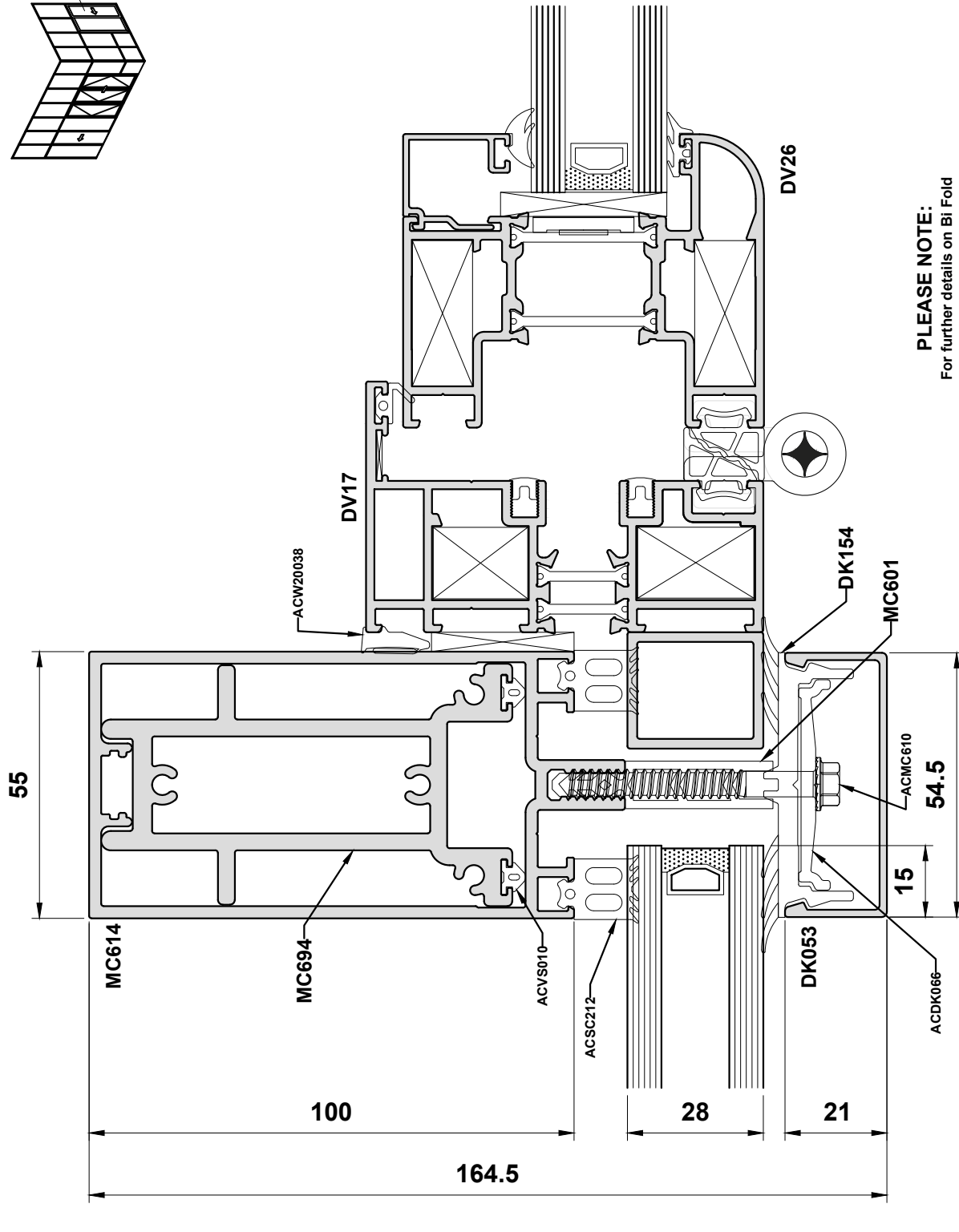
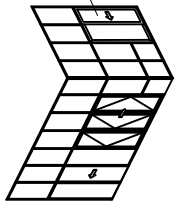


**PLEASE NOTE:**  
For further details on Bi Fold  
Doors please refer to the  
Visofold 1000 Manual.

NOT TO SCALE

**Do Not Scale From This Drawing**

Detail 18 - Visofold 1000 Jamb



**PLEASE NOTE:**  
For further details on Bi Fold  
Doors please refer to the  
Visofold 1000 Manual.

NOT TO SCALE

Do Not Scale From This Drawing

**Section D**

**Statics**

**Open Out & In**

**General Size Limitations are shown on Page A02.**

**For Wind Loading Limitations, Please Contact  
The Technical Department - T: 01934 833100**

THIS PAGE IS INTENTIONALLY LEFT BLANK

## Statics

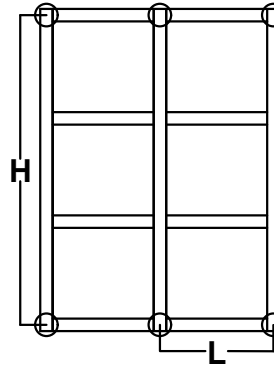
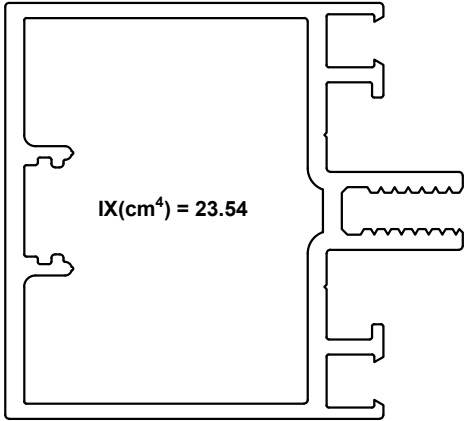
### Important Note

The selection of suitable mullions and transoms should be based on the design wind load of the structure based on criteria including location; exposure; average wind speeds etc. The following pages will assist with the selection of suitable mullions and transoms. For specific details regarding wind loading limitations or further advice, please contact our Technical Department.

**Do Not Scale From This Drawing**

**MC612 Technical Specification**

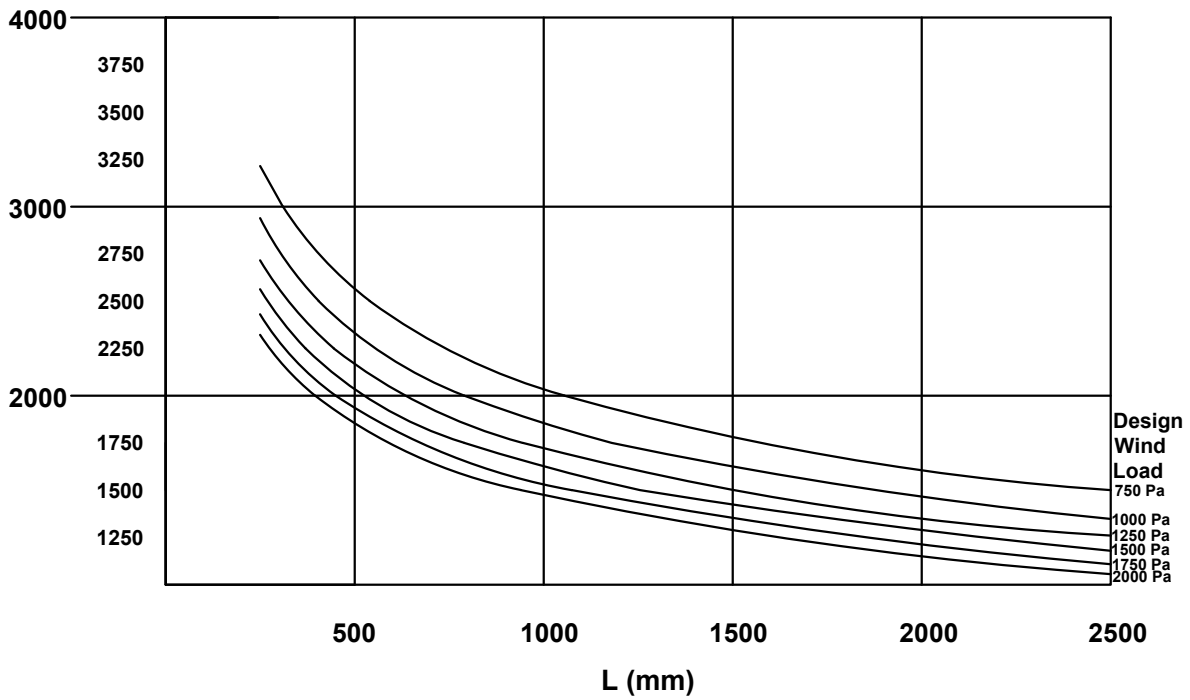
MC612  
Scale 1:1



- = Fixing Bracket
- H = Unsupported Span
- L = Transom Centres

H (mm)

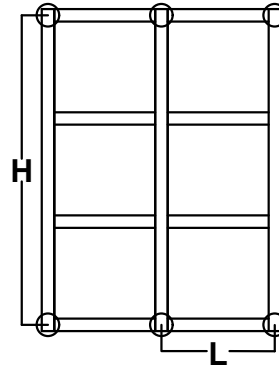
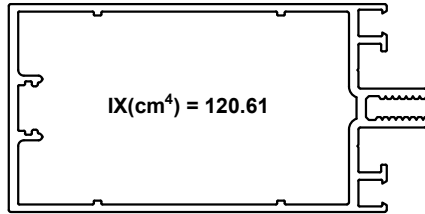
MC612 MC613



**Do Not Scale From This Drawing**

**MC614 Technical Specification**

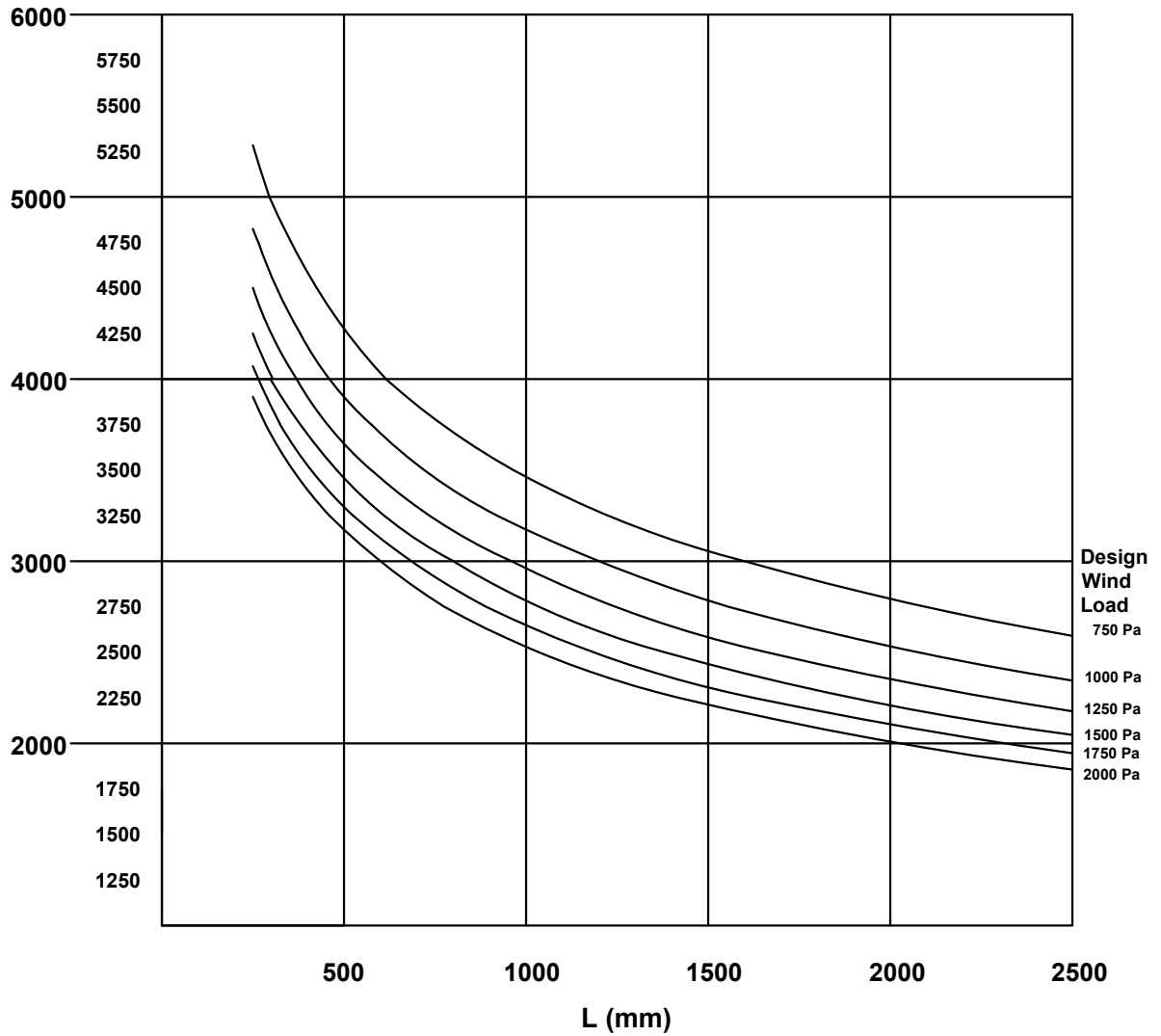
MC614  
Scale 1:2



- = Fixing Bracket
- H = Unsupported Span
- L = Transom Centres

H (mm)

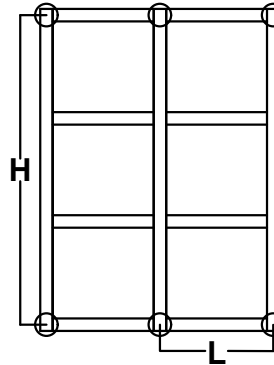
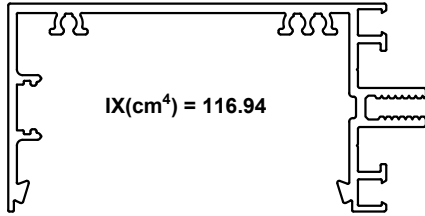
MC614



**Do Not Scale From This Drawing**

**MC615 Technical Specification**

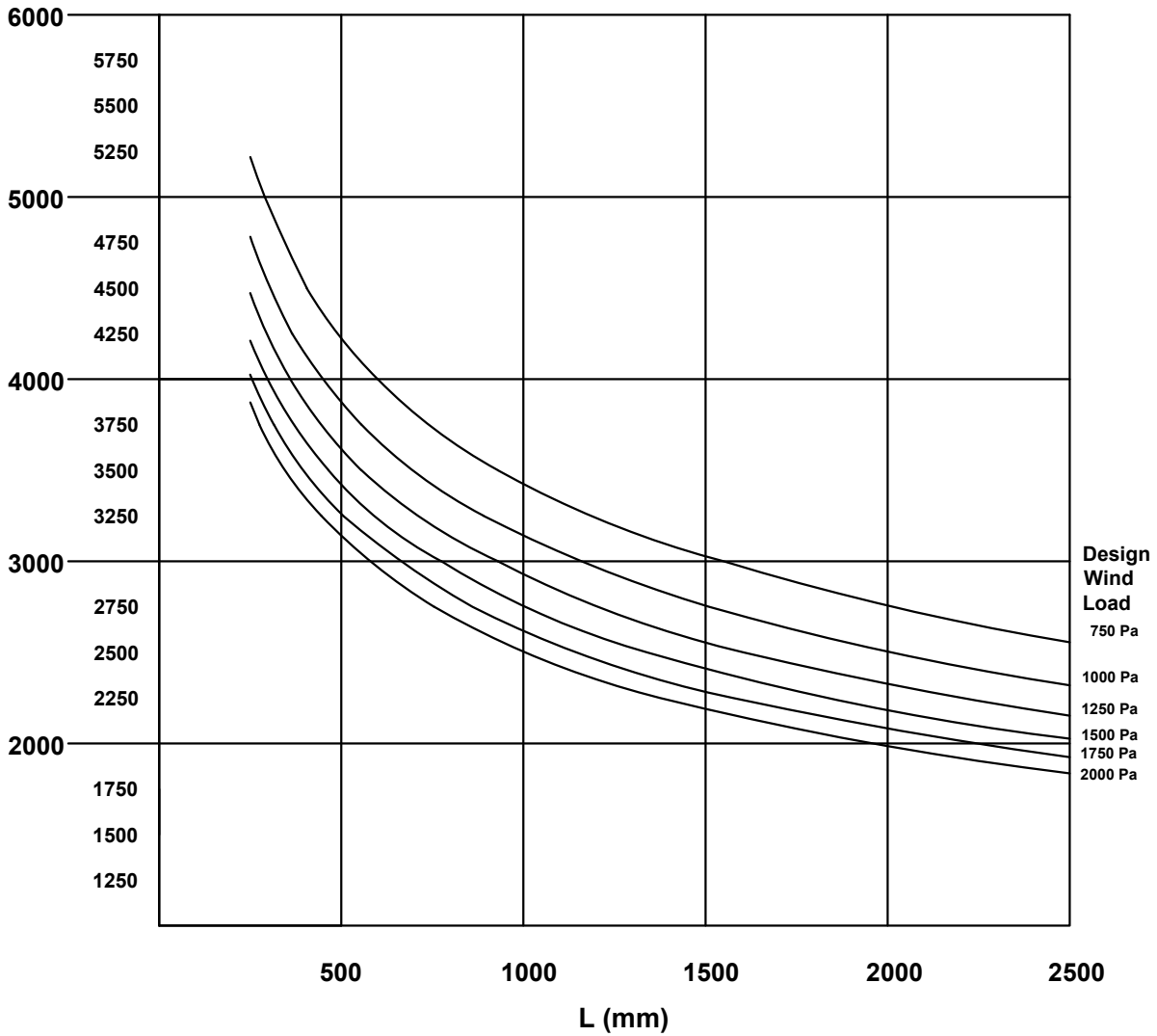
MC615  
Scale 1:2



- = Fixing Bracket
- H = Unsupported Span
- L = Transom Centres

H (mm)

MU615

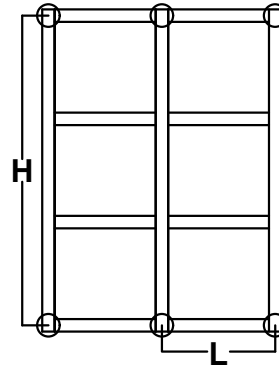
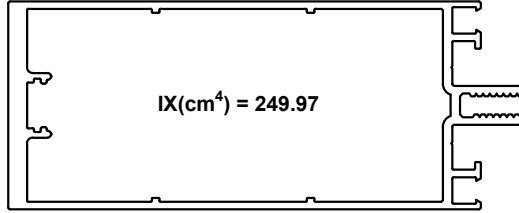


**Do Not Scale From This Drawing**



**MC616 Technical Specification**

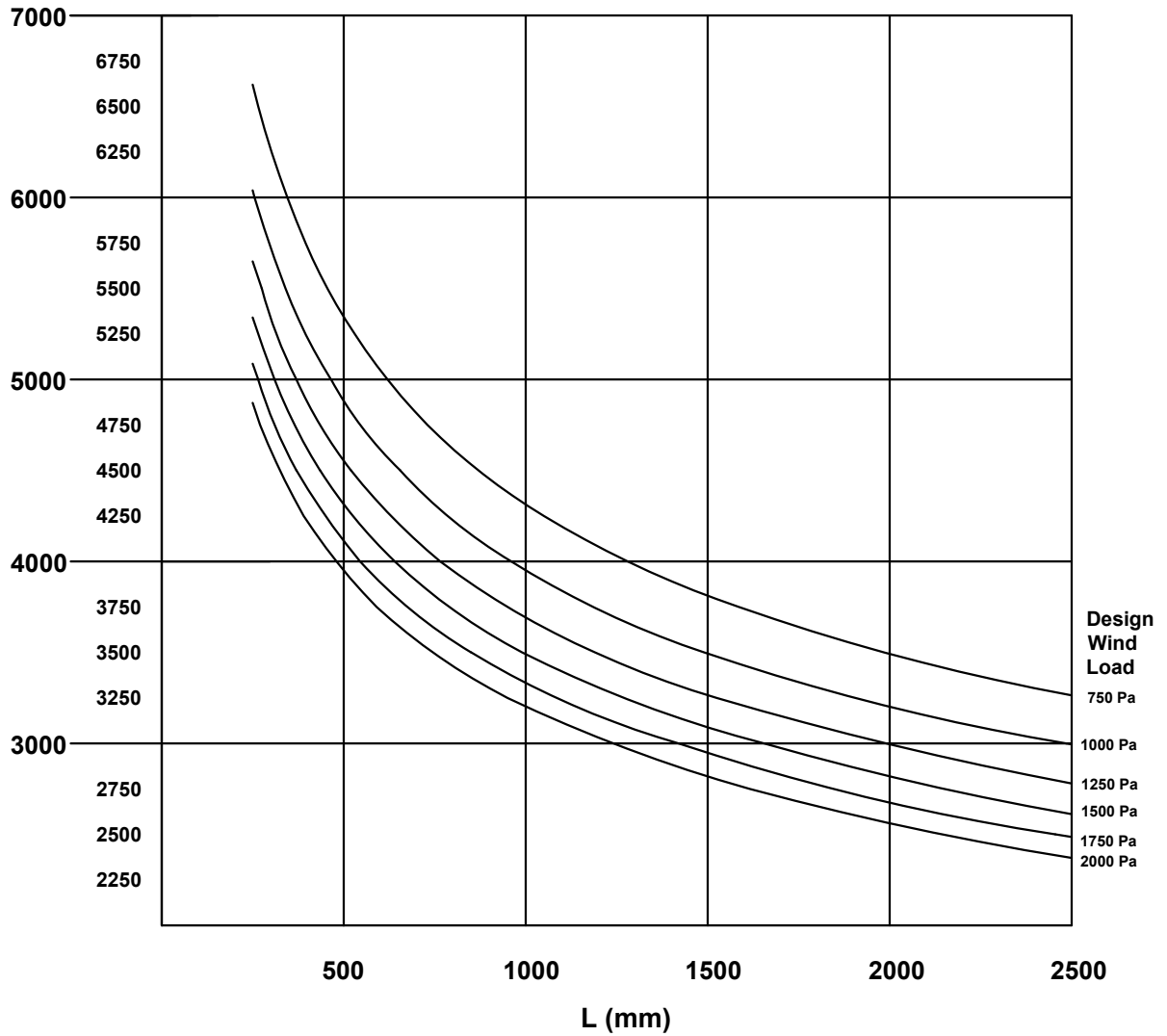
MC616  
Scale 1:2



- = Fixing Bracket
- H = Unsupported Span
- L = Transom Centres

H (mm)

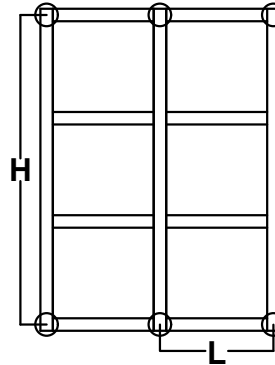
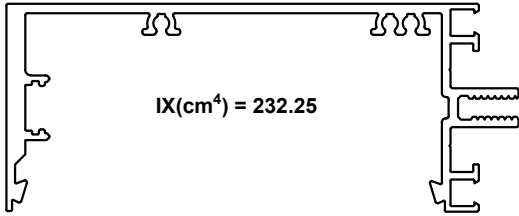
MC616



**Do Not Scale From This Drawing**

**MC617 Technical Specification**

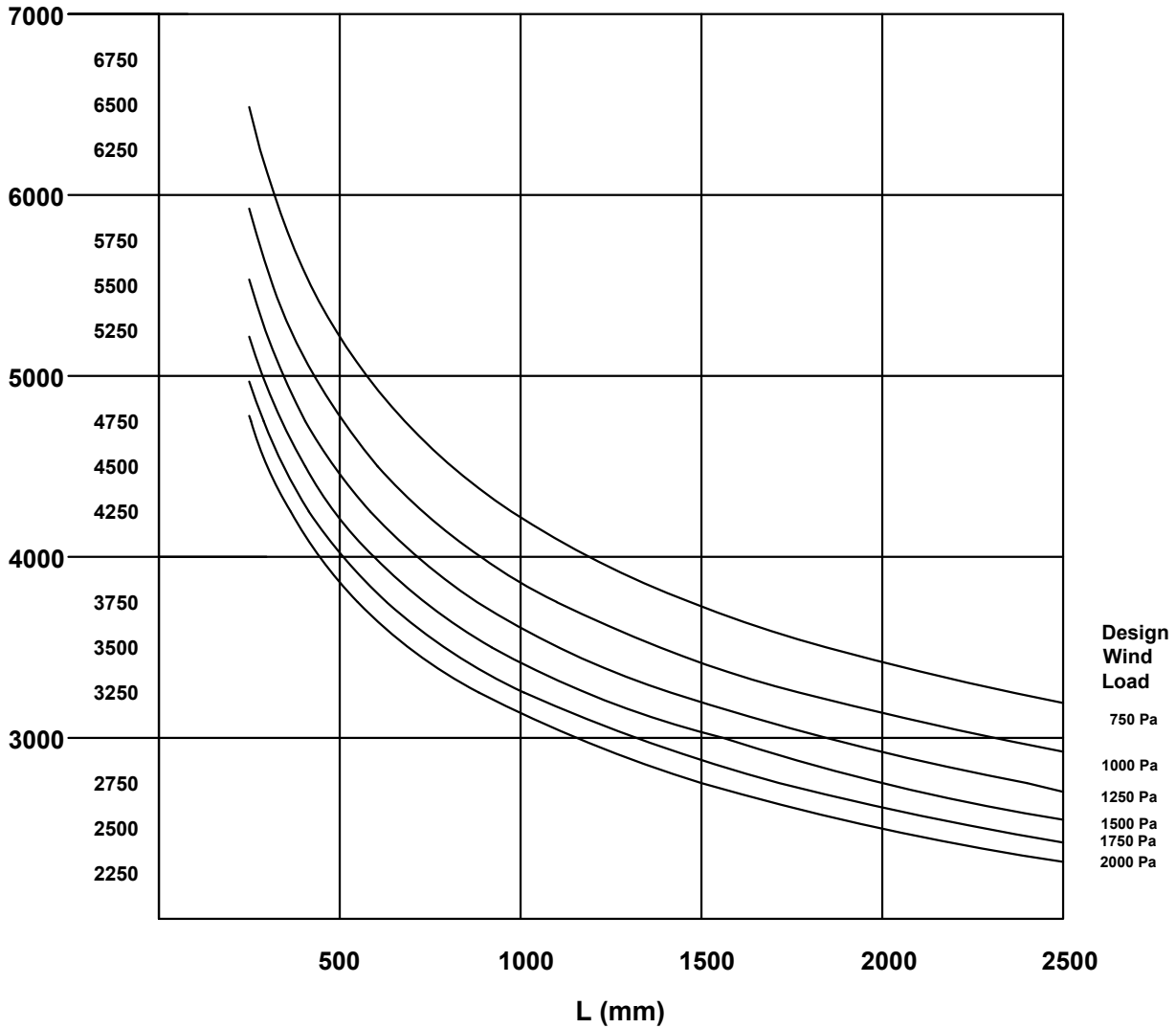
MC617  
Scale 1:2



- = Fixing Bracket
- H = Unsupported Span
- L = Transom Centres

H (mm)

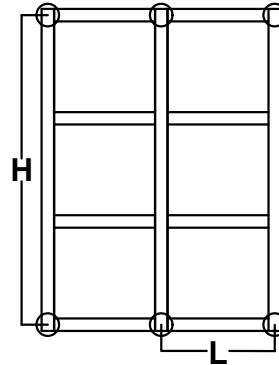
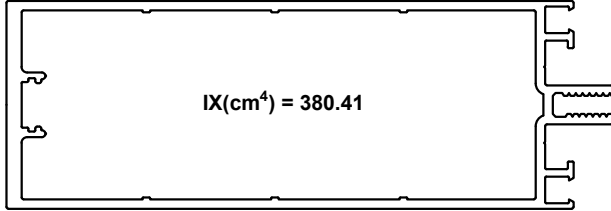
MC617



**Do Not Scale From This Drawing**

**MC618 Technical Specification**

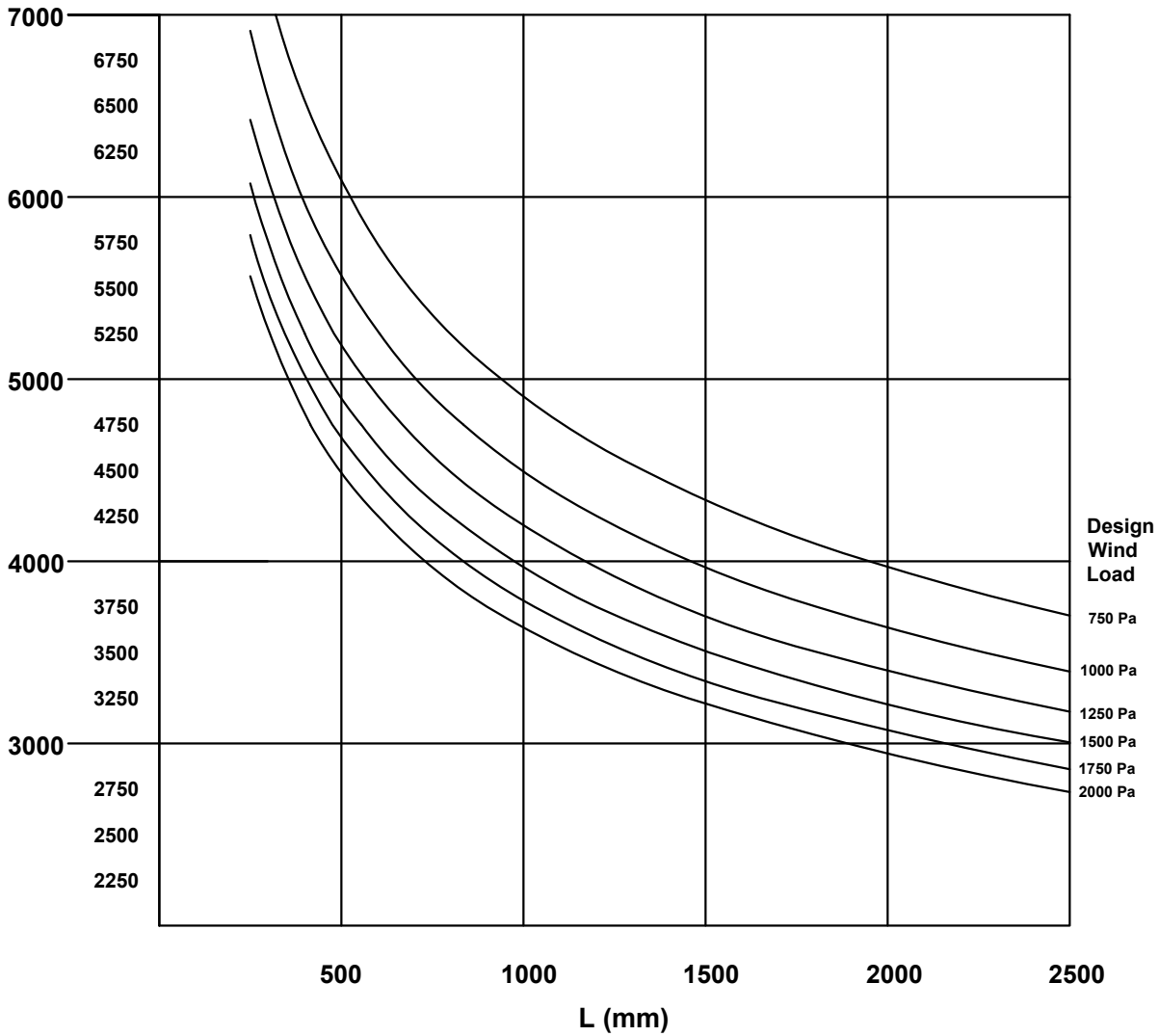
MC618  
Scale 1:2



- = Fixing Bracket
- H = Unsupported Span
- L = Transom Centres

H (mm)

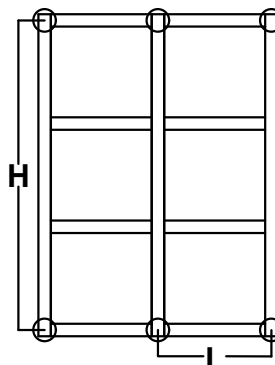
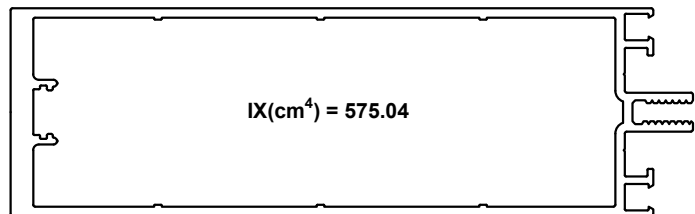
MC618



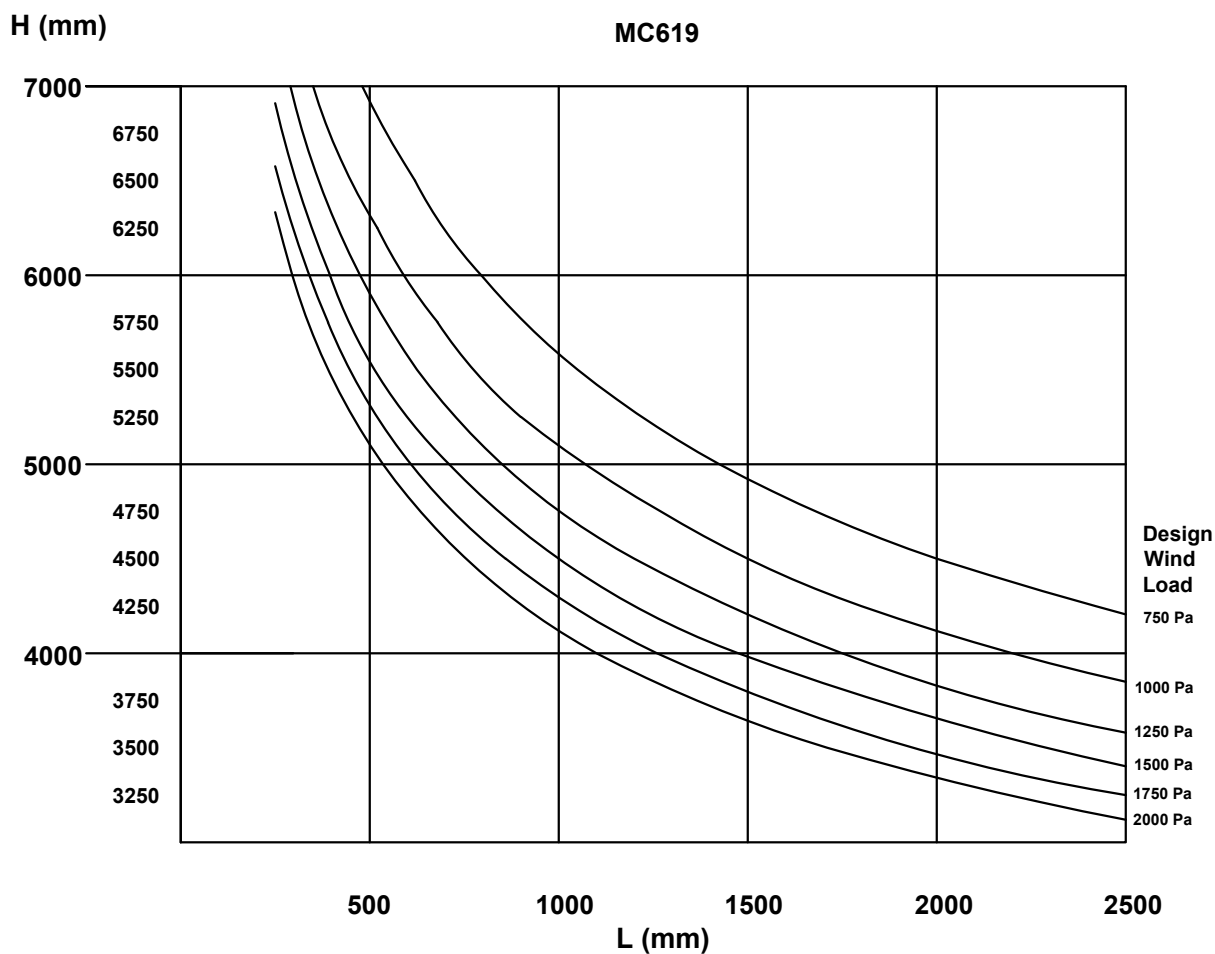
**Do Not Scale From This Drawing**

## MC619 Technical Specification

MC619  
Scale 1:2



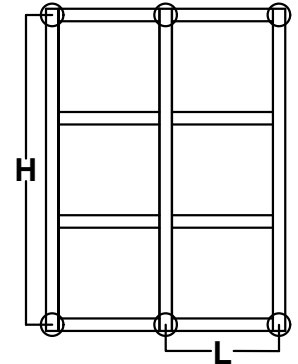
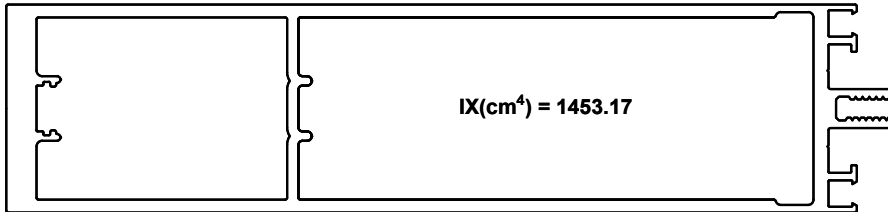
- = Fixing Bracket
- H = Unsupported Span
- L = Transom Centres



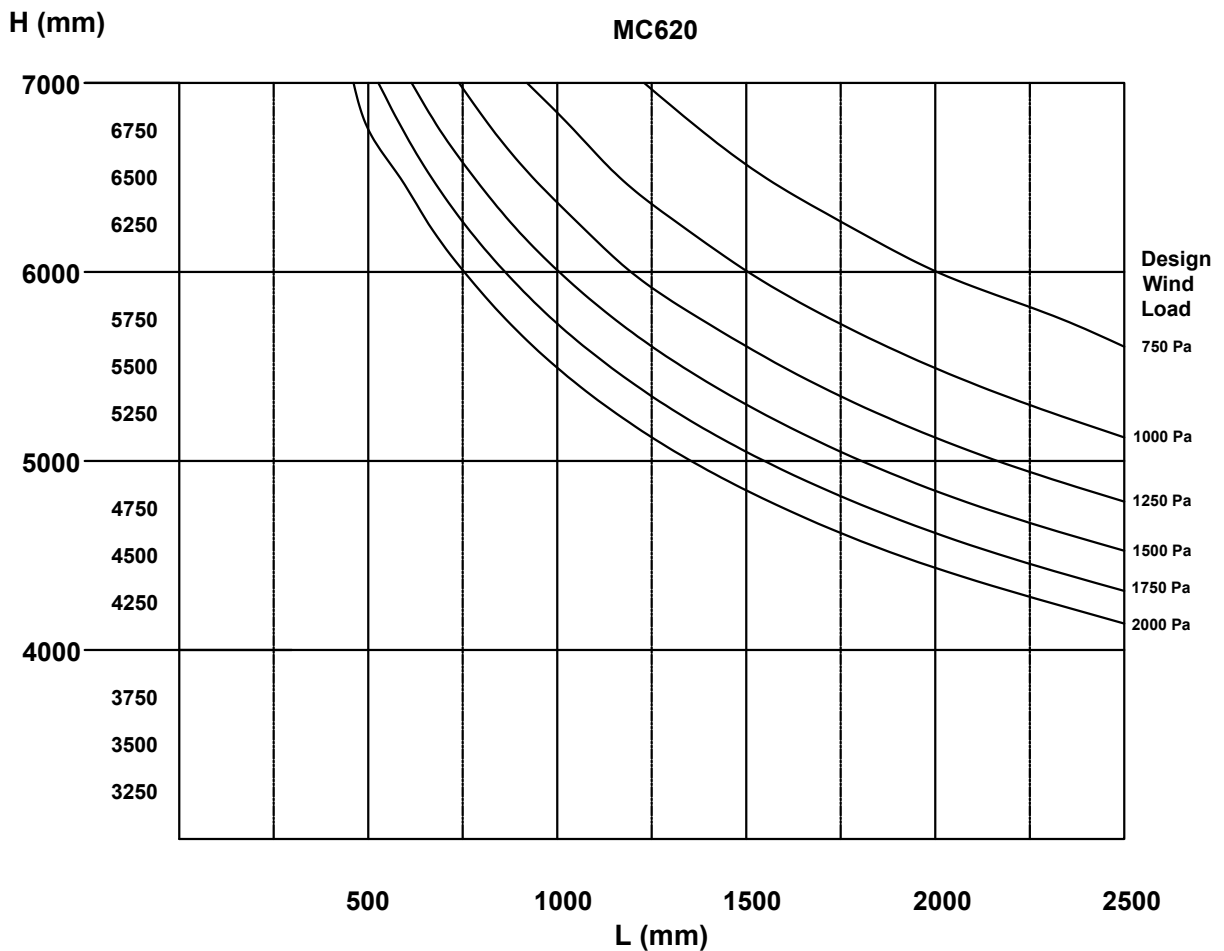
**Do Not Scale From This Drawing**

**MC620 Technical Specification**

MC620  
Scale 1:2



- = Fixing Bracket
- H = Unsupported Span
- L = Transom Centres



**Do Not Scale From This Drawing**

THIS PAGE IS INTENTIONALLY LEFT BLANK

**Section E**



Construction Drawings - Open Out

NHBC Notice.....	E03
Bracket Requirements.....	E04
Horizontal Deductions.....	E05
Stick Build Mullion Preparation - ACMC650.....	E06
Stick Build Transom Preparation.....	E07
Stick Build Assembly - ACMC650 Spring Pin.....	E08 - E09
Ladder Build Assembly - Shear Block.....	E10
Drainage & Pressure Equalisation.....	E11
Reinforcing Sleeves.....	E12
Splice Joints.....	E13
Transom / Mullion Sealing.....	E14
Sleeves.....	E15
Mullion on Transom Preparation.....	E16
Mullion on Transom Assembly.....	E17
Raked Head.....	E18
Glazing Details.....	E19

THIS PAGE IS INTENTIONALLY LEFT BLANK



**NHBC**

Before undertaking any Curtain Wall job, please refer to:

**NHBC - Curtain Walling & Cladding - Chapter 6.9**

Please note both CWCT and NHBC consider all storey height glazing to be a curtain wall and therefore should be designed as such. Curtain walling cannot be treated in the same way as window and door installations.

**The following are requirements in undertaking a Curtain Walling project:**

- Full elevation drawings must be produced. These drawings should clearly indicate all perimeter interface details typically showing water / vapour barriers, pressings / trims, fixing brackets / fixings along with any fire stopping that may be required. This is not an exhaustive list as other details may be required to suit specific projects.
- All bracketry and fixings should be backed up by calculations from a structural engineer to confirm suitability and meet site requirements. Also, profiles need to be identified to suit site conditions. These factors include screen sizes, fixing positions, glass weight, barrier loadings & wind loadings.
- It may be a requirement to include for on-site water testing and pull out testing. NHBC would require certification to the CWCT weather test where glazing may span a floor as opposed to a BS6375-1 window / door weather test.

Please also consider acoustic, thermal and structural performance when specifying curtain wall configuration and components.

**It would be expected that one or more members of installation teams have been certified by the Systems supplier to demonstrate competence and understanding of the system being installed.**

**IF IN DOUBT - CONTACT TECHNICAL DEPARTMENT:**



**01934 876 100**  
**stechnical@smartsystems.co.uk**



**The latest NHBC documentation can be found at:**

*<https://nhbc-standards.co.uk/6-superstructure-excluding-roofs/6-9-curtain-walling-and-cladding/>*

**Do Not Scale From This Drawing**

## Bracket Requirements

### Structural Curtain Wall Brackets

Brackets form the link between the curtain wall and the structure. These are critically important to the safety and serviceability of the wall.

Brackets need to be designed to transfer all the loads from the curtain wall to the structure safely, whilst accommodate tolerances and movement. The screen will depend on the availability of a suitable support structure (tie back positions).

The loads will vary on the size of the screen and the location of the building. Brackets need to be designed to interface with a suitable support structure/building frame. Detail drawings will be required to identify the location and position of any brackets.

#### Dead loads - Support

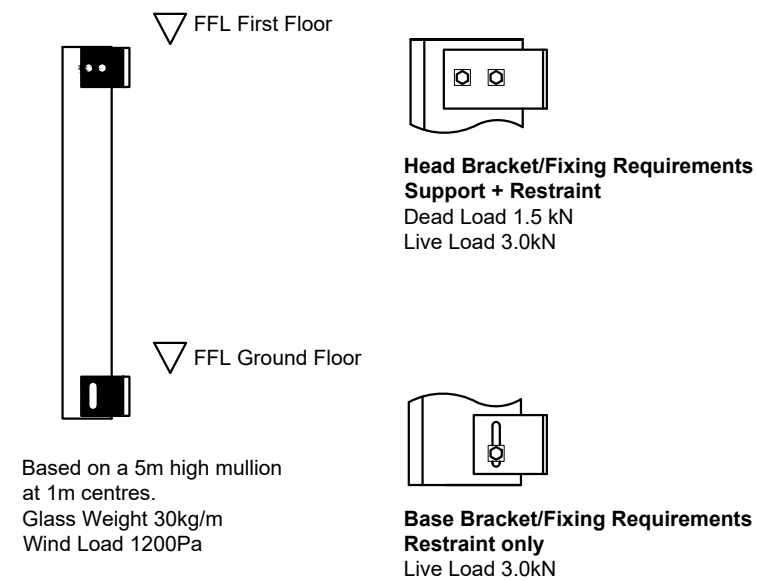
The weight of the curtain wall needs to be transferred to the structure.

#### Live Loads - Restraint

Wind loads in the form of negative (suction) or positive pressures are usually the dominant load case.

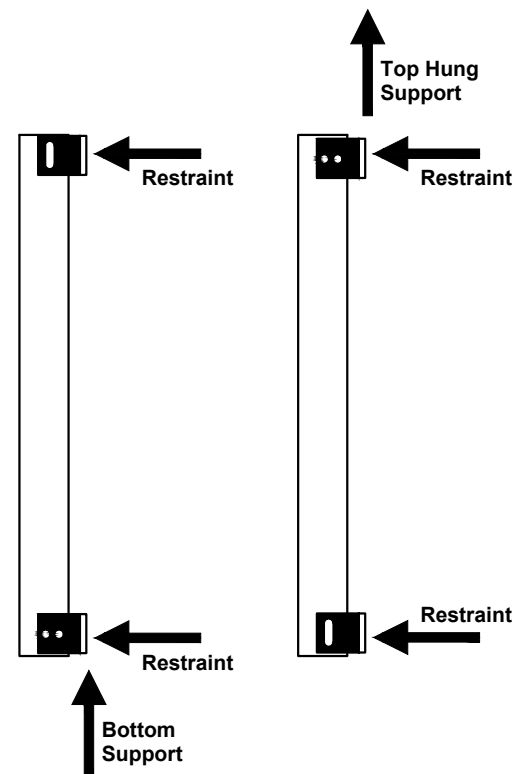
Brackets and fixings on curtain wall are structural and must be designed to relevant structural codes.  
BS8118. Structural Use of Aluminium

### Typical Load Requirements



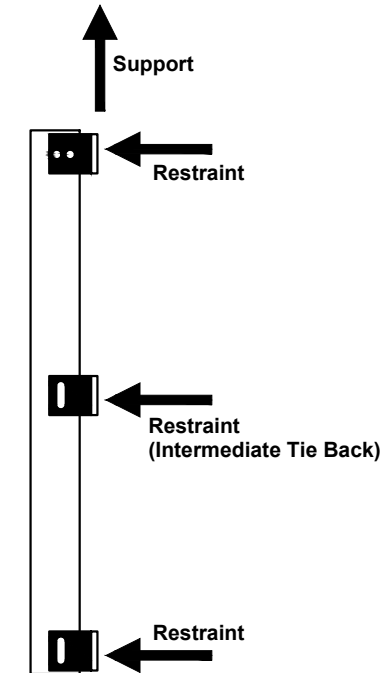
### Single Span

For single span there are two possible arrangements of these fixings for a single storey mullion. The top hung arrangement is more common but the bottom supported arrangement may be used, particularly for low rise construction.



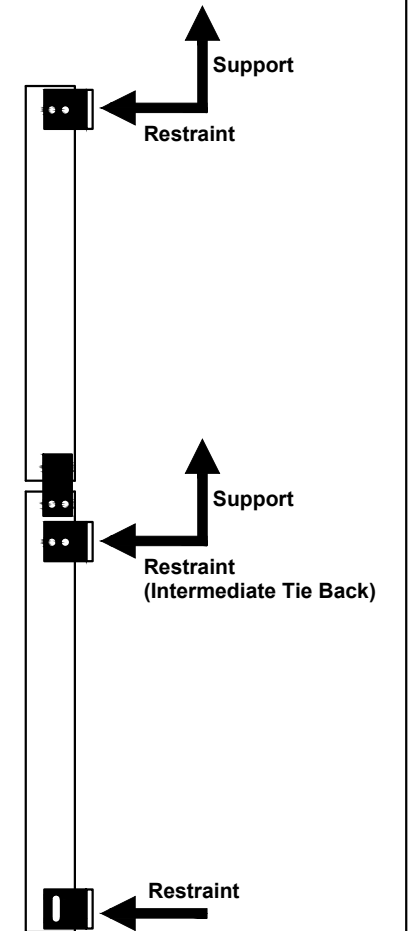
### Multiple Tie Back

Where mullions span more than one storey, restraint fixings are usually provided at intermediate floors. By providing mid point tie back restraints the required mullion strength may be reduced.



### Multiple Span

Where mullions span more than one mullion length (typically 7m). A Splice Joint will be required to join mullions. Each length will require one support fixing for dead load transfer.

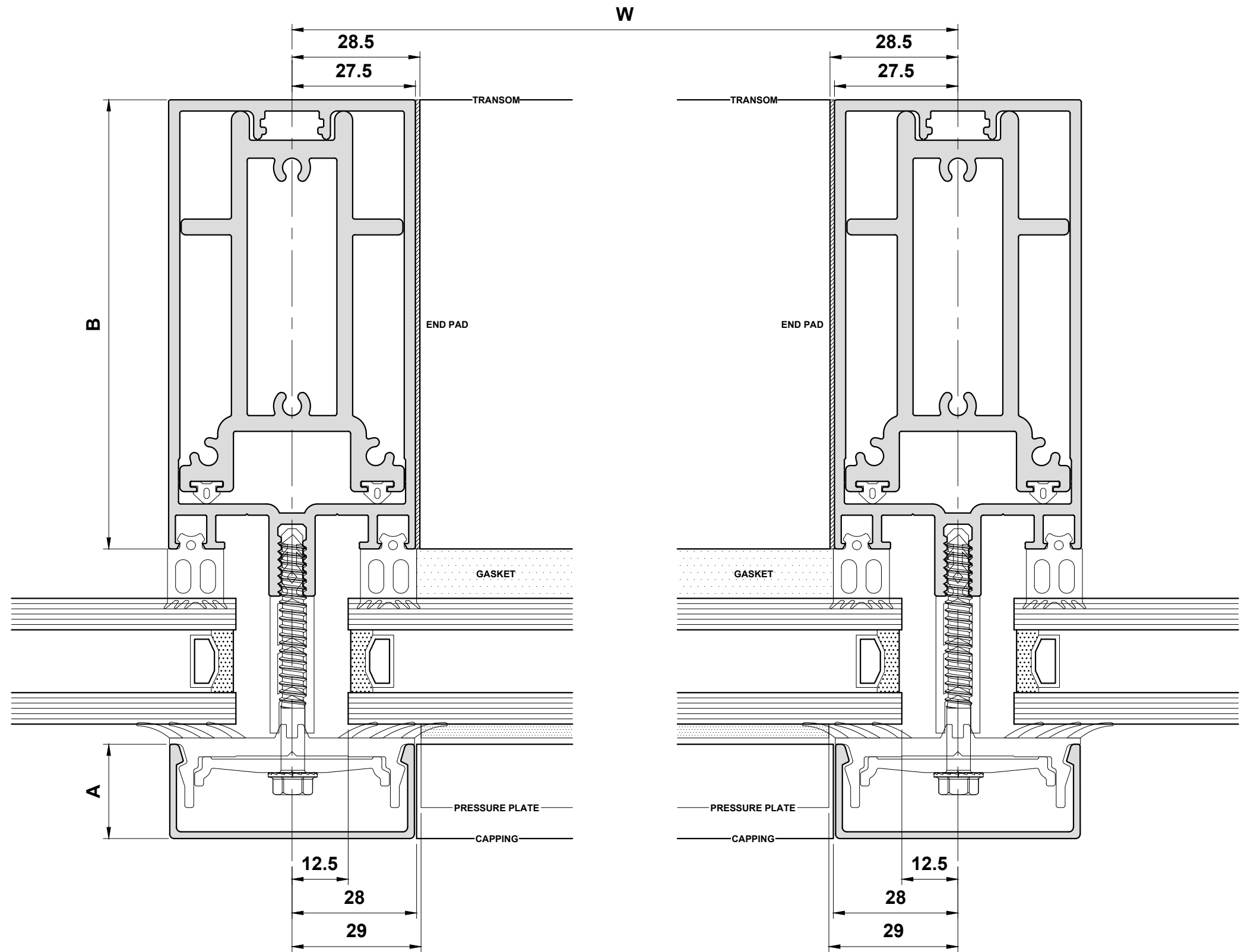
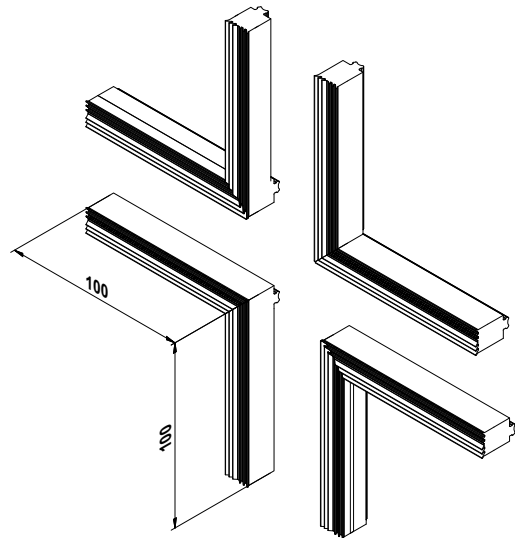


Do Not Scale From This Drawing

Horizontal Deductions

Horizontal Deductions	
Component	Formula
Glass	W - 25
Capping	W - 56
Pressure Plate	W - 58
Transom without End Pads*	W - 55
Transom with End Pads	W - 57
Isolator without Transom End Pads	W - 55
Isolator with Transom End Pads	W - 57
Gasket	W - 255

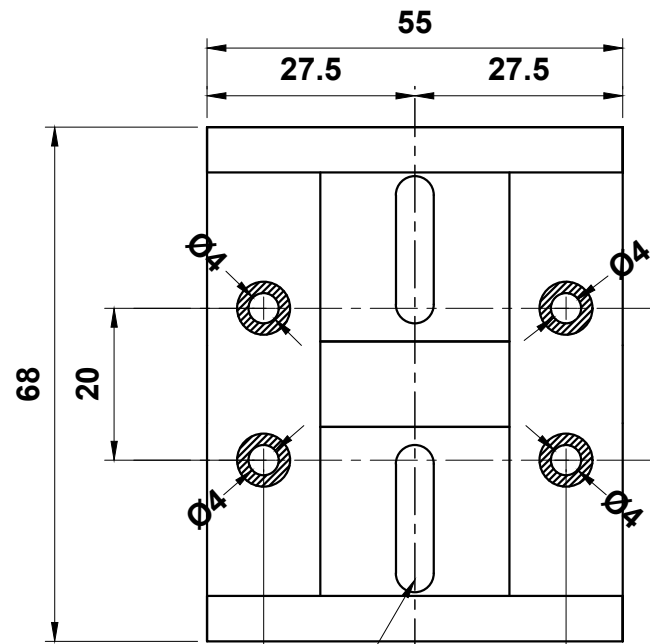
\*PLEASE NOTE: OPEN BOX TRANSOMS DO NOT HAVE TRANSOM END PADS



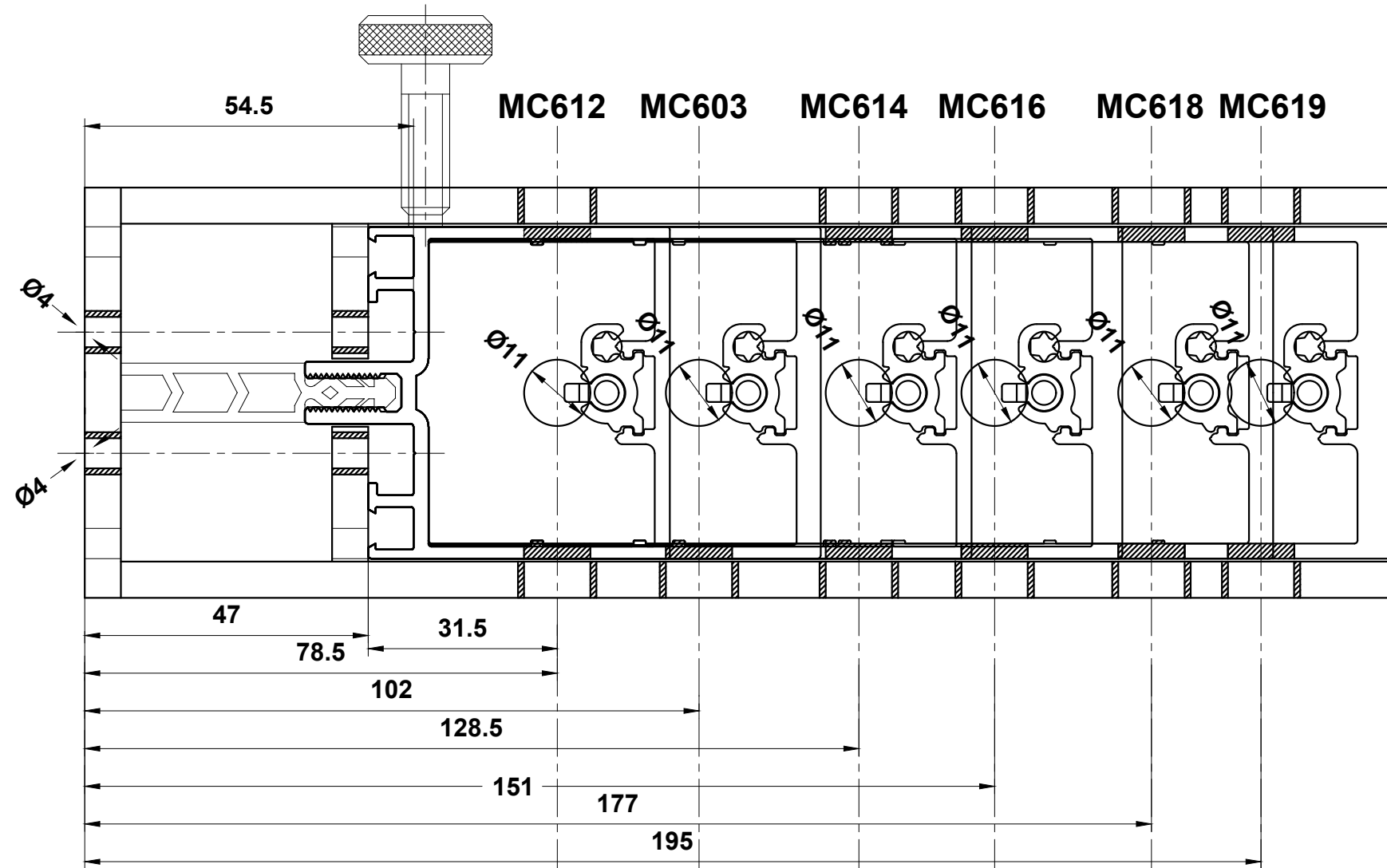
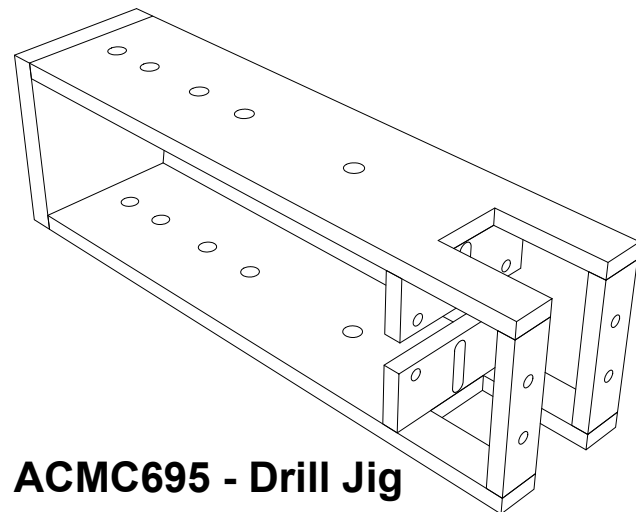
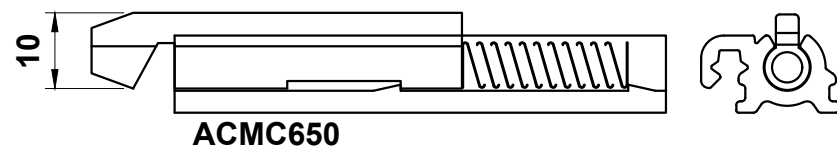
Do Not Scale From This Drawing

Stick Build Mullion Preparation - ACMC650

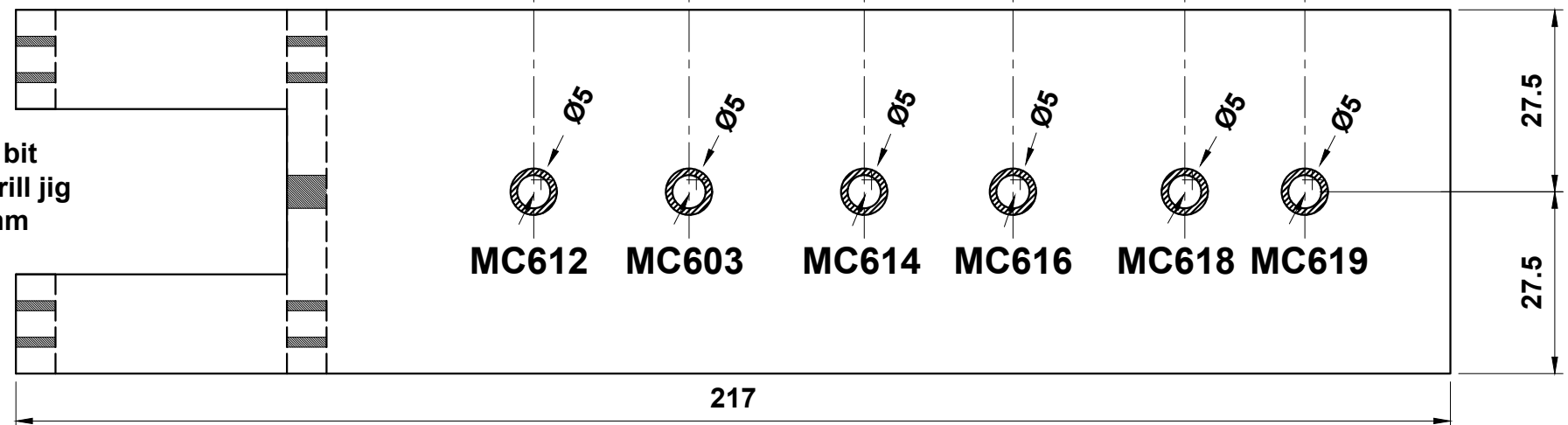
ACMC695 - Drill Jig



Align drill jig over centre line and clamp in position

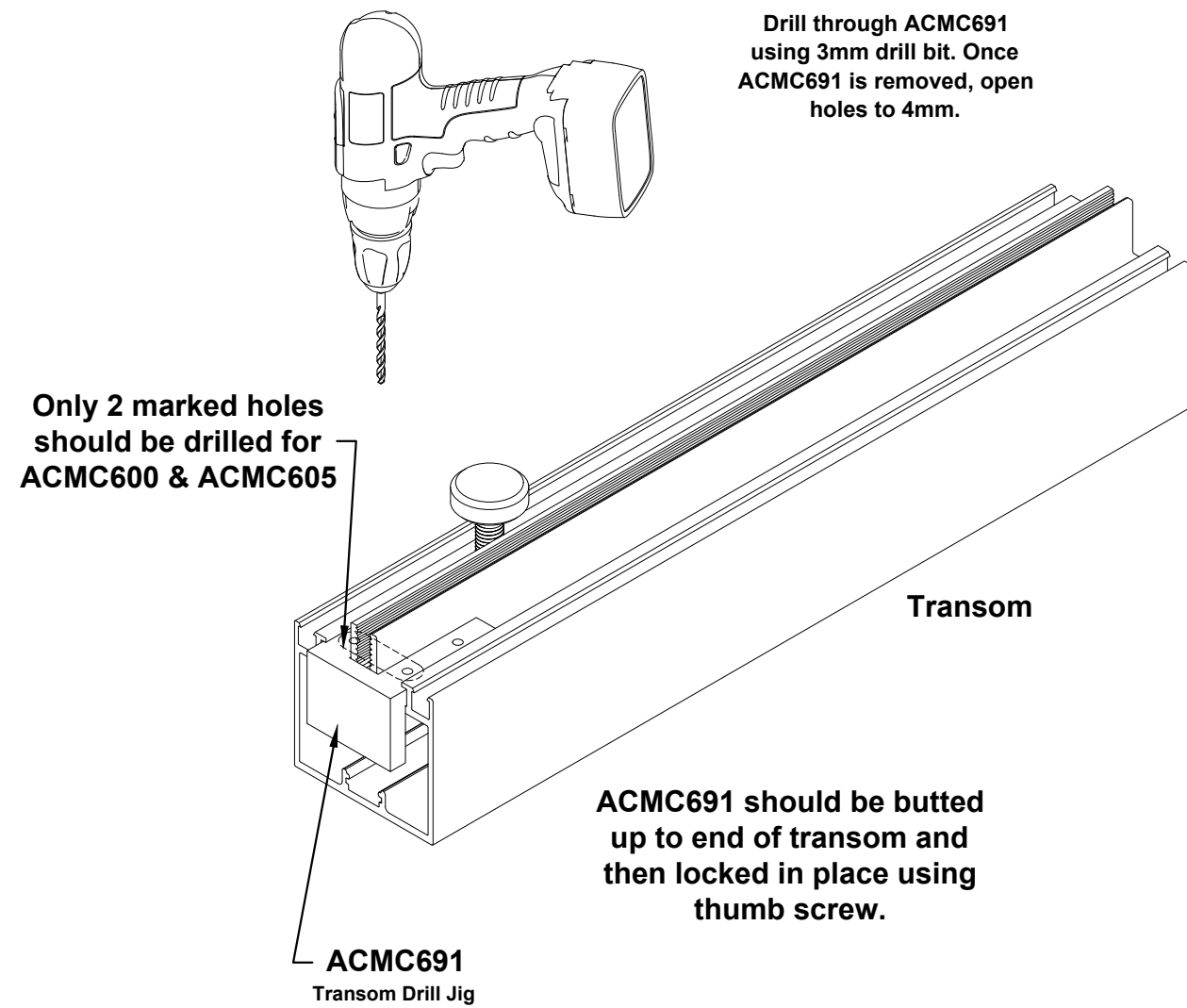


Drill with a Ø5mm bit using ACMC695 drill jig and open to Ø11mm

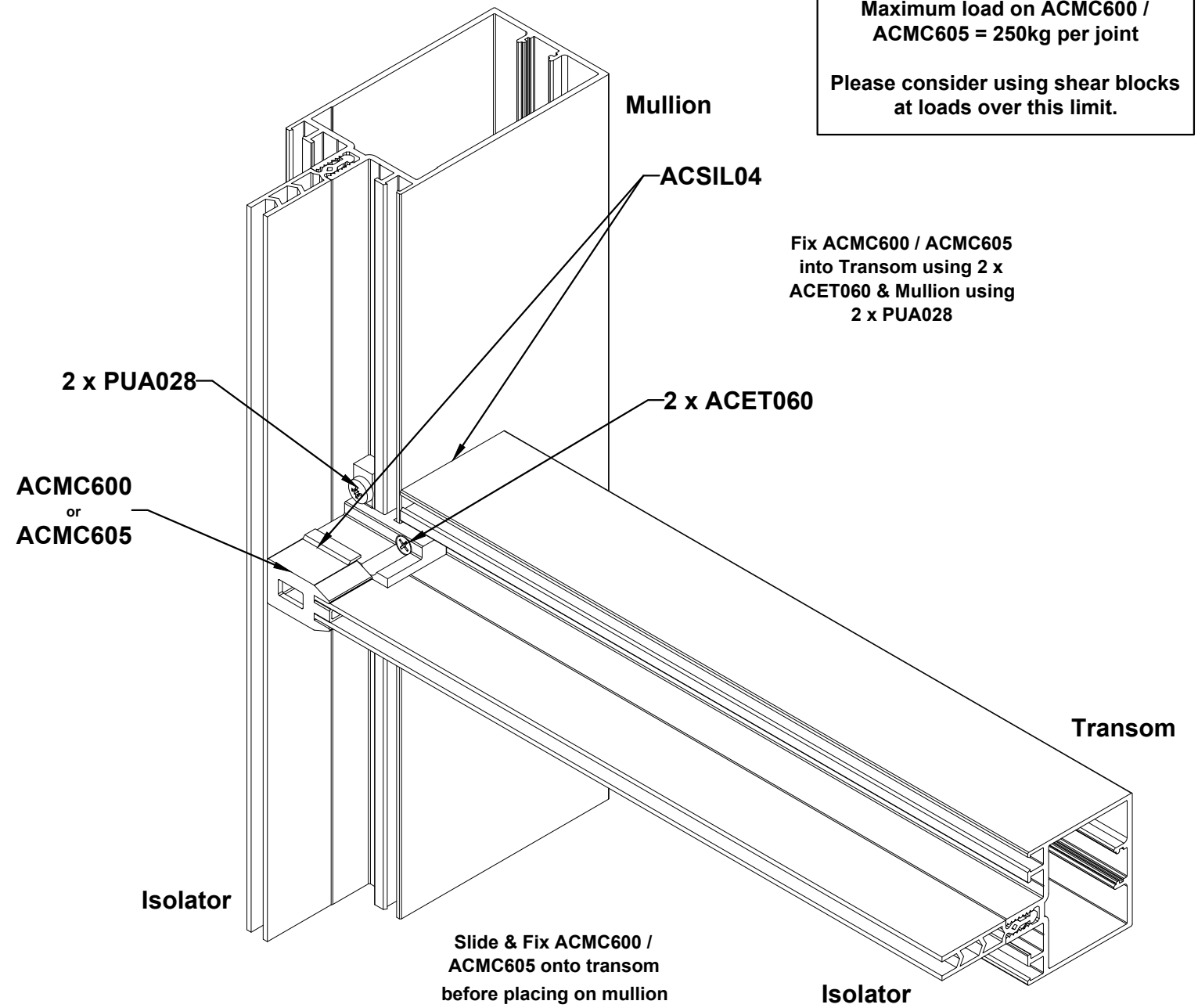


Do Not Scale From This Drawing

**Stick Build Transom Preparation**



Transom Brackets		
Transom Block	Isolator	Glazing Thickness
ACMC600	MC601	6mm - 32mm
ACMC605	MC602	34mm - 42mm

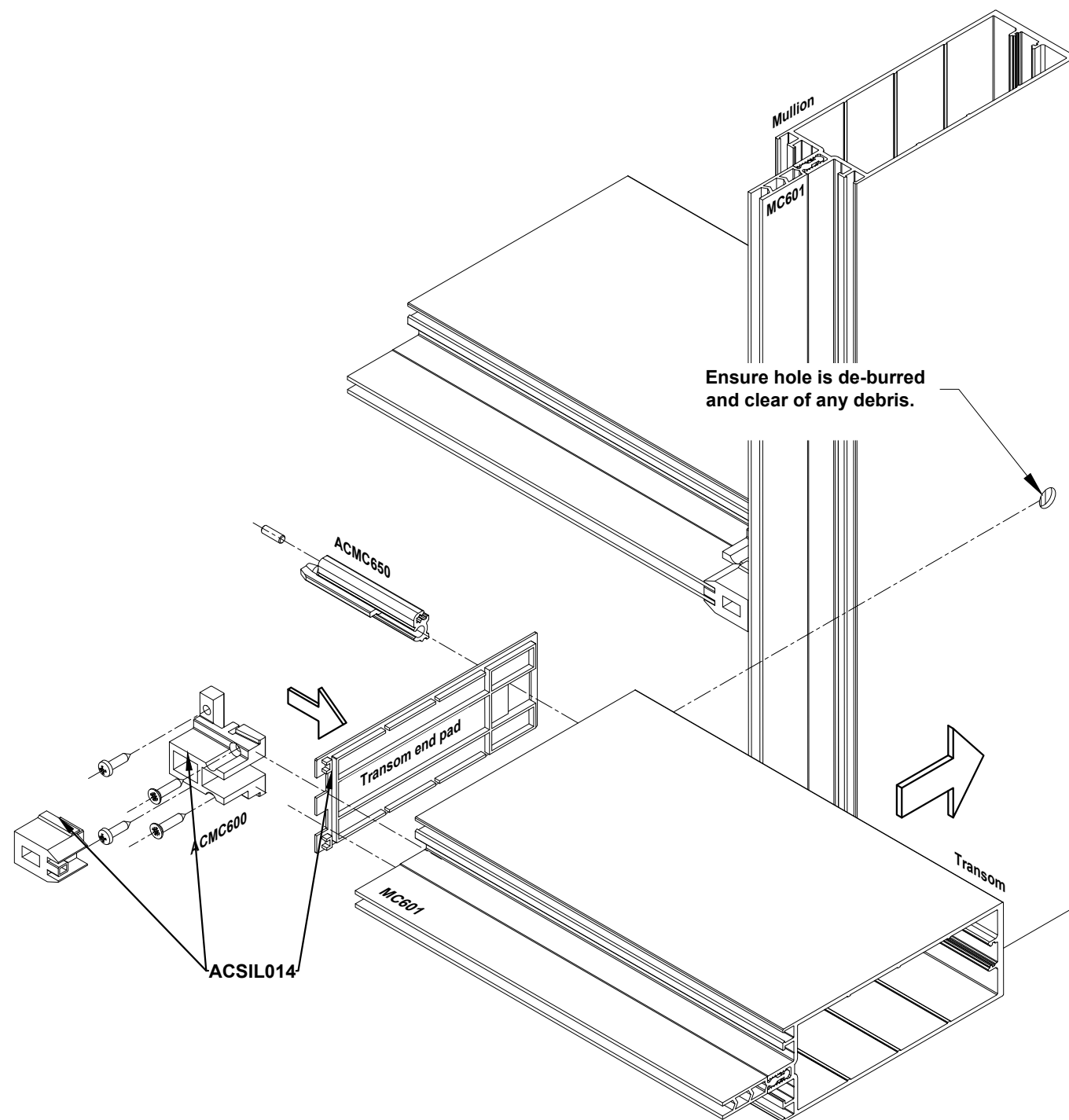


**IMPORTANT NOTE:**  
Maximum load on ACMC600 / ACMC605 = 250kg per joint  
Please consider using shear blocks at loads over this limit.

Fix ACMC600 / ACMC605 into Transom using 2 x ACET060 & Mullion using 2 x PUA028

Do Not Scale From This Drawing

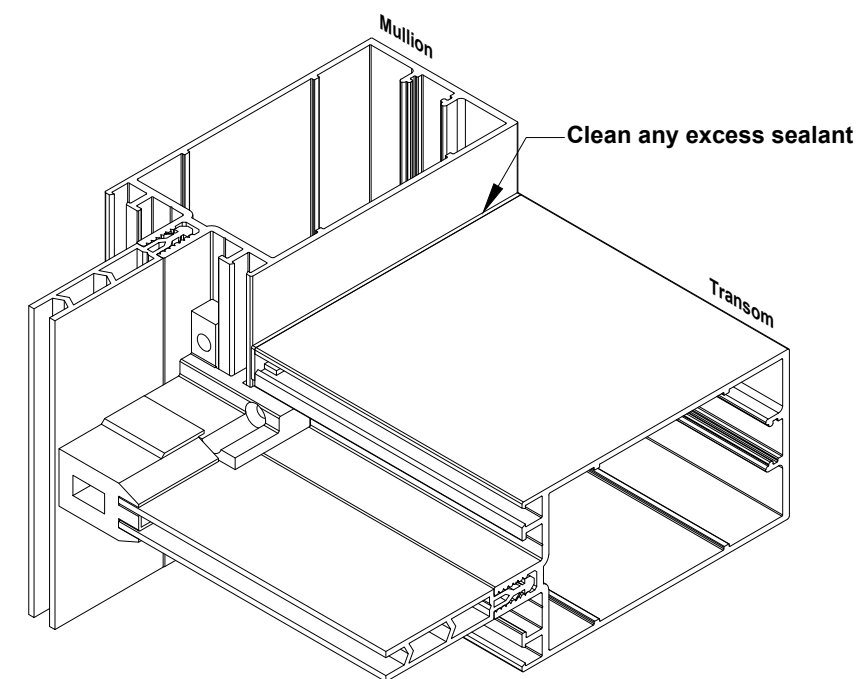
Stick Build Assembly - ACMC650 Spring Pin



SPRING PIN TO ENGAGE INTO HOLE IN MULLION

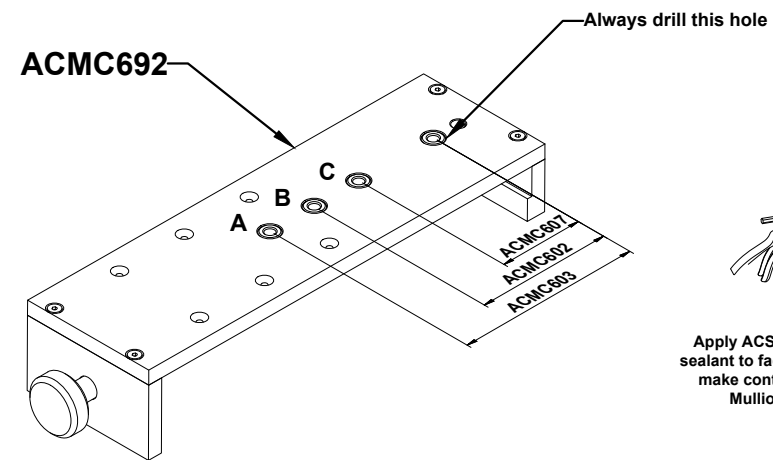
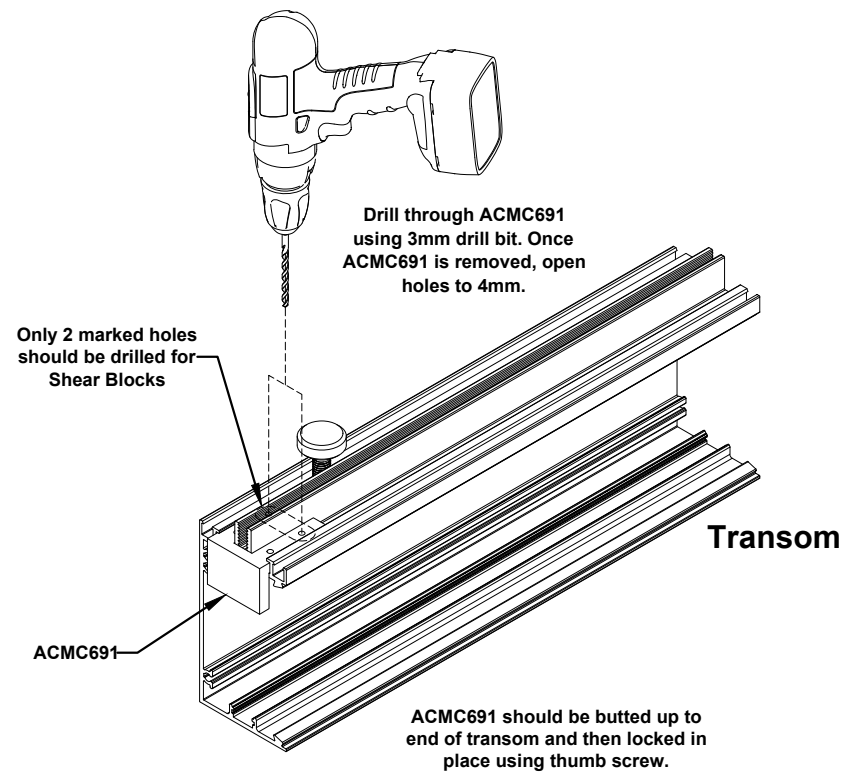
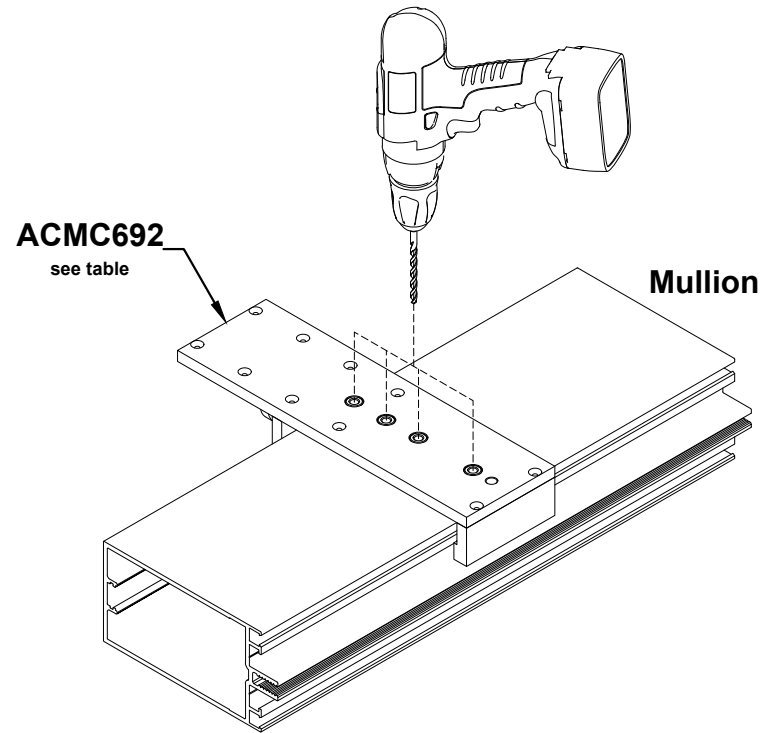
Apply ACSIL05 gasket rubber sealant to transom end pad close to the edges

Apply ACSIL05 gasket rubber sealant to transom bracket prior to fitting rubber cap

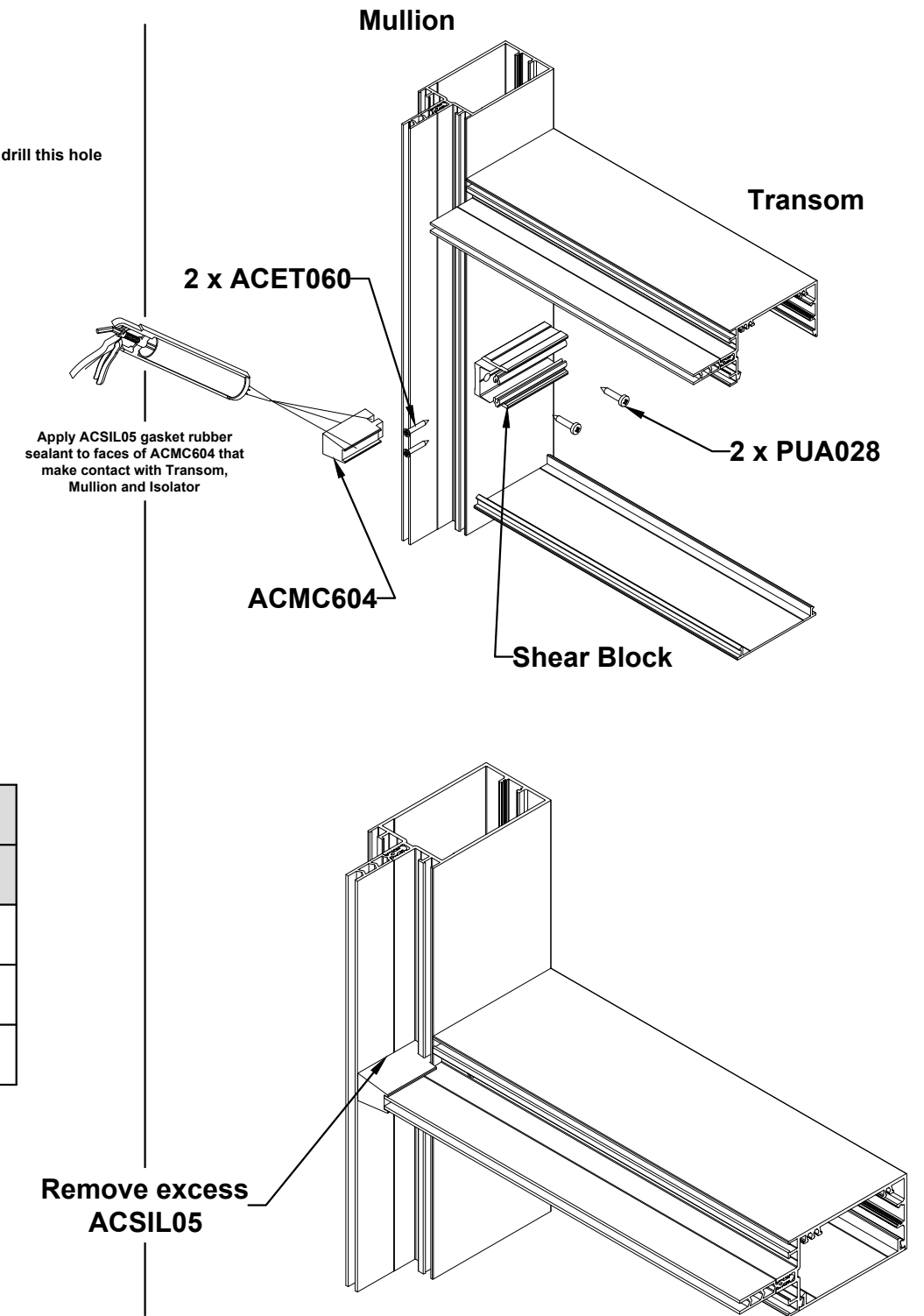


Do Not Scale From This Drawing

Ladder Build Assembly - Shear Blocks

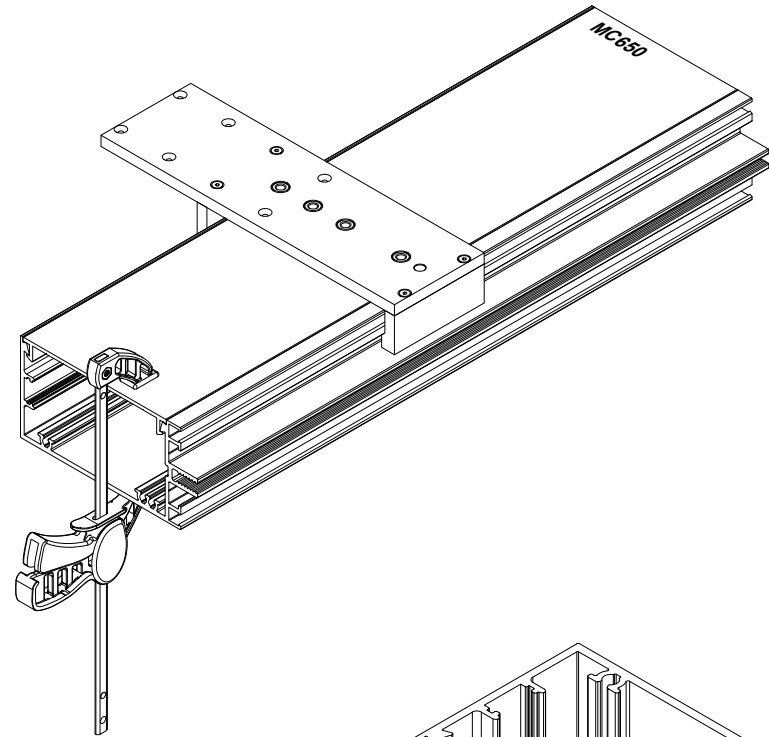


Ladder Frame Assembly		
Transom	Drill Location	Shear Block
MC604	C	ACMC602
MC614	B	ACMC603
MC617	A	ACMC607



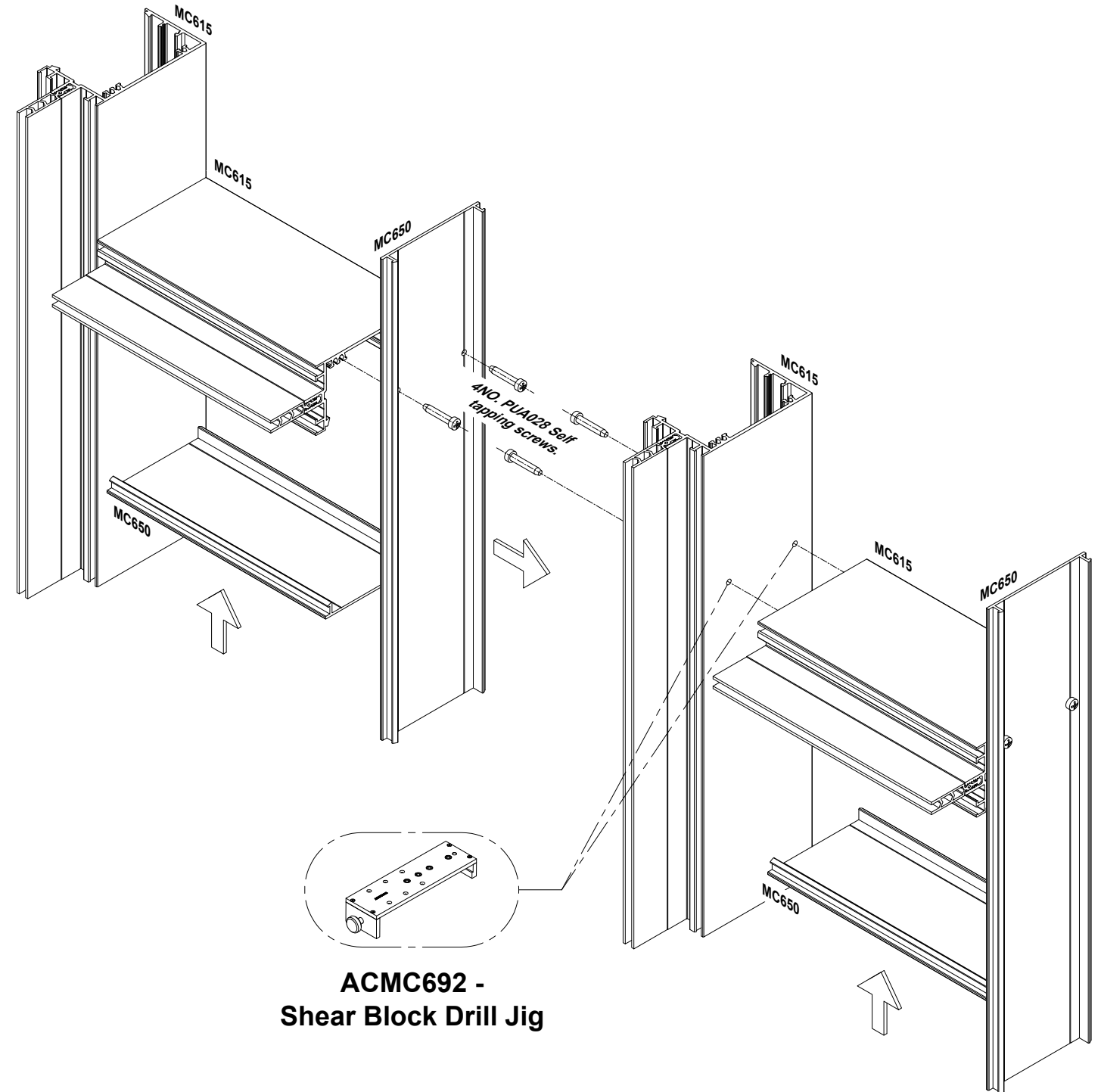
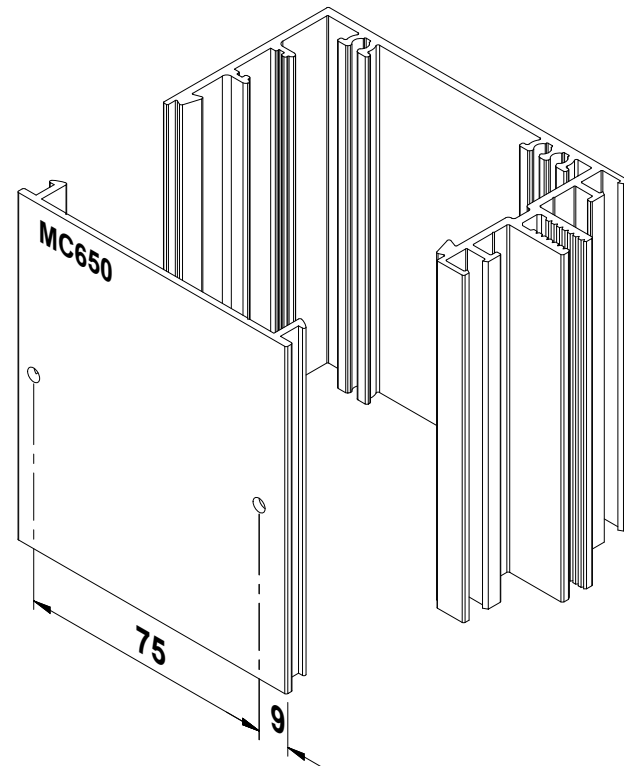
**Ladder Build Assembly - Shear Blocks**

For preparation of MC650/MC651, clamp profiles together and use ACMC692 drill jig.



or...

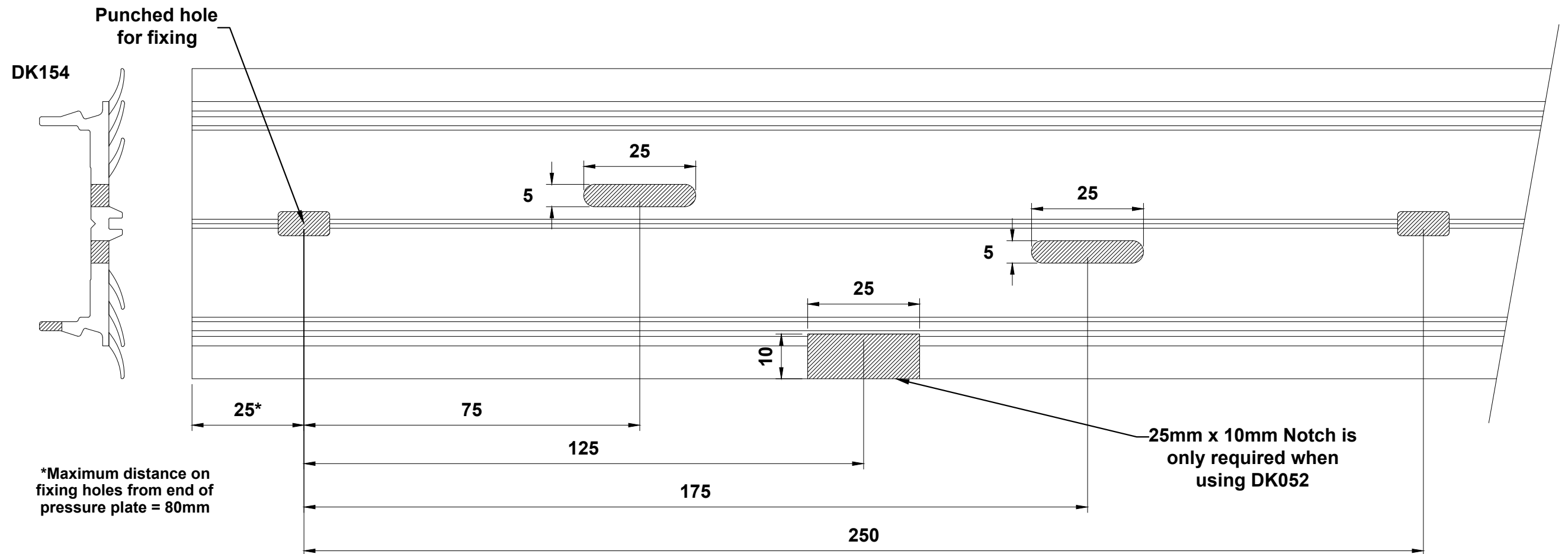
Machine back plate individually using dimensions shown.



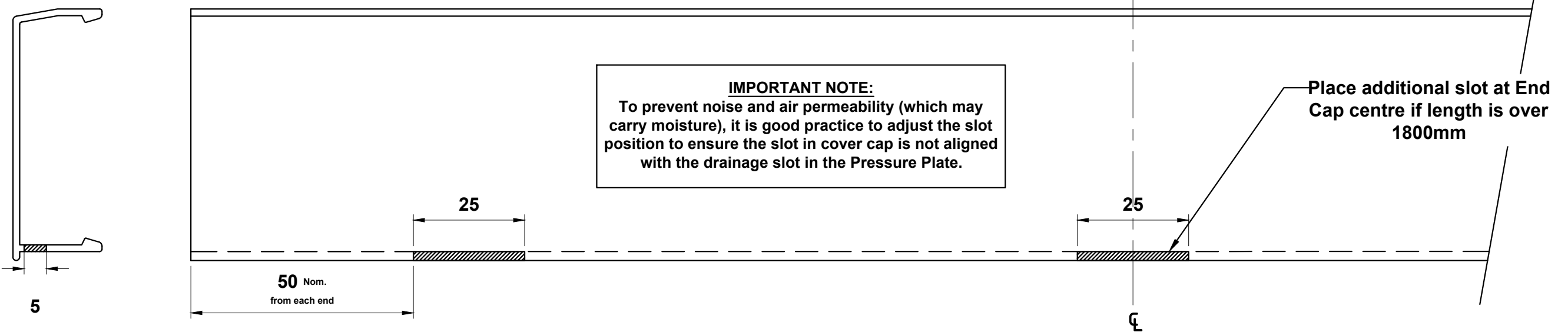
Do Not Scale From This Drawing



**Drainage & Pressure Equalisation**

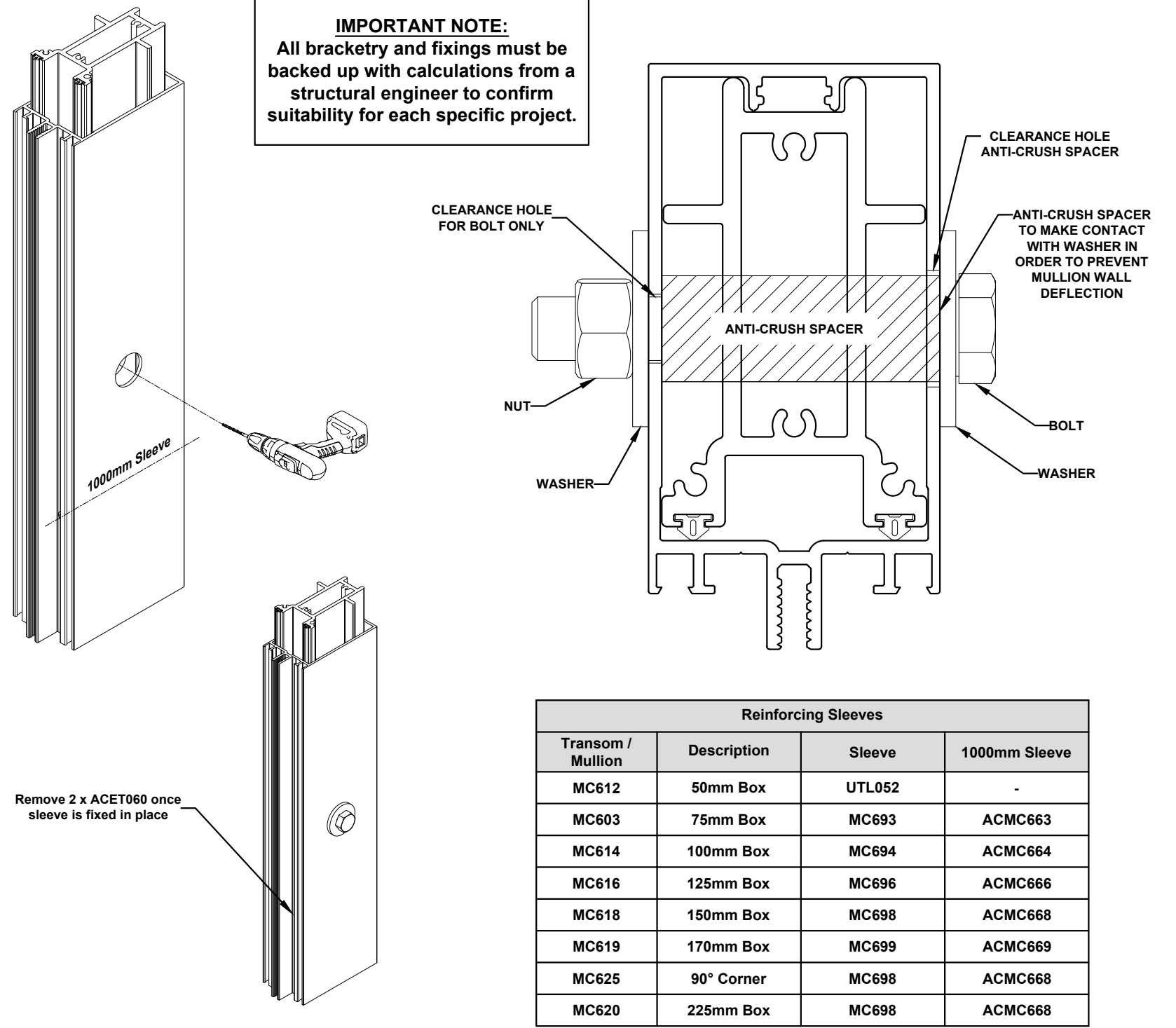
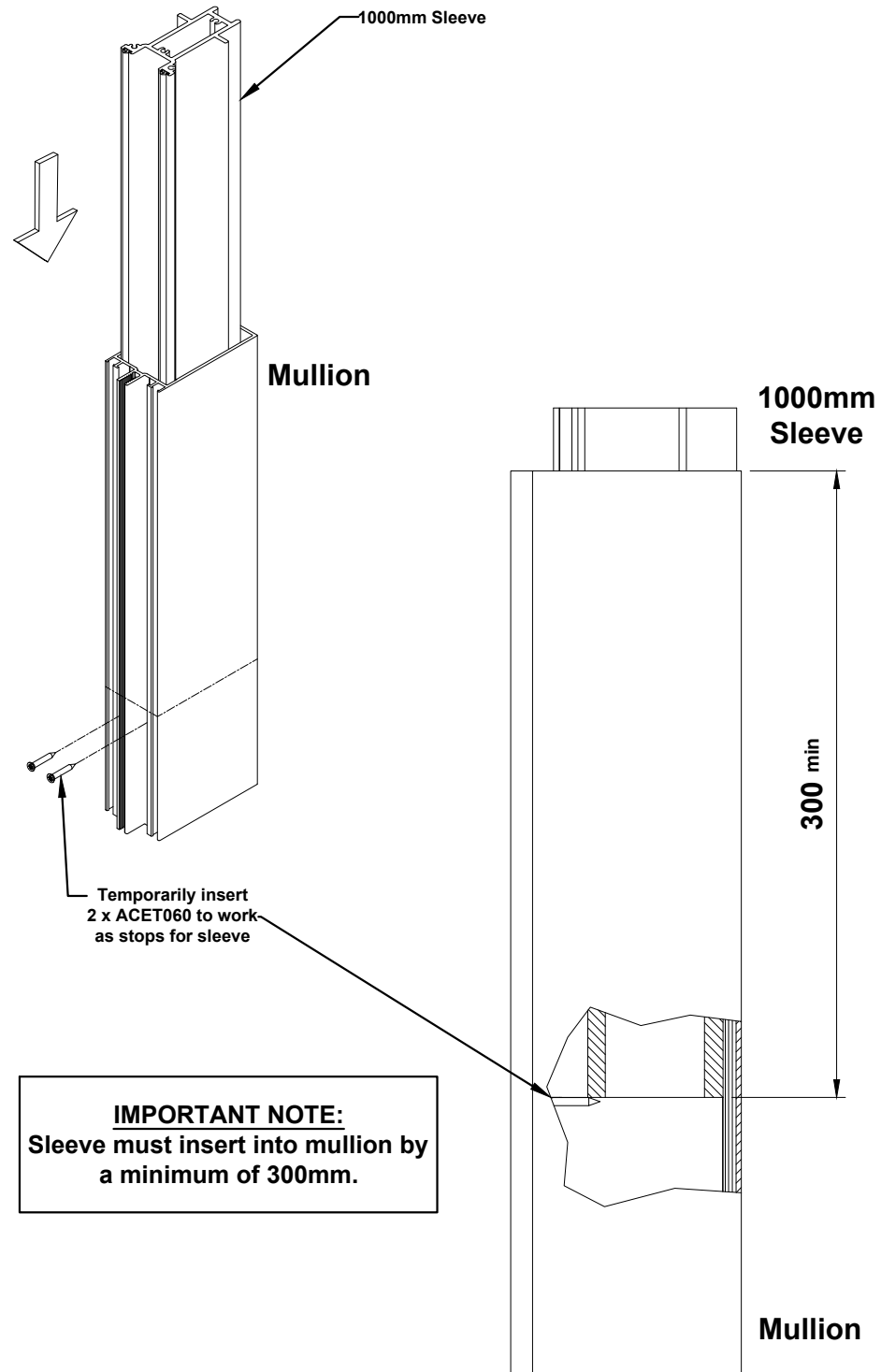


**MC652**



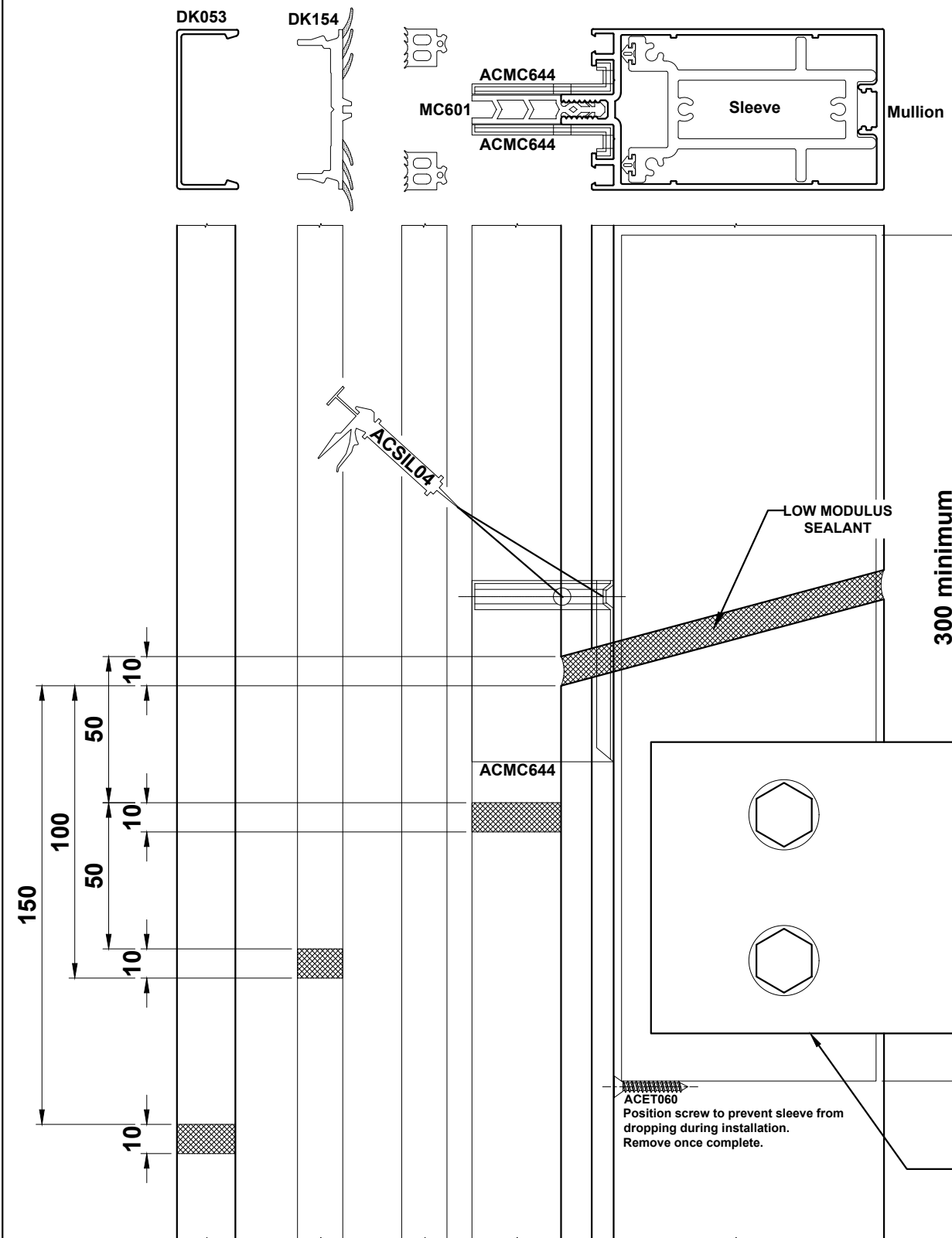
Do Not Scale From This Drawing

Reinforcing Sleeves



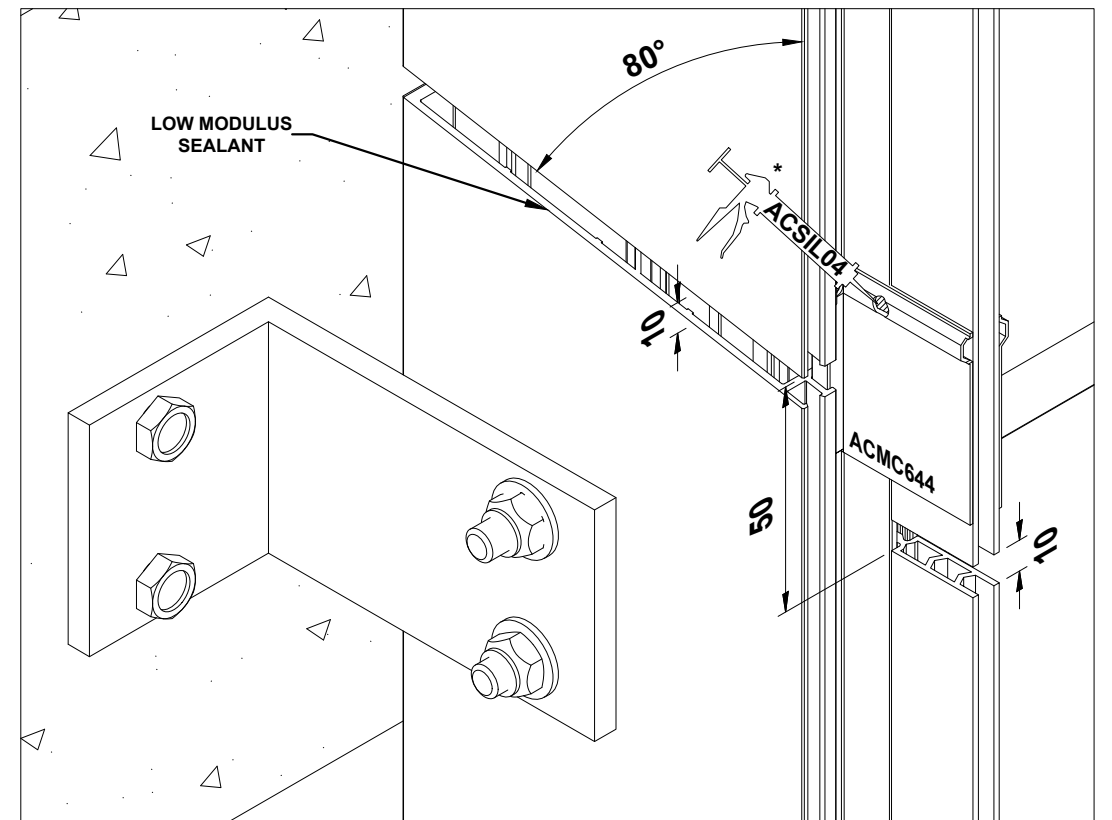
Do Not Scale From This Drawing

**Splice Joints**

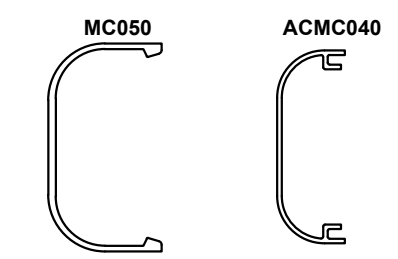


Bracket by others

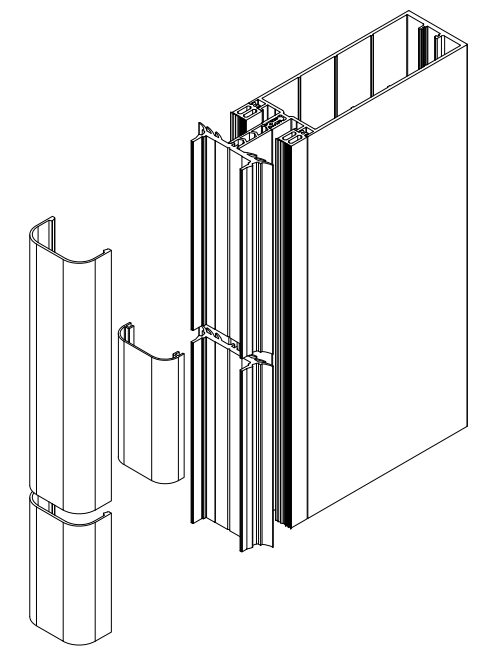
All brackets & fixings must be specified by a structural engineer



\* Ensure that glue holes on ACMC644 are above the splice joint.



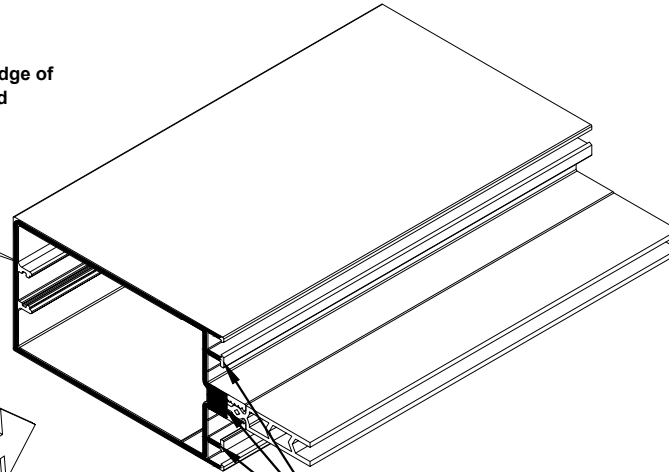
ACMC040 joint strap can be used with MC050 cap only



Do Not Scale From This Drawing

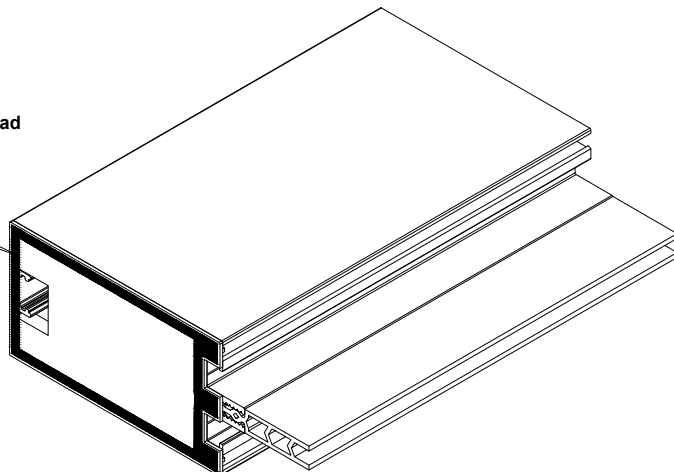
Transom / Mullion Sealing

ACSIL05 around perimeter of cut edge of transom before fitting end pad



Ensure to ACSIL05 end pad contact points

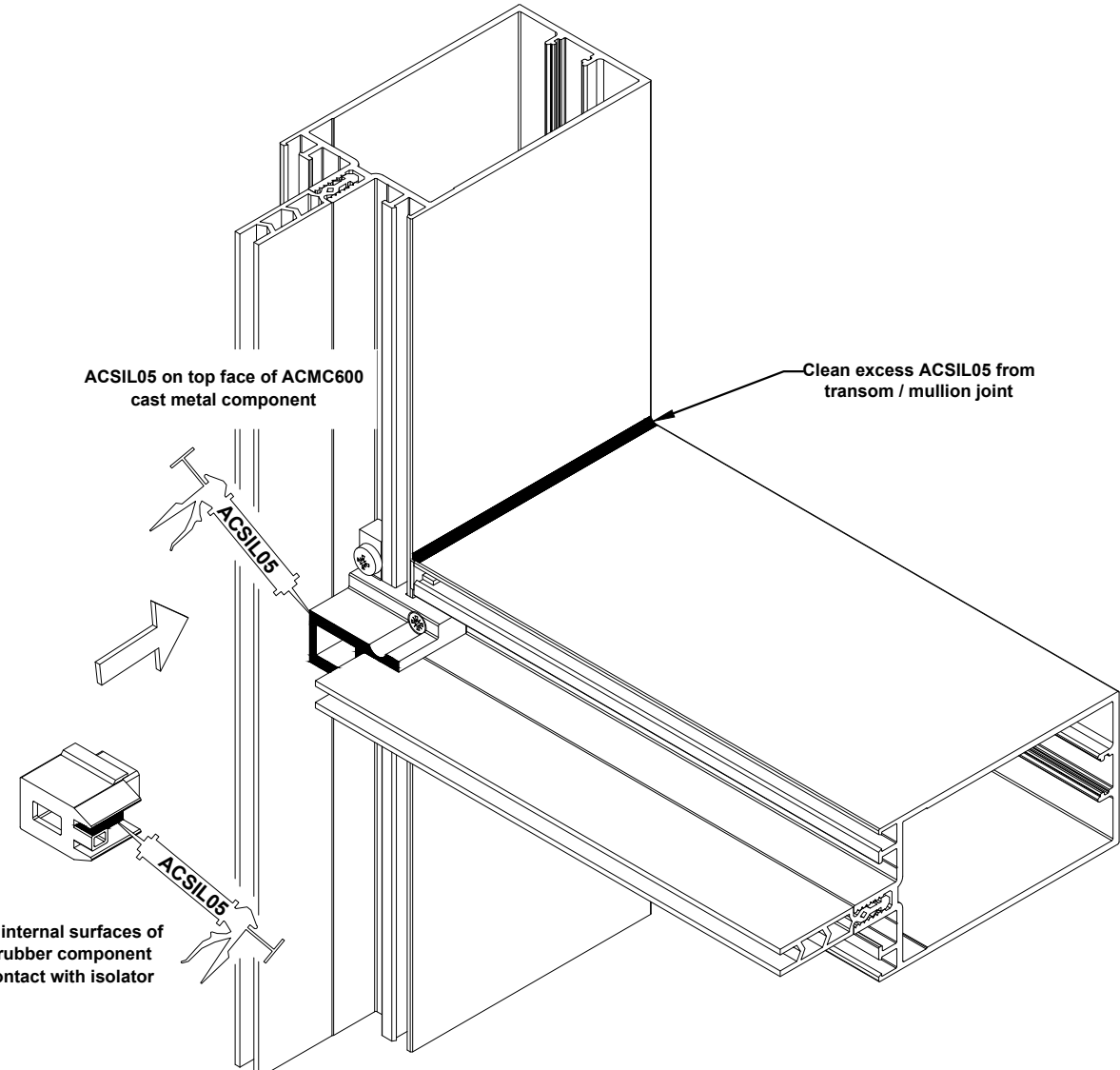
ACSIL05 around perimeter of end pad



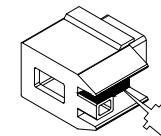
ACSIL05 on top face of ACMC600 cast metal component



Clean excess ACSIL05 from transom / mullion joint

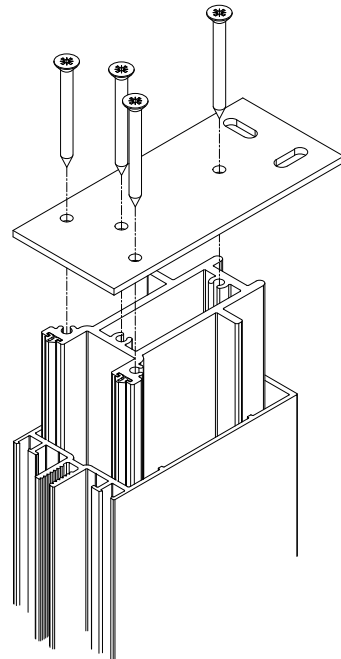
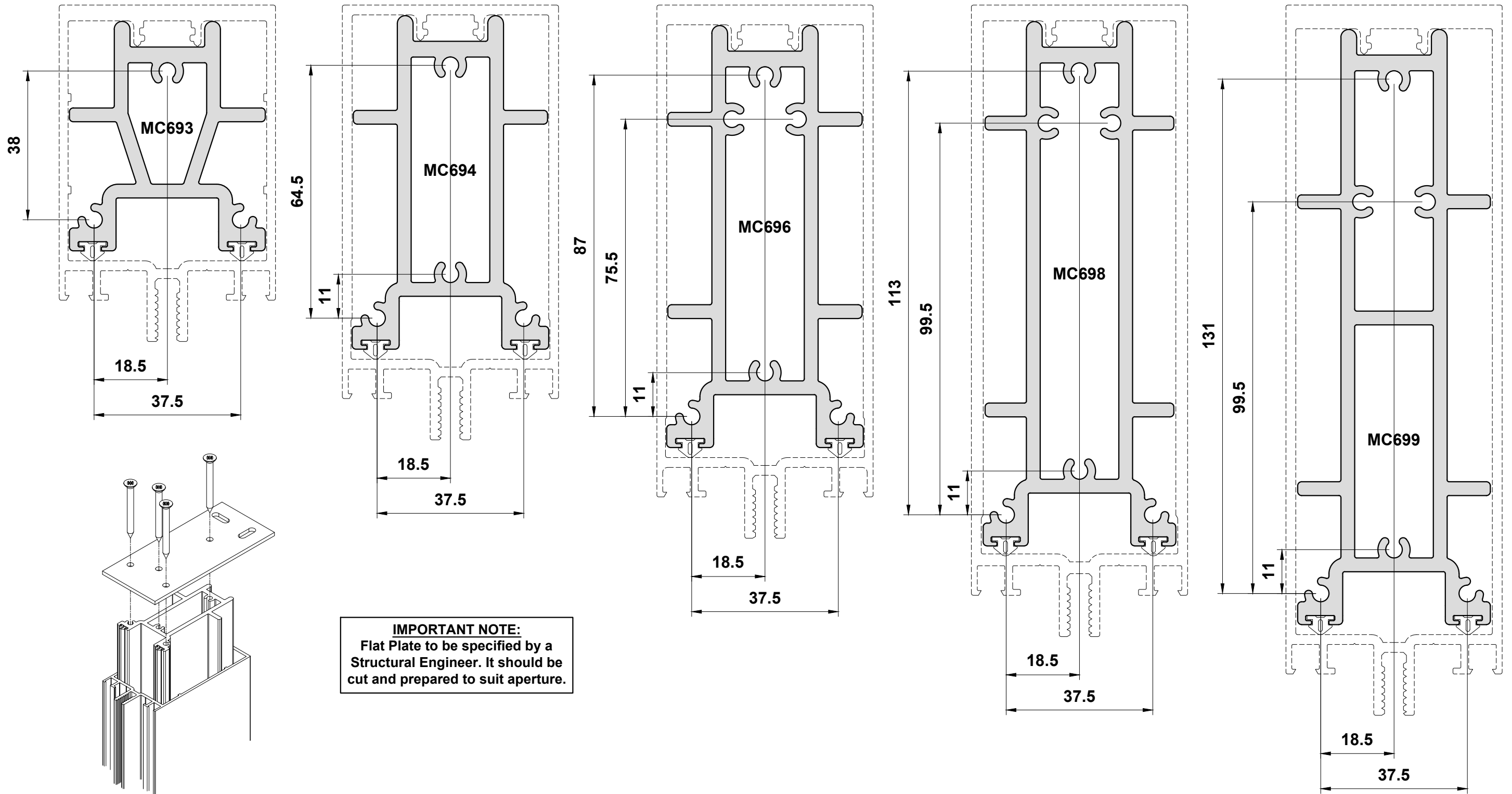


ACSIL05 on internal surfaces of ACMC600 rubber component where in contact with isolator



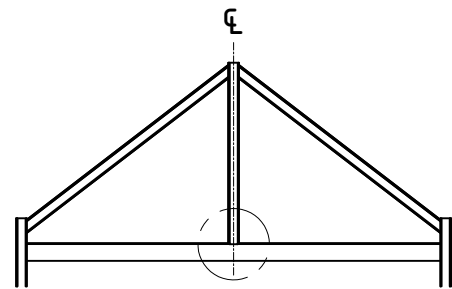
Do Not Scale From This Drawing

**Sleeves**

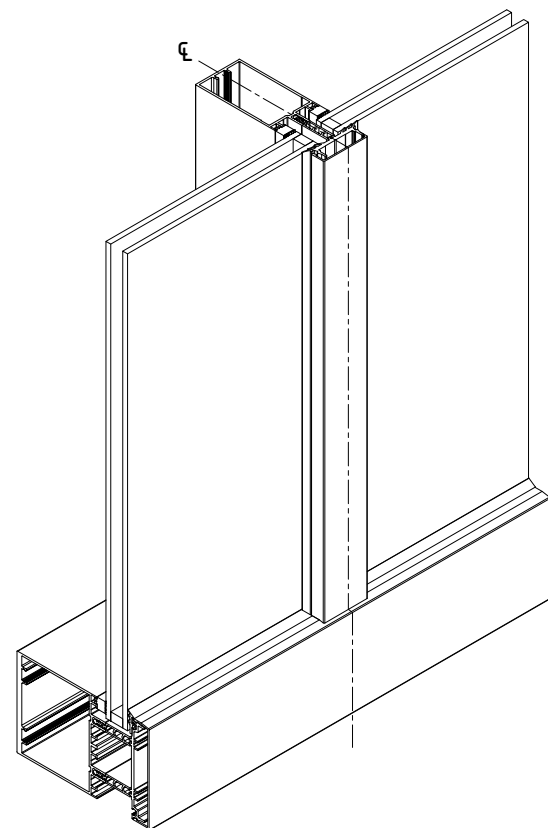


**Do Not Scale From This Drawing**

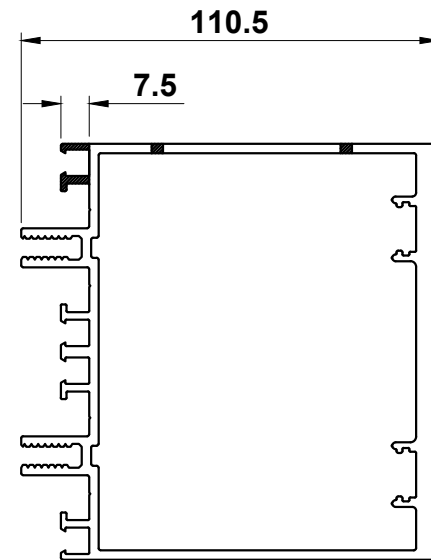
Mullion on Transom Preparation



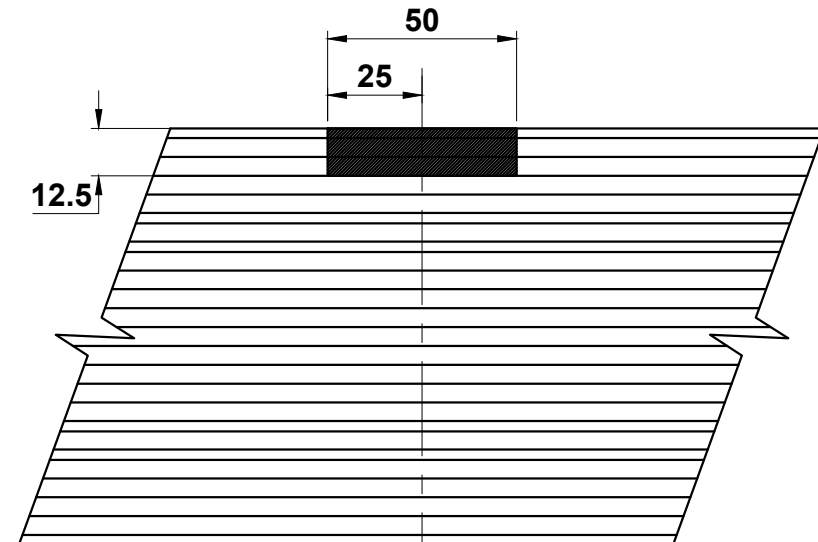
Gable end shown as example



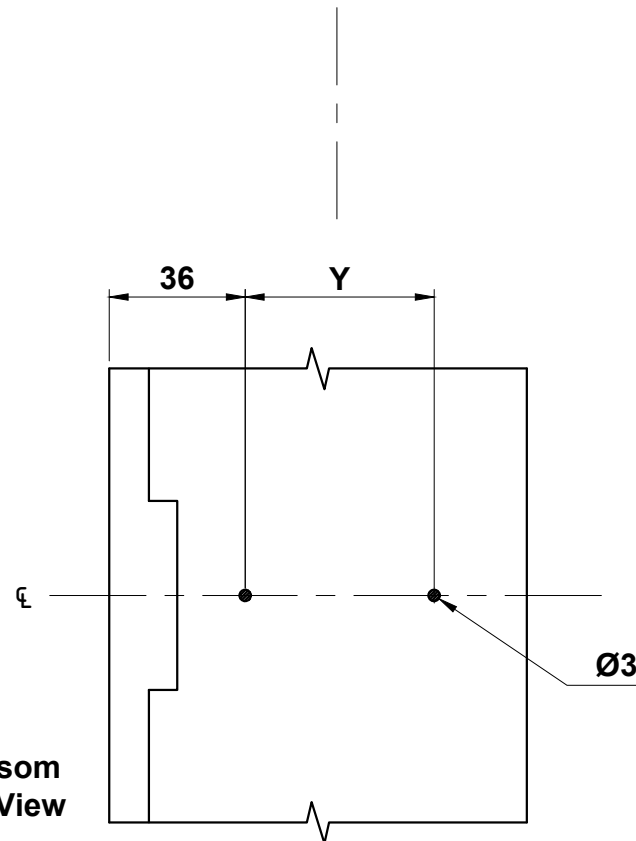
Transom  
END View



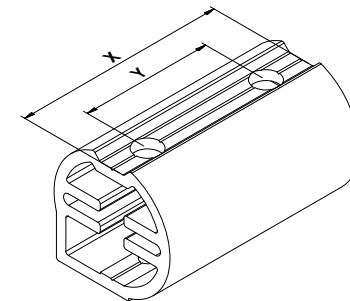
Transom  
FRONT View



Transom  
TOP View



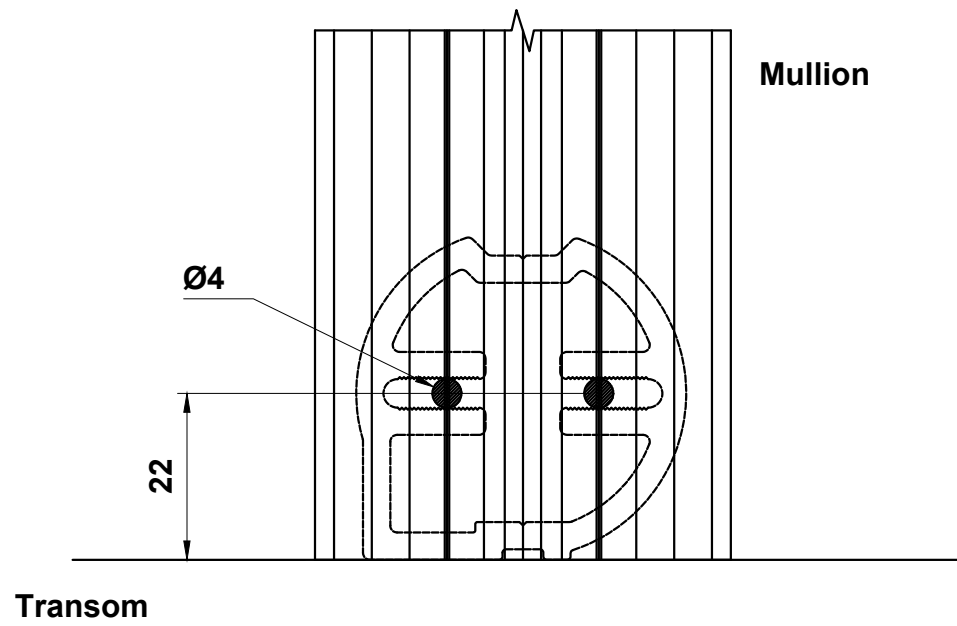
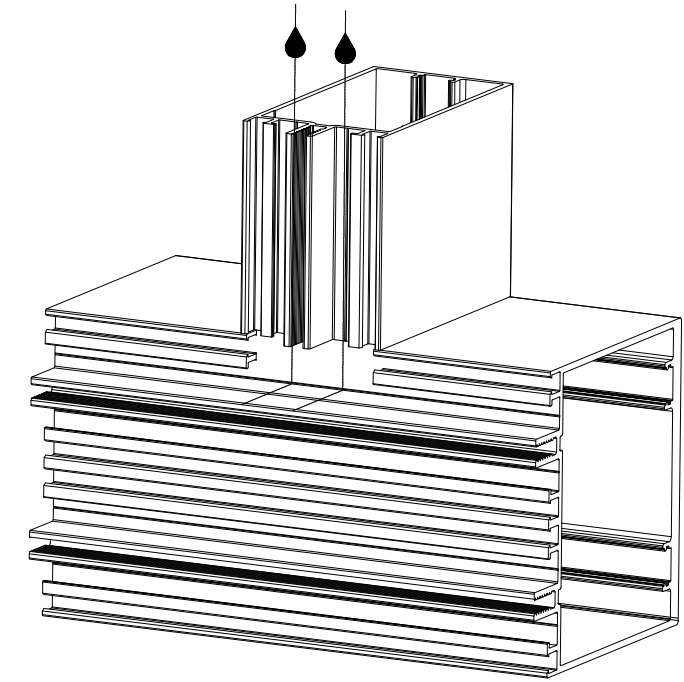
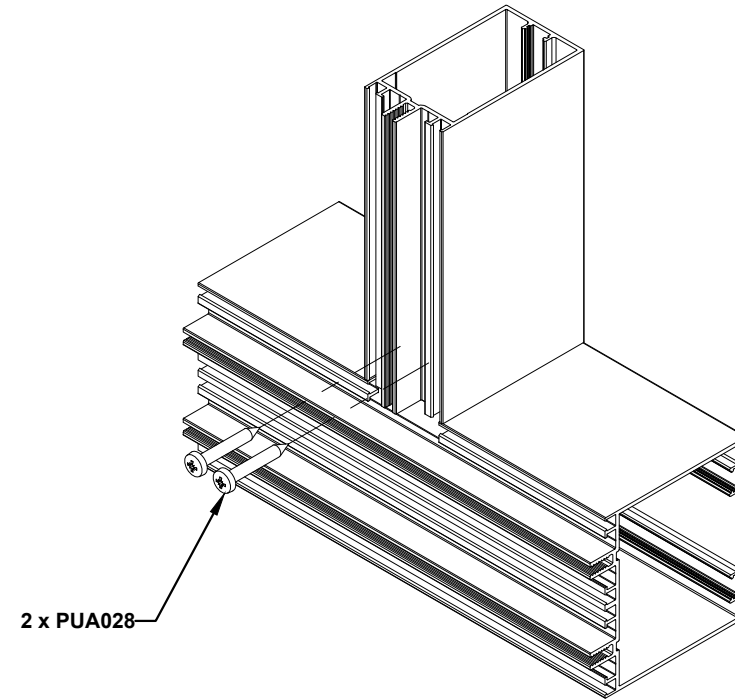
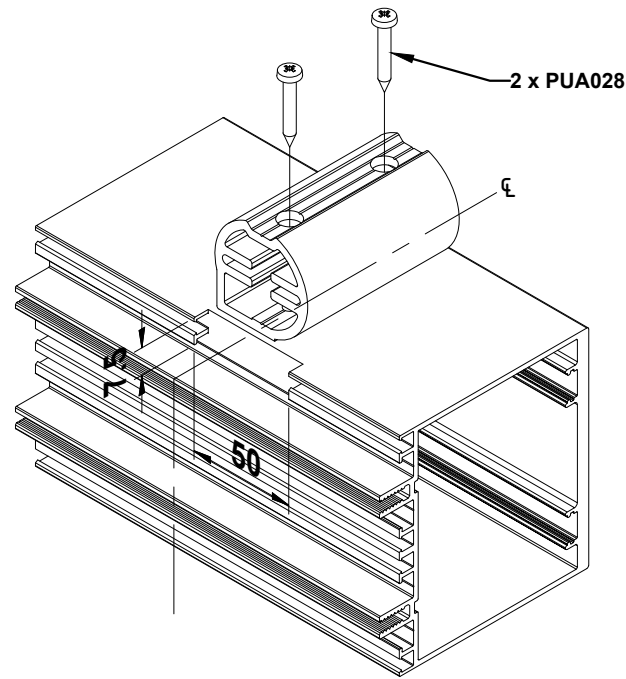
Shear Block	X (mm)	Y (mm)
ACMC6052	30	-
ACMC6053	53.5	23.5
ACMC6054	80	50
ACMC6056	102.5	72.5
ACMC6058	128	98
ACMC6059	146.5	116.5



		Transom						
		MC603	MC612	MC614	MC616	MC618	MC619	MC621
Mullion	MC603	ACMC6053		ACMC6053	ACMC6053	ACMC6053	ACMC6053	ACMC6053
	MC612	ACMC6052	ACMC6052	ACMC6052	ACMC6052	ACMC6052	ACMC6052	ACMC6052
	MC614			ACMC6054	ACMC6054	ACMC6054	ACMC6054	ACMC6054
	MC616				ACMC6056	ACMC6056	ACMC6056	
	MC618					ACMC6058	ACMC6058	
	MC619						ACMC6059	

Do Not Scale From This Drawing

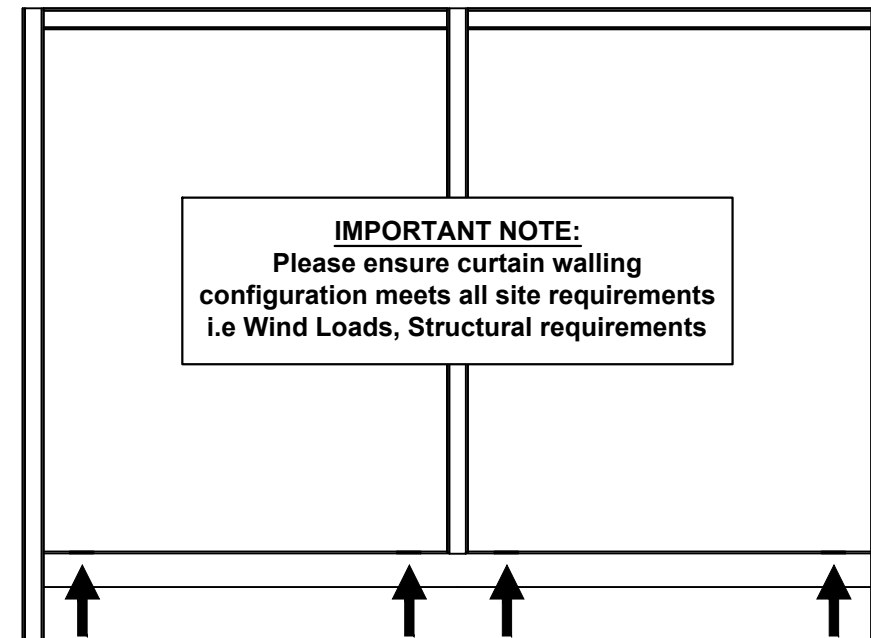
Mullion on Transom Assembly



Mullion

Transom

Consider packing location of Glass units.

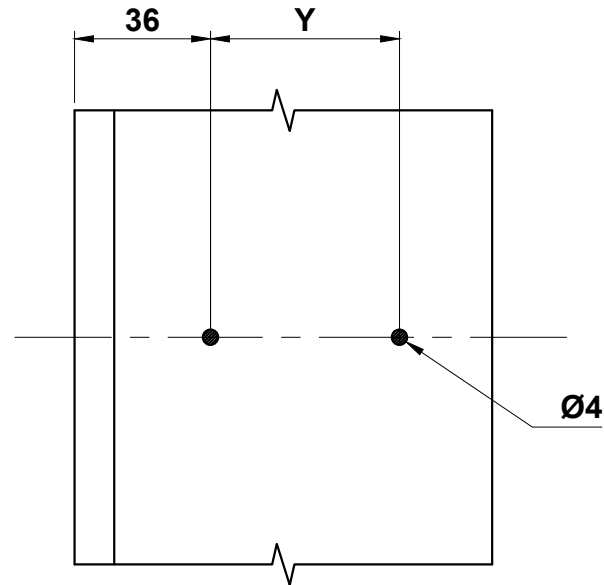
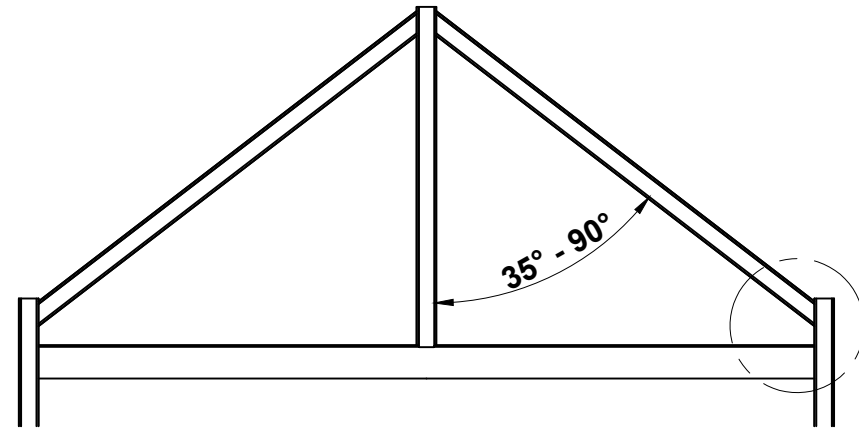


**IMPORTANT NOTE:**  
Please ensure curtain walling configuration meets all site requirements i.e Wind Loads, Structural requirements

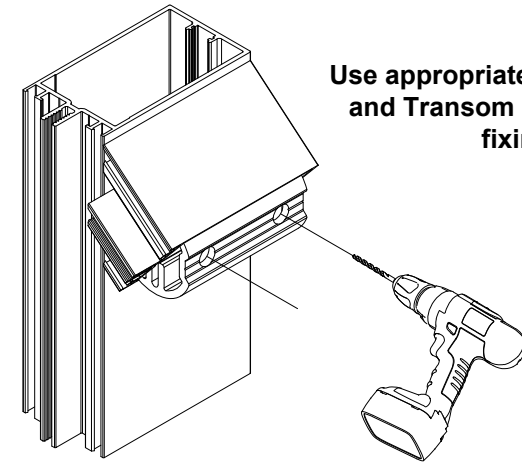
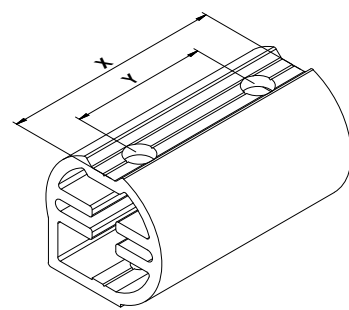
Consider fixing detail of mullion at head for support

Do Not Scale From This Drawing

**Raked Head**



Shear Block	X (mm)	Y (mm)
ACMC6052	30	-
ACMC6053	53.5	23.5
ACMC6054	80	50
ACMC6056	102.5	72.5
ACMC6058	128	98
ACMC6059	146.5	116.5

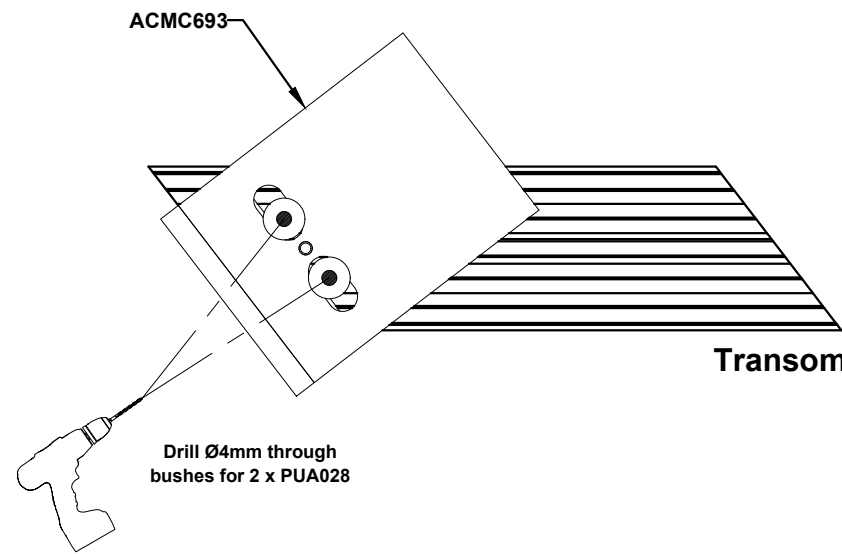


Use appropriate ACMC605\* Shear Block and Transom cut at desired angle for fixing locations.

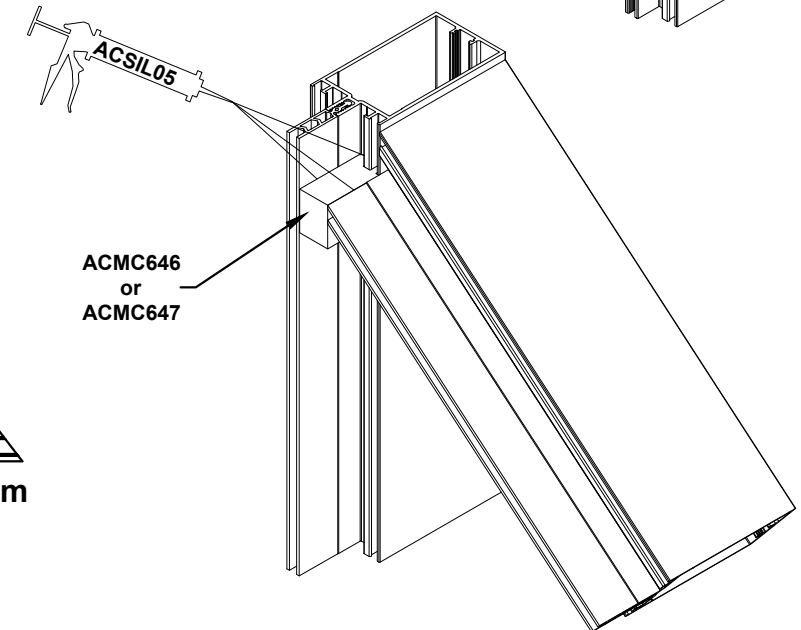
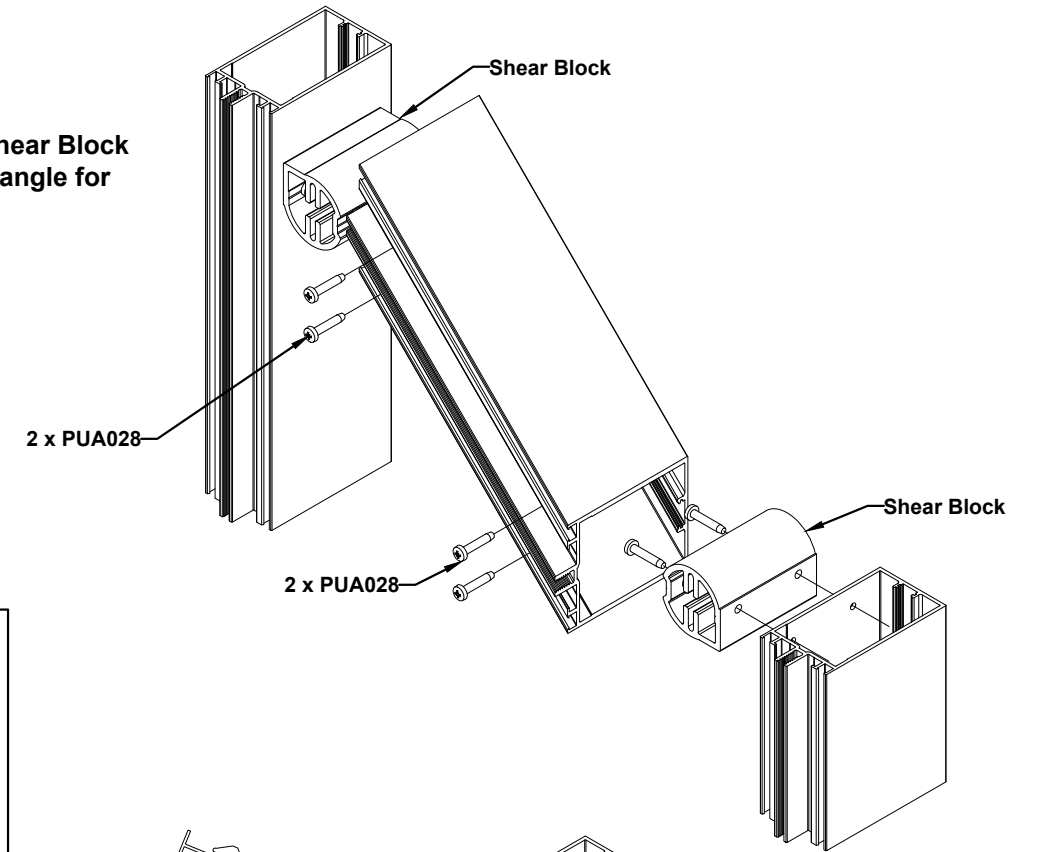
**PRE-DRILL MULLIONS IN FACTORY AND INSTALL SHEAR BLOCKS ON SITE.**

**IF SCREW LOCATIONS IN SHEAR BLOCK CLASH WITH REINFORCING SLEEVE, CONSIDER:**

- DRILLING NEW LOCATIONS IN SHEAR BLOCKS
- USING SHORTER SCREWS OR CUTTING SCREWS DOWN
- DRILLING HOLES IN REINFORCING SLEEVE



Drill Ø4mm through bushes for 2 x PUA028



ACMC646 or ACMC647

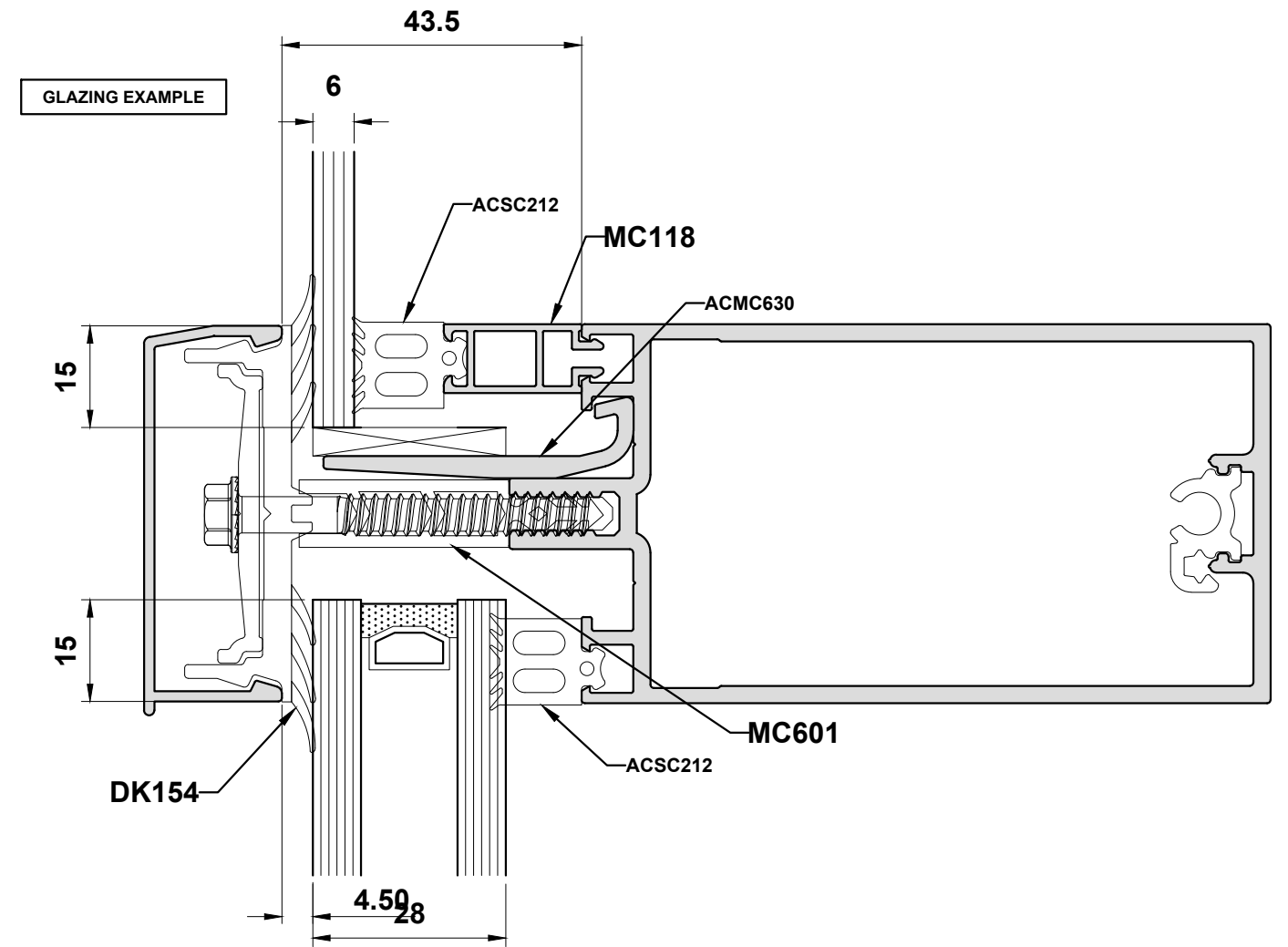
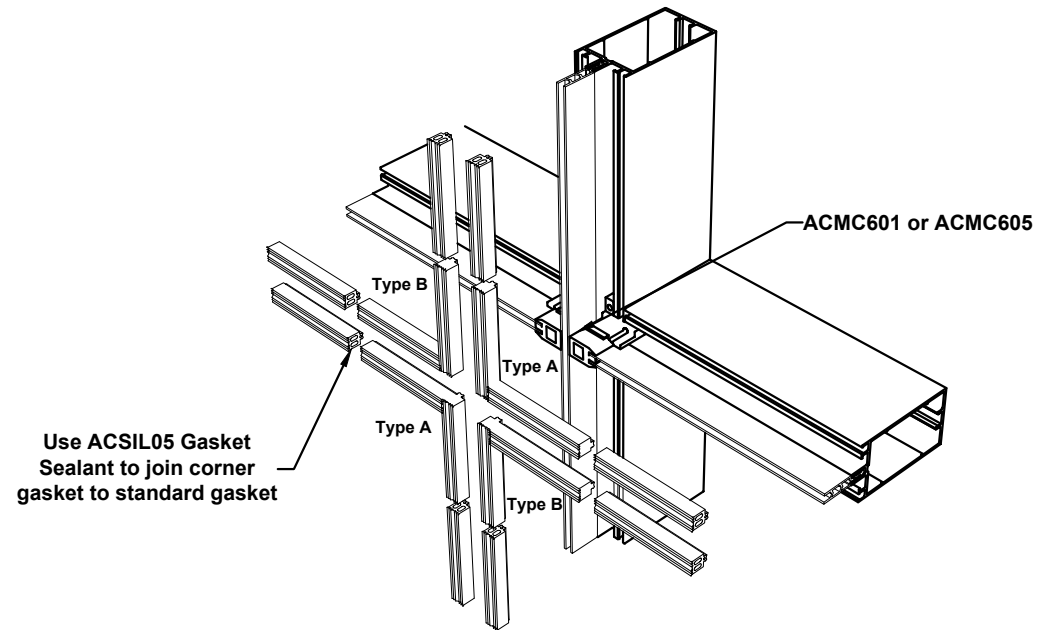
**Do Not Scale From This Drawing**



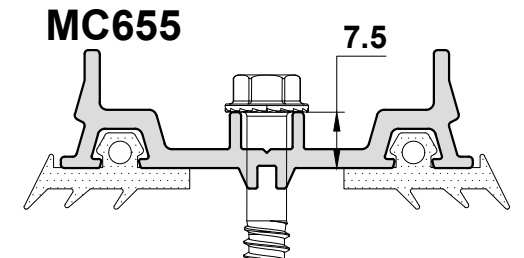
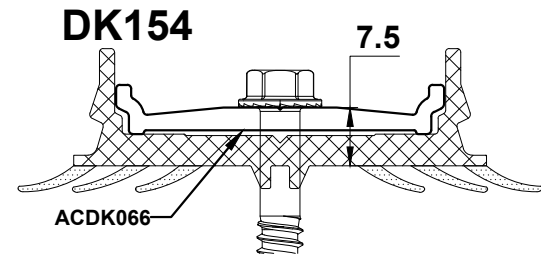
Glazing Details

	Internal Gasket	Corner Gasket	Glazing Support	Isolator	Screw	Transom Bracket
6**	ACSC212	ACMC624	ACMC630	MC601	ACMC610	ACMC600
10**	ACSC208	ACMC632	ACMC630	MC601	ACMC610	ACMC600
14*	ACMC115	ACMC624	ACMC630	MC601	ACMC610	ACMC600
24	ACMC115	ACMC624	ACMC630	MC601	ACMC610	ACMC600
28	ACSC212	ACMC628	ACMC630	MC601	ACMC610	ACMC600
32	ACSC208	ACMC632	ACMC630	MC601	ACMC610	ACMC600
34	ACMC115	ACMC624	ACMC631	MC602	ACMC612	ACMC605
38	ACSC212	ACMC628	ACMC631	MC602	ACMC612	ACMC605
42	ACSC208	ACMC632	ACMC631	MC602	ACMC612	ACMC605

\*1 x MC116 required  
\*\*1 x MC118 required



**IMPORTANT NOTE:**  
ACDK066 is to be used with DK154 only



THIS PAGE IS INTENTIONALLY LEFT BLANK

Do Not Scale From This Drawing